

# K450

## v.03

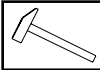
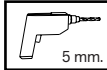

A x 06	B x 06	C x 48	D x 08	E x 08	F x 30	G x 83	H x 08	I x 08
J x 09	K x 11	L x 02	M x 04	N x 36	Ñ x 16	O x 10	P x 04	Q x 06
R x 02	S x 08	T x 06	U x 04	V x 08	W x 08	Y x 08	Z x 14	AB x 02
AC x 03	AD x 01	AE x 01	AF x 24	AG x 08	AH x 20	AI x 06		

## Option A

## Option B

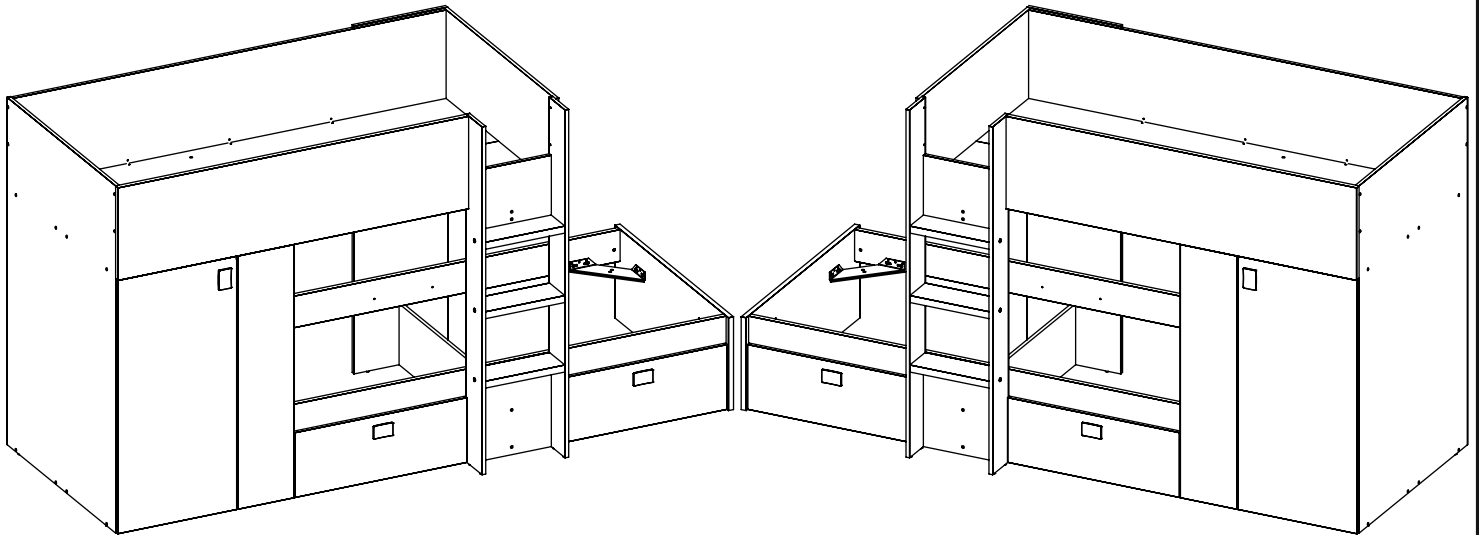

### ES

#### RECOMENDACIONES MONTAJE Y USO

Agrupe y cuente el herraje.  
 Prepare todas las piezas para el montaje del mueble.  
 Tenga preparadas las herramientas para el montaje.  
 Prepare la zona del montaje.  
 Monte el mueble sobre una moqueta para evitar rayar y dañar la superficie del mueble.  
 No fuerce los ensamblajes.  
 Evite colocar el mueble cerca de fuentes de calor.  
 Evite utilizar trapos, paños o productos de limpieza que puedan dañar la superficie del mueble.  
 Mueble para uso doméstico en interior de vivienda.

### EN

#### RECOMMENDATIONS FOR ASSEMBLY AND USE

Prepare all the parts of the furniture  
 Group and count all the hardware  
 Prepare all the tools for the assembly.  
 Clear and prepare the assembly area.  
 Do the assembly on a carpet to avoid damaging the surface of the furniture  
 Avoid forcing the fittings  
 Avoid placing the Furniture near any heating source  
 Do not use cloths or cleaning products to avoid damaging the surface of the furniture  
 Indoor furniture. Suitable for domestic use.

### FR

#### CONSEILS DE MONTAGE CONSEILS POUR L'USAGE

Préparez les différents parts du meuble  
 Regrouper et compter toute la quincaillerie  
 Préparez l'outillage nécessaire  
 Aménagez-vous une area de montage  
 Faire le montage sur moquette afin de protéger le meuble des rayures  
 Ne forcer pas le montage  
 Évitez placer le meuble près des sources de chaleur  
 Évitez utiliser de chiffons ou des produits de nettoyage pour ne pas rayser la superficie du meuble  
 Meuble d'usage domestique pour l'intérieur de la maison.

### PT

#### RECOMENDAÇÕES PARA MONTAGEM E USO

Prepare todas as peças para a montagem de móveis  
 Reagrupar e contar o hardware  
 Preparar as ferramentas de montagem  
 Preparar a área de montagem  
 Montar as peças sobre tapete para evitar riscos e danos na superfície dos móveis  
 Não force as assembleias  
 Não colocar móveis perto de fontes de calor  
 Evitar o uso de panos, trapos ou produtos de limpeza que possam riscar o móvel.  
 Móveis para uso doméstico no interior da casa.

### IT

#### CONSIGLI INSTALLAZIONE ED USO

Preparare tutti componenti del mobile per il montaggio  
 Ordinate la ferramenta  
 Preparare tutti gli attrezzi necessari per il montaggio  
 Preparare l'area di montaggio  
 Fare il montaggio su un tappeto per evitare danneggiare le superfici dei mobili  
 Non forzare i componenti  
 Evitare posizionare il mobile in prossimità di fonti di calore  
 Non usare panni né detersivi né solventi che possano danneggiare le superficie dei mobili  
 Mobili per uso domestico all'interno della casa.

### DE

#### MONTAGEHINWEISE-GEBRUCHSHINWEISE

Identifizieren Sie die Einzelteile  
 Überprüfen Sie Die Anzahl der einzelnen Beschlagteile  
 Legen Sie das notwendige Werkzeug bereit  
 Bereiten die Montagefläche  
 Montieren Sie das Möbel auf einem Teppich , sauberen Untergrund  
 Niemals die Verbindungen zu stark anziehen  
 Nicht neben Wärmequellen platzieren  
 Vermeiden Sie Tücher und keinesfalls scharfe oder ätzende Reinigungsmittel.  
 Möbel für den Gebrauch im Haus geeignet.

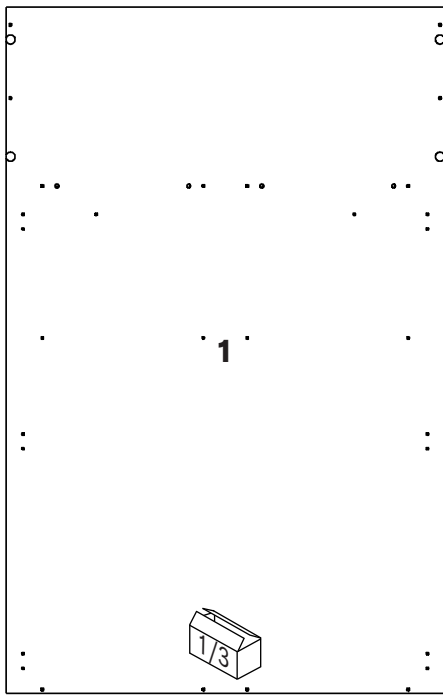

958 x 1500 mm.

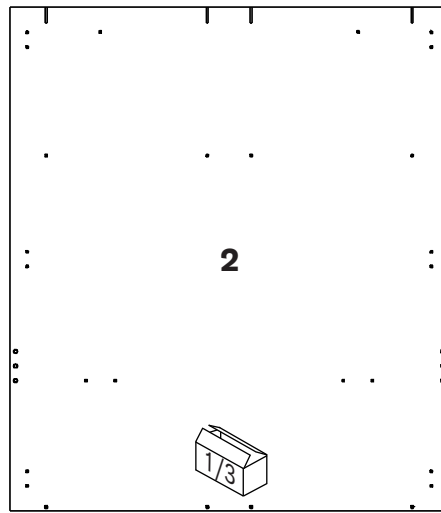

958 x 1101 mm.

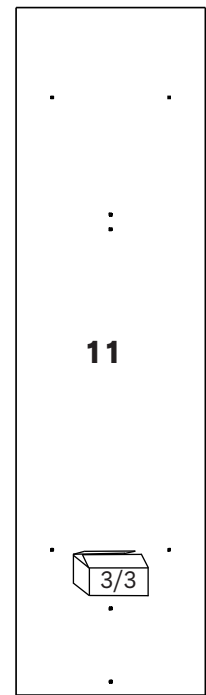

414 x 1502 mm.

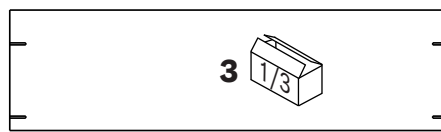

959 x 263 mm.

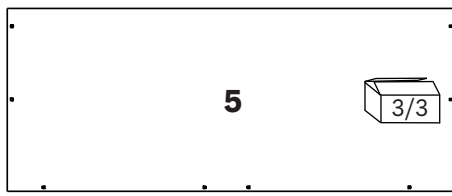

978 x 400 mm.

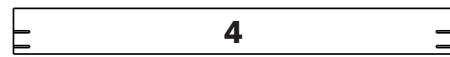

959 x 100 mm.

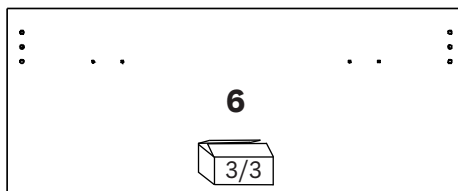

1000 x 401 mm.

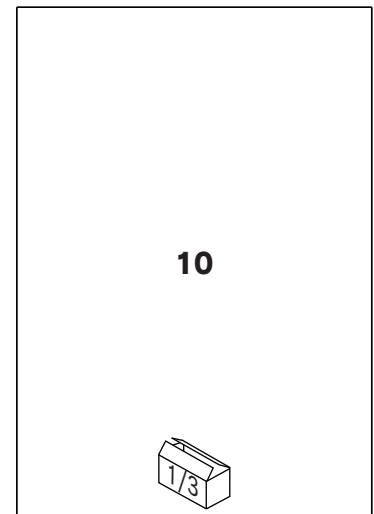

776 x 1112 mm.

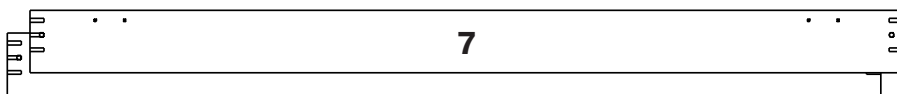

1910 x 137 mm.

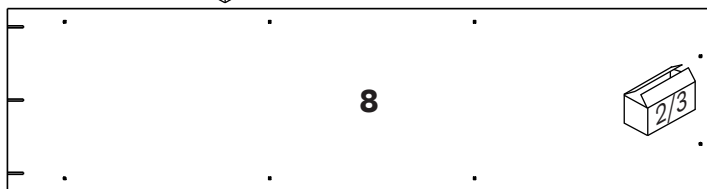

1545 x 400 mm.

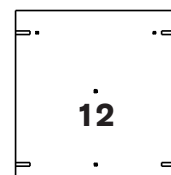

350 x 370 mm.

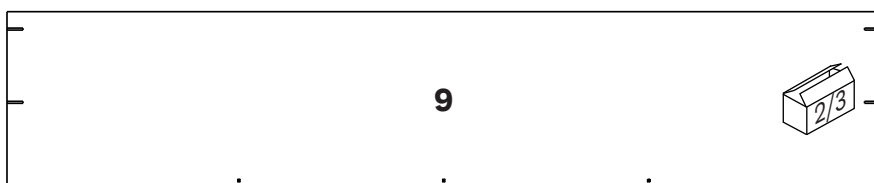

1910 x 382 mm.

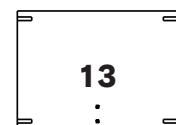

350 x 258 mm.

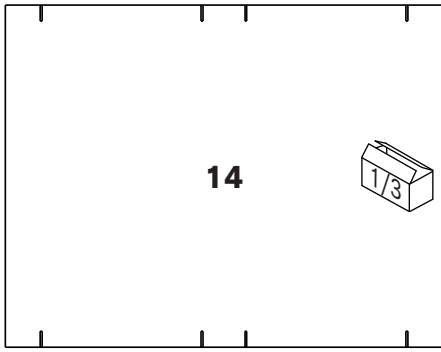

956 x 748 mm.

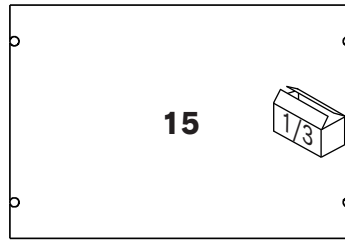

748 x 510 mm.

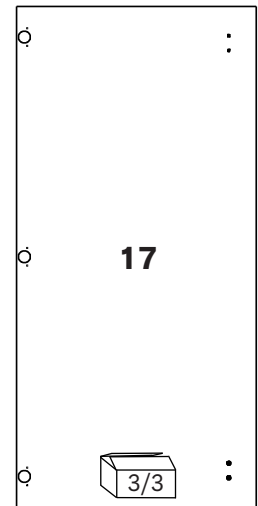

524 x 1094 mm.

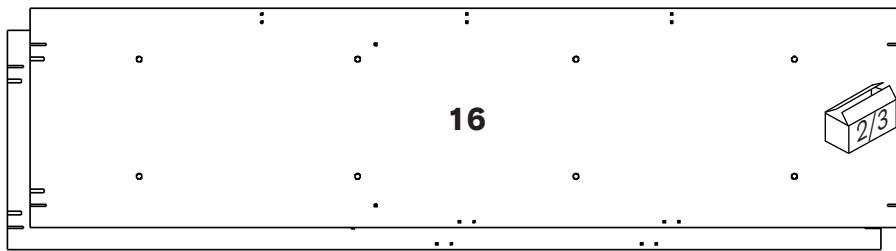

1910 x 479 mm.

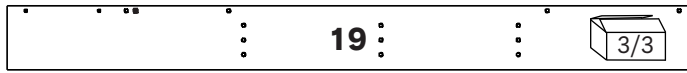

140 x 1502 mm.



140 x 1502 mm.

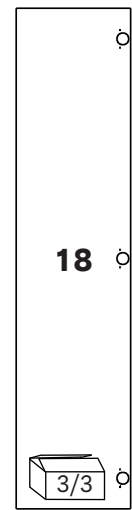

250 x 1094 mm.

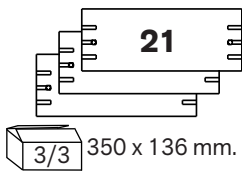

350 x 136 mm.

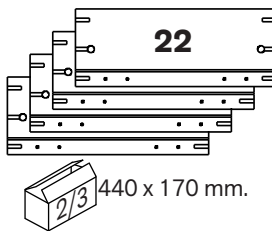

440 x 170 mm.

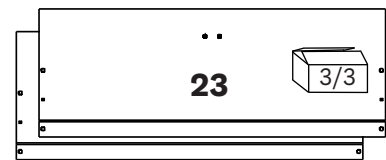

758 x 280 mm.

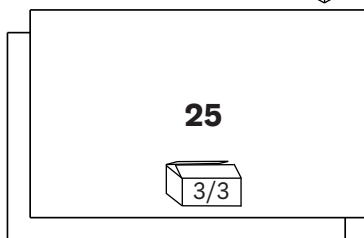

738 x 454 mm.

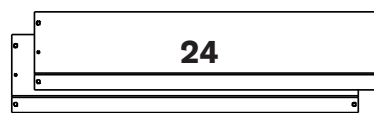

757 x 170 mm.

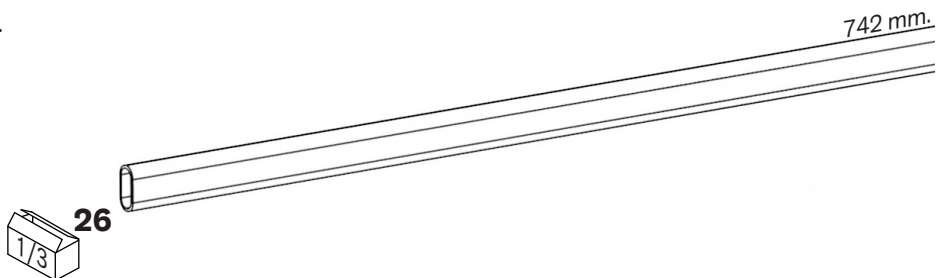

742 mm.

# Option A

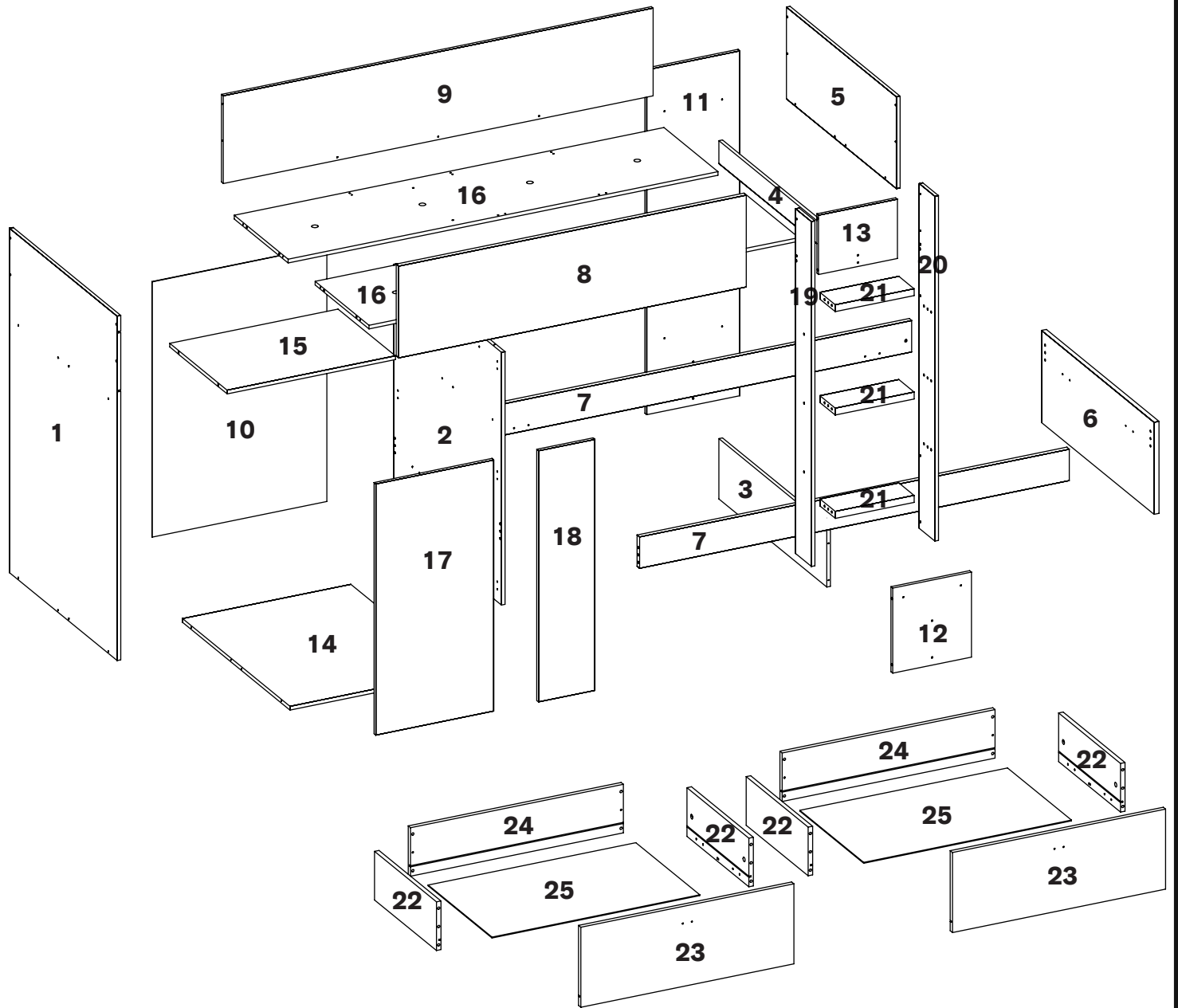

1

B x 03

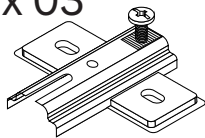

G x 08



3.5 x 15 mm.

R x 01

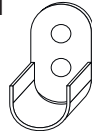

S x 04

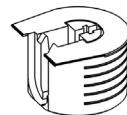

T x 02



Z x 03

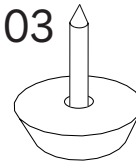

AH x 04



13 mm.

# Option A

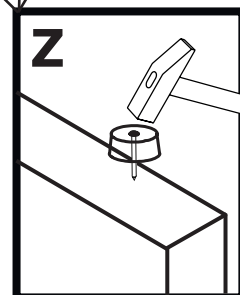
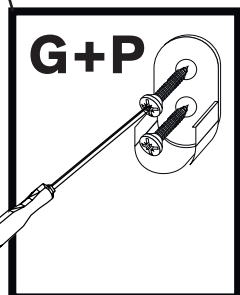
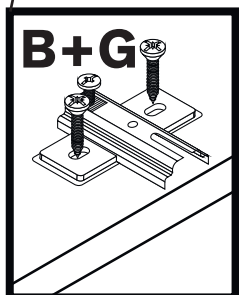
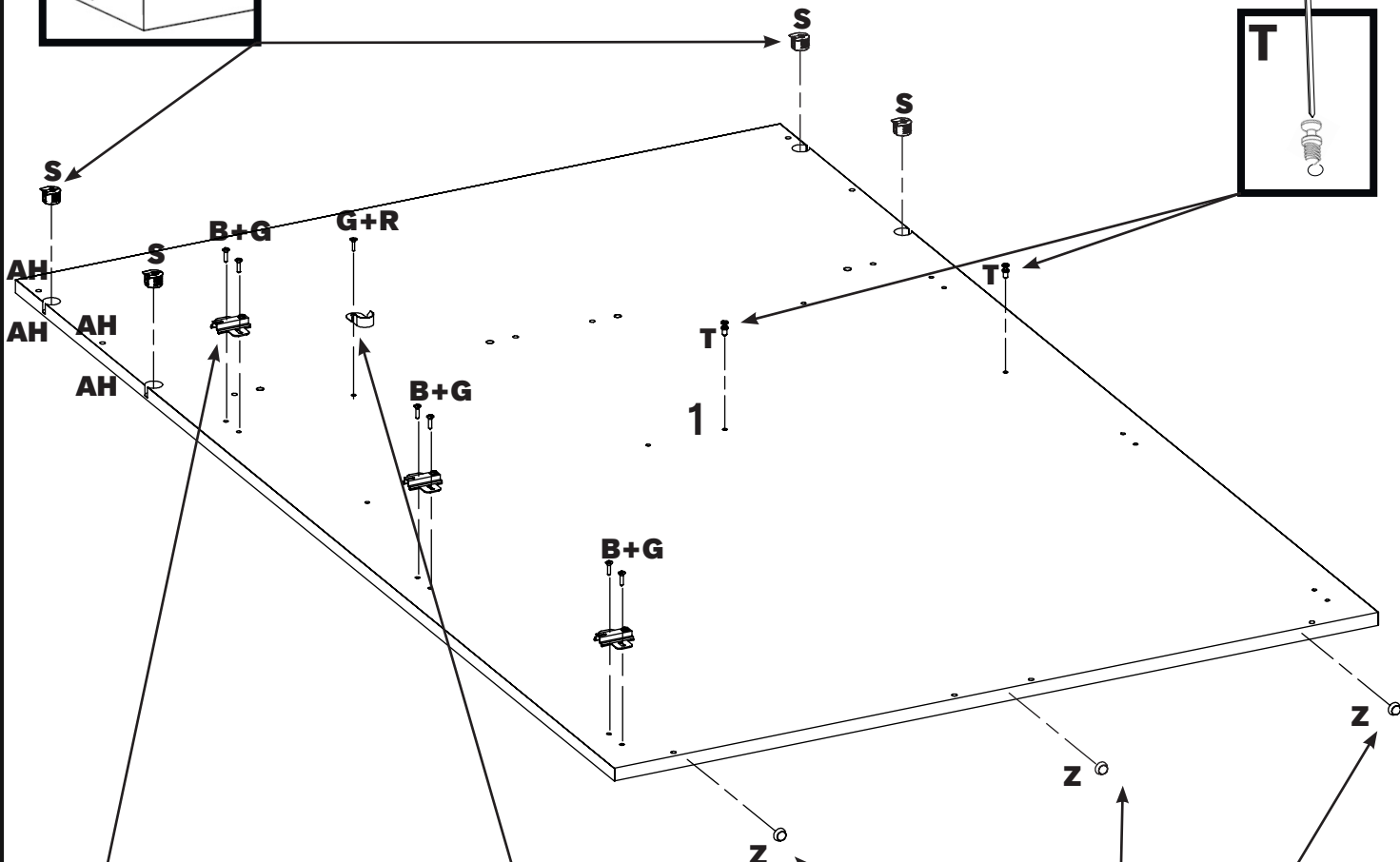
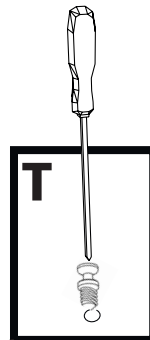
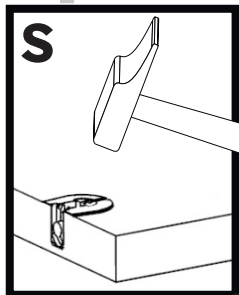

2

B x 03

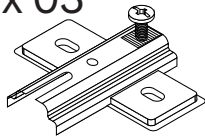

G x 08

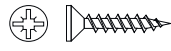

3.5 x 15 mm.

R x 01

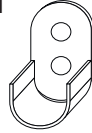

T x 02

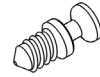

Z x 03

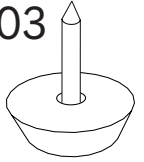

# Option A

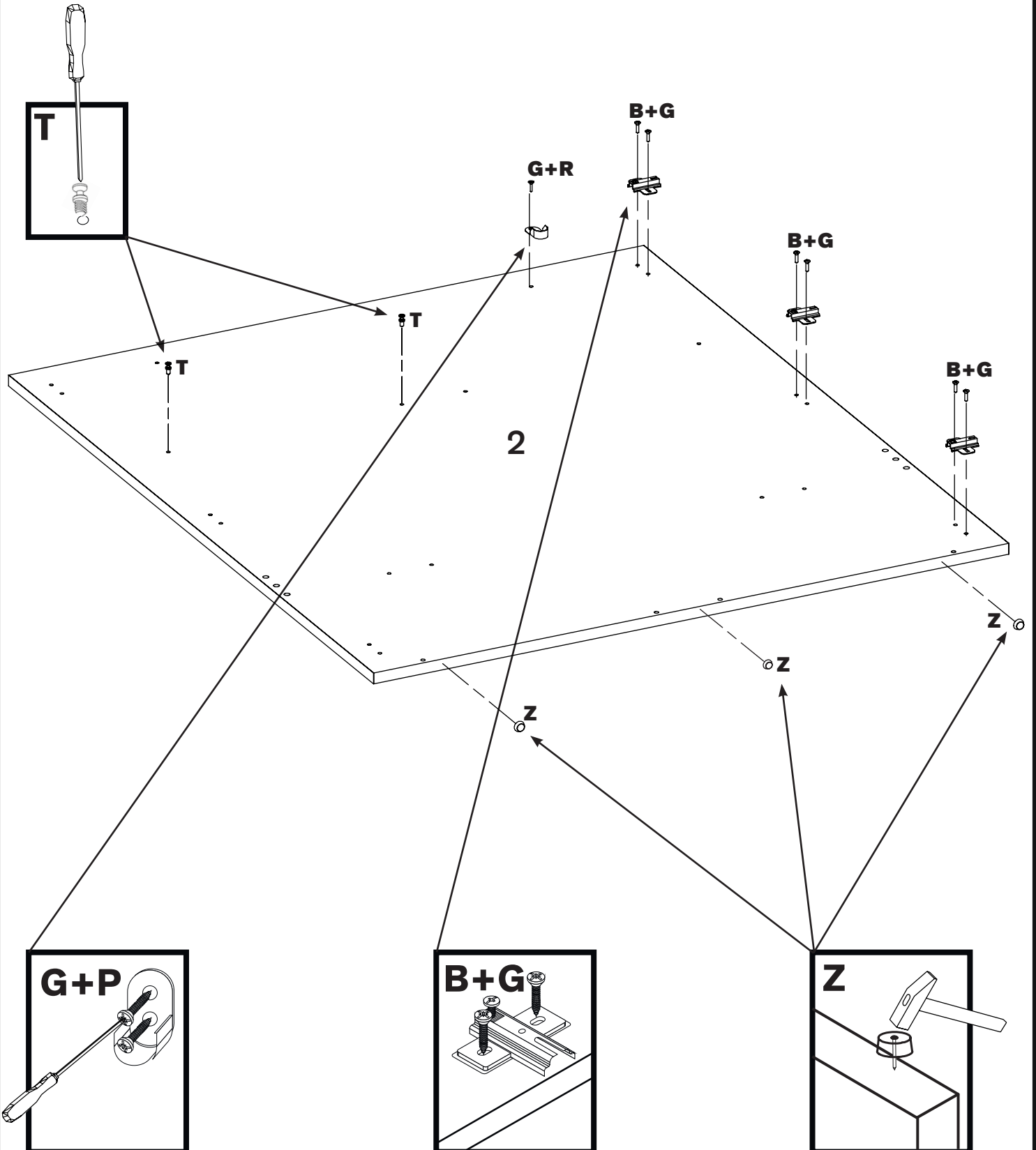

3 S x 04



# Option A

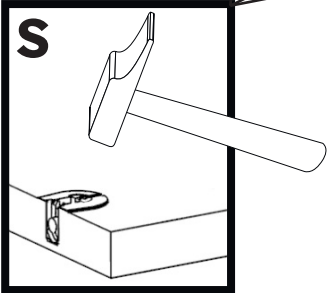
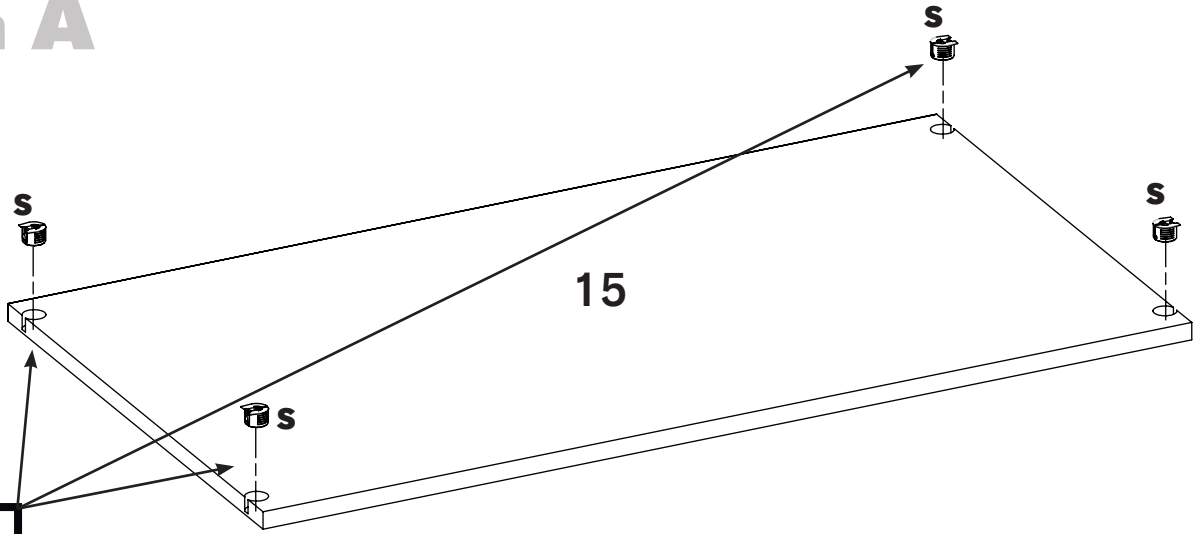

4 N x 08

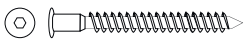

5 x 50 mm.

AD x 01

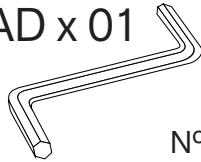

N° 3

AF x 08



3 mm.

# Option A

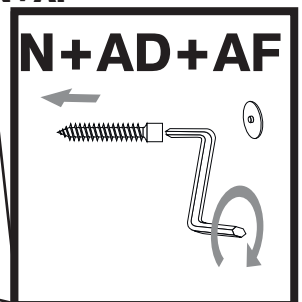
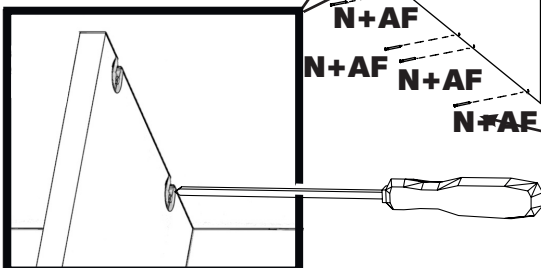
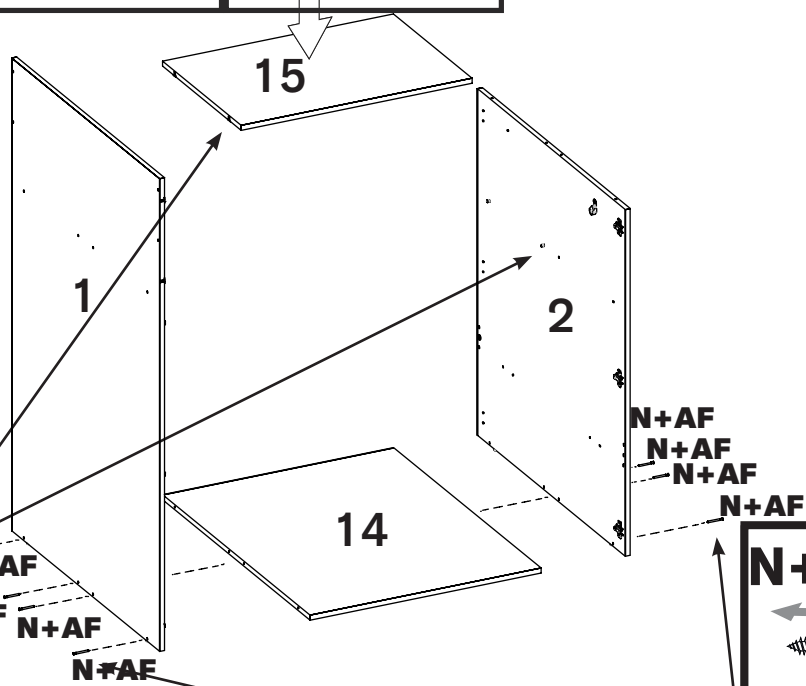

5 C x 04

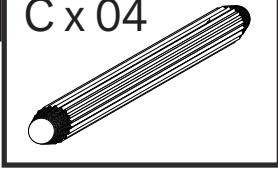

## Option A

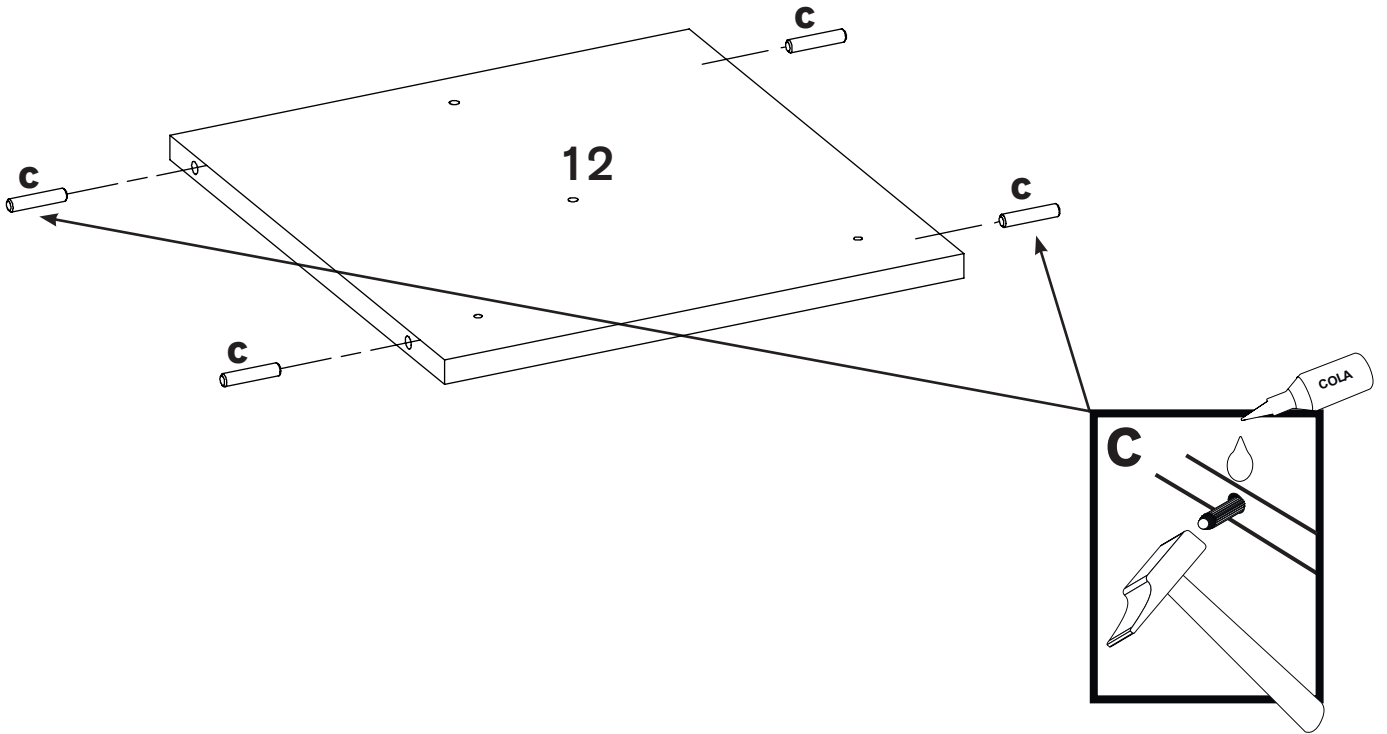

6 C x 04

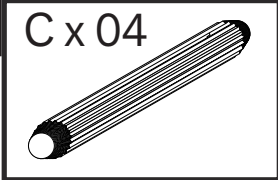

## Option A

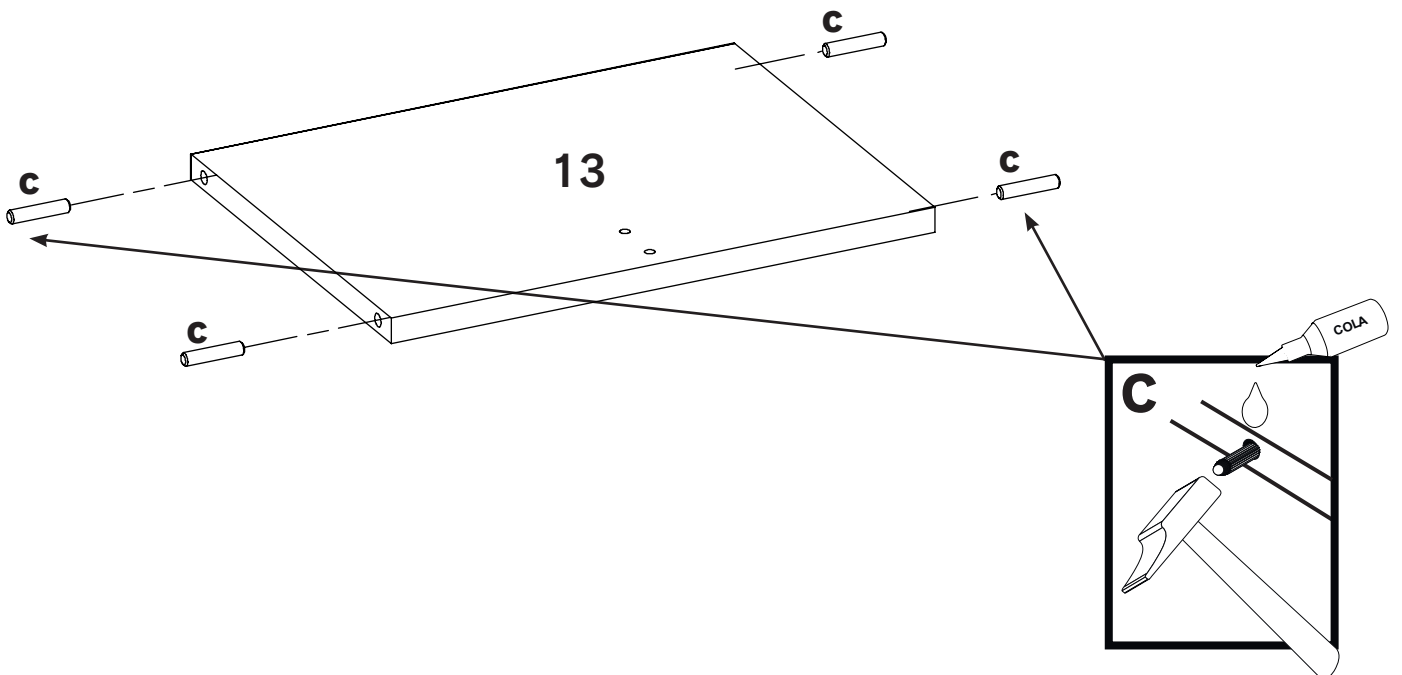



7

C x 12

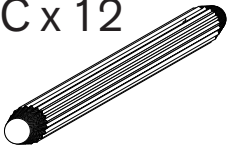

Q x 06



21 mm.

# Option A

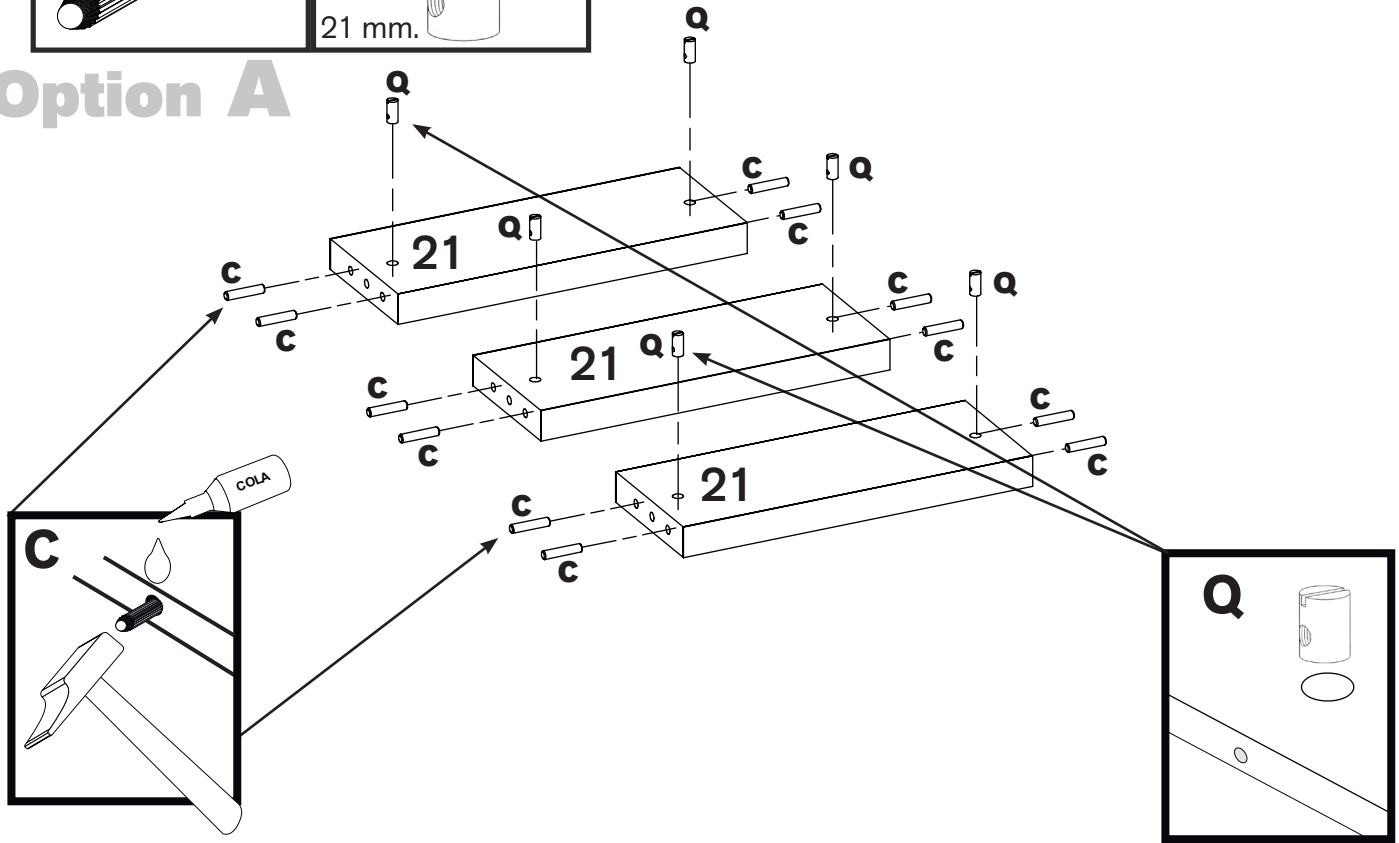

8

N x 02



5 x 50 mm.

O x 06



M6 x 60 mm.

Z x 02



AD x 01

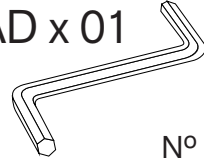

Nº 3

AE x 01

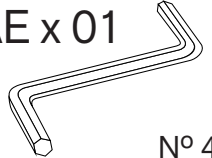

Nº 4

# Option A

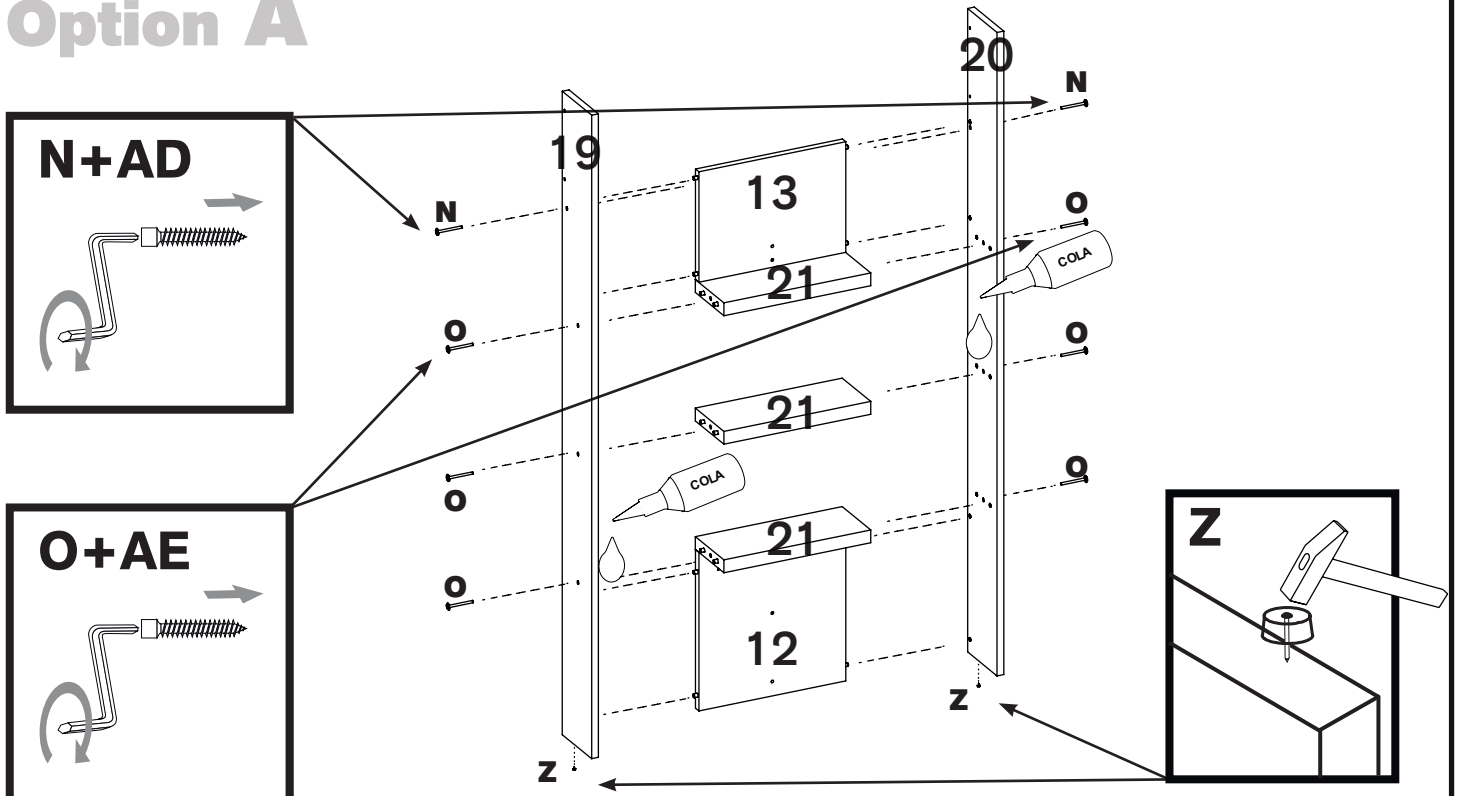

9

N x 08

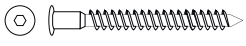

5 x 50 mm.

Z x 04



AD x 01

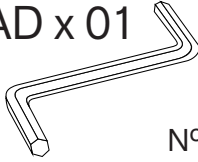

Nº 3

AH x 04



13 mm.

# Option A

N  
N

11

N

N

4

19

20

13

N+AH  
N+AH

3

Z

Z

12

N+AH

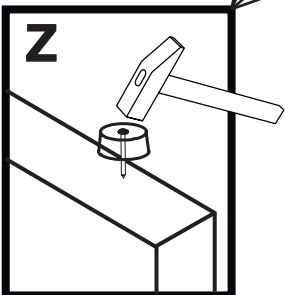

N+AH

Z



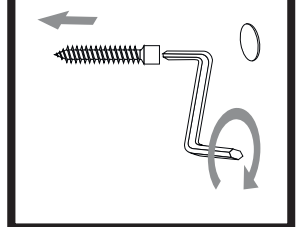

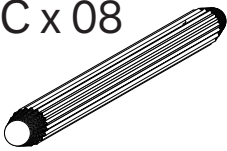
N+AD+AH

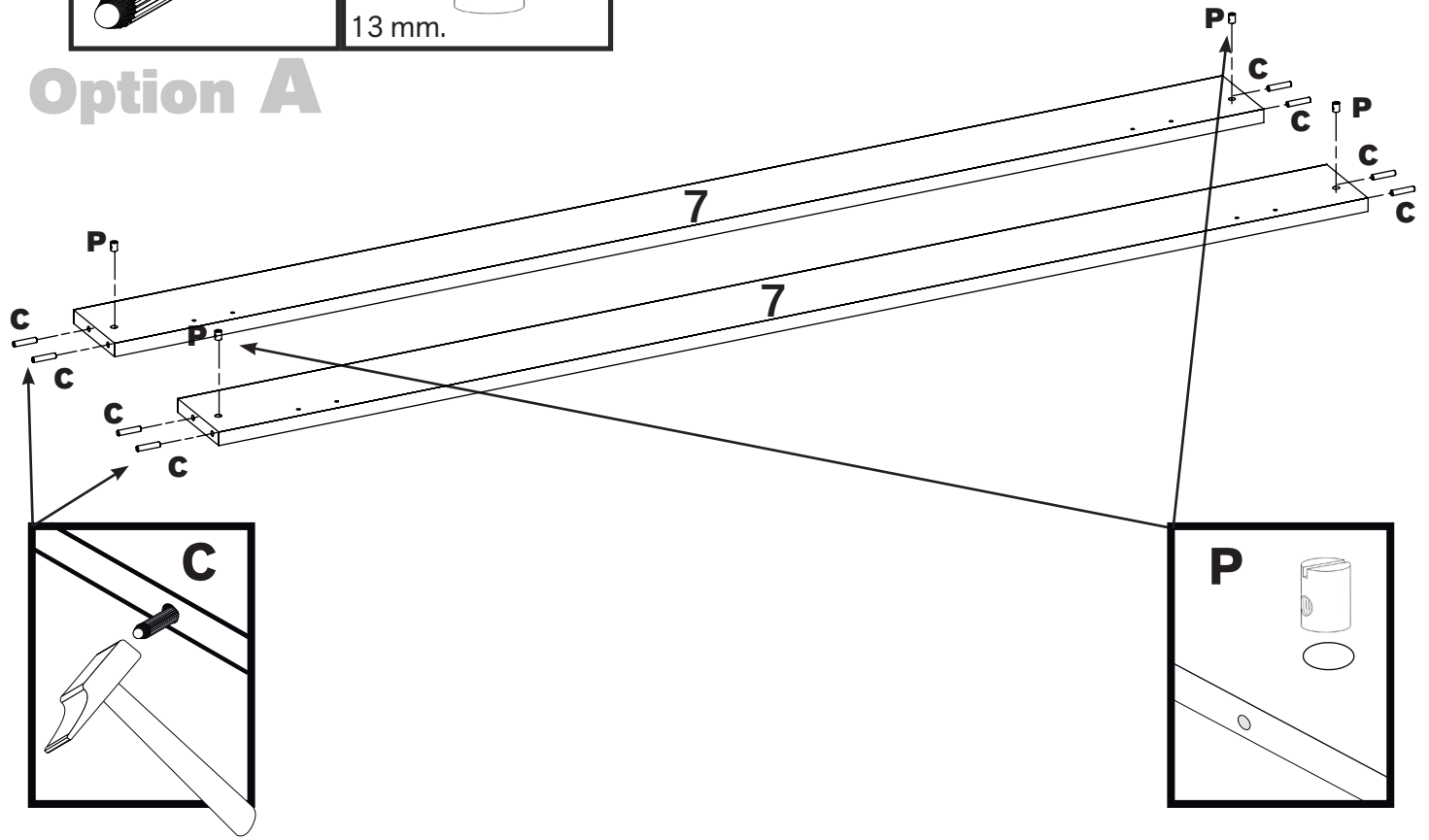

**10** C x 08      P x 04  
        
 13 mm.

**Option A**

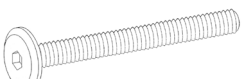

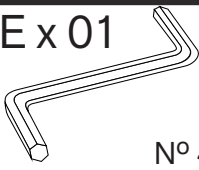
**11** O x 04      Z x 02      AE x 01  
              
 M6 x 60 mm.      N° 4

**Option A**

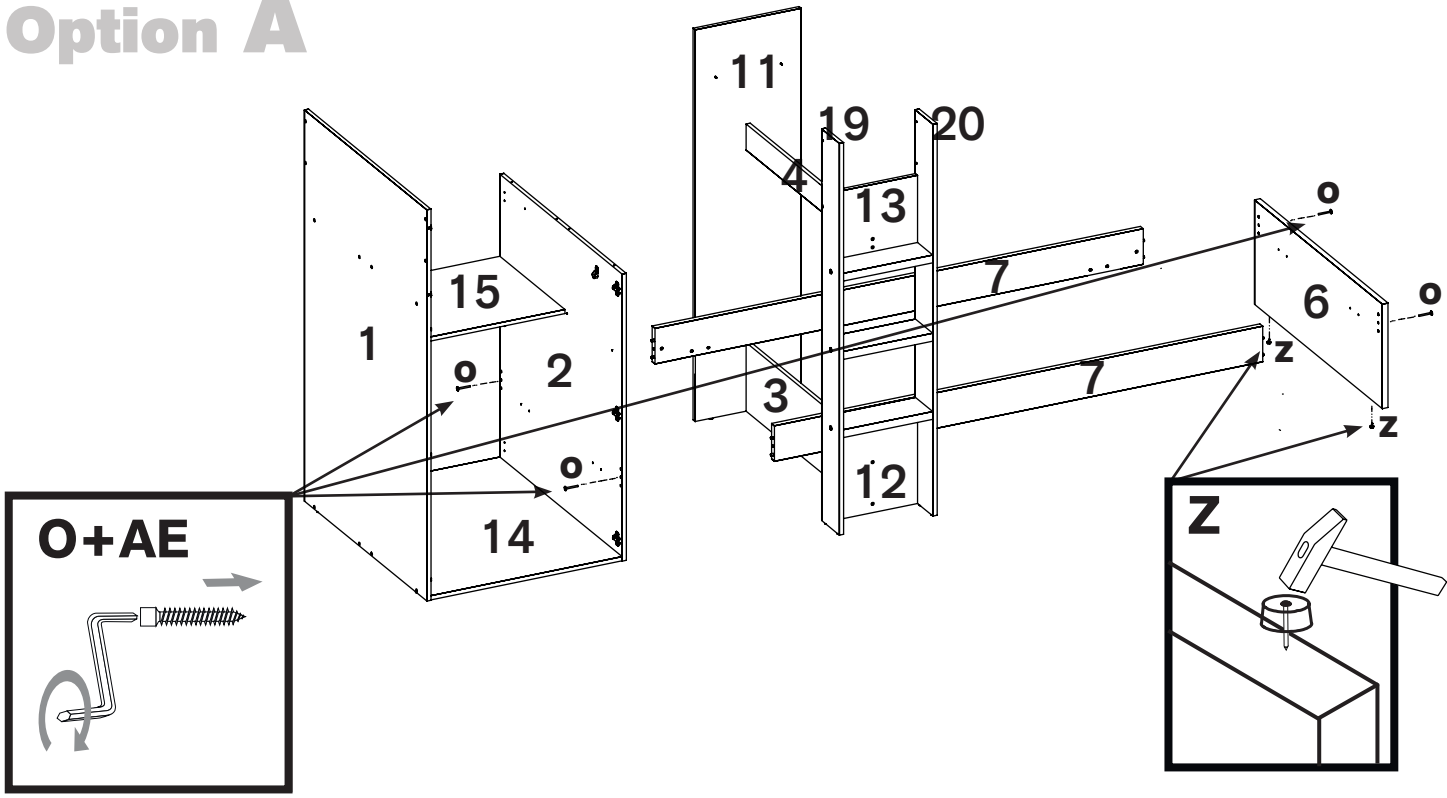

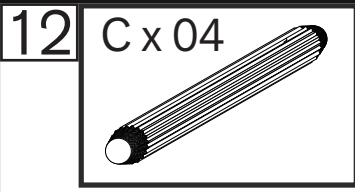

**Option A**

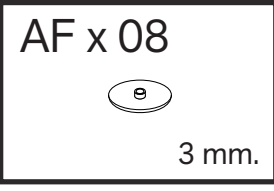
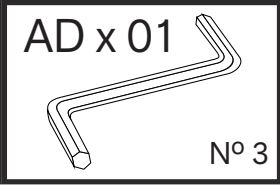
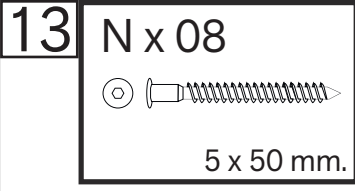
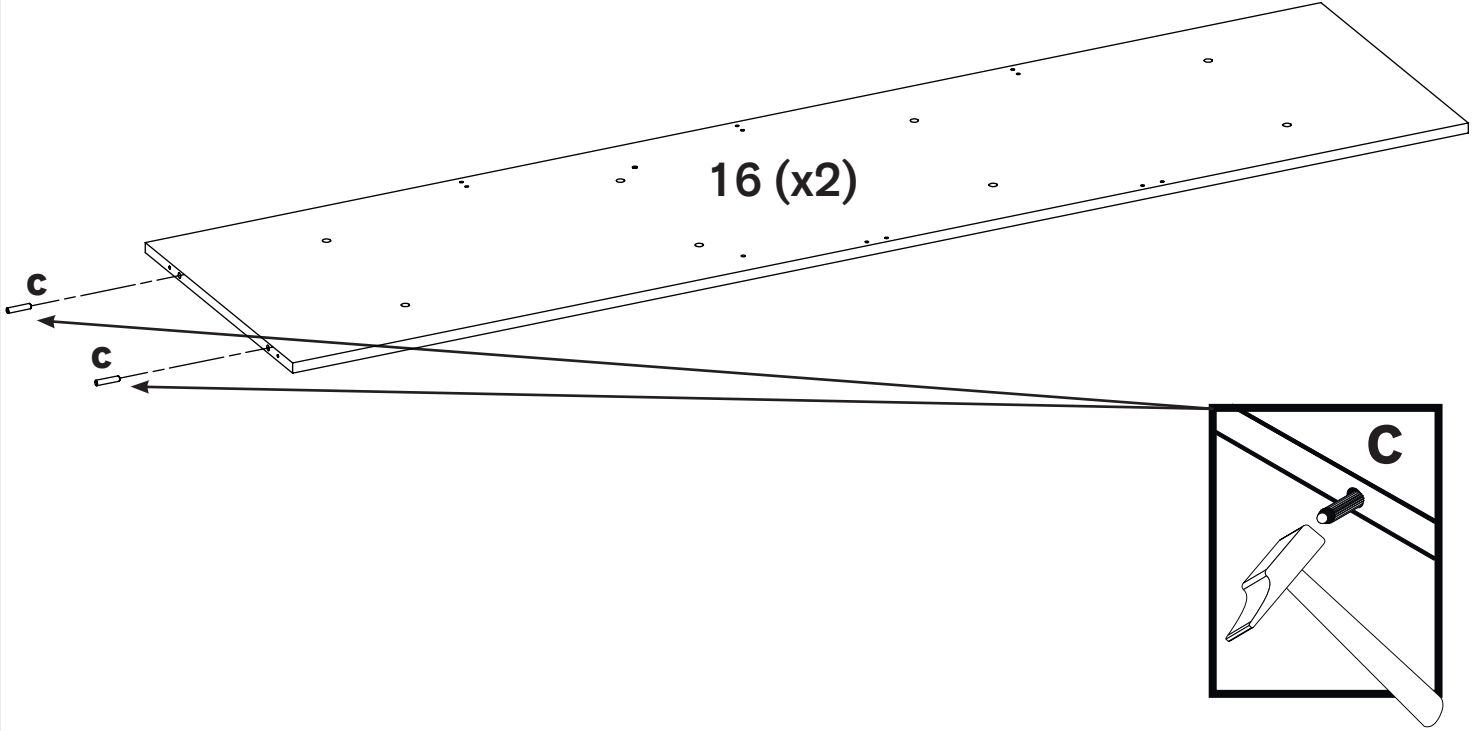

**Option A**

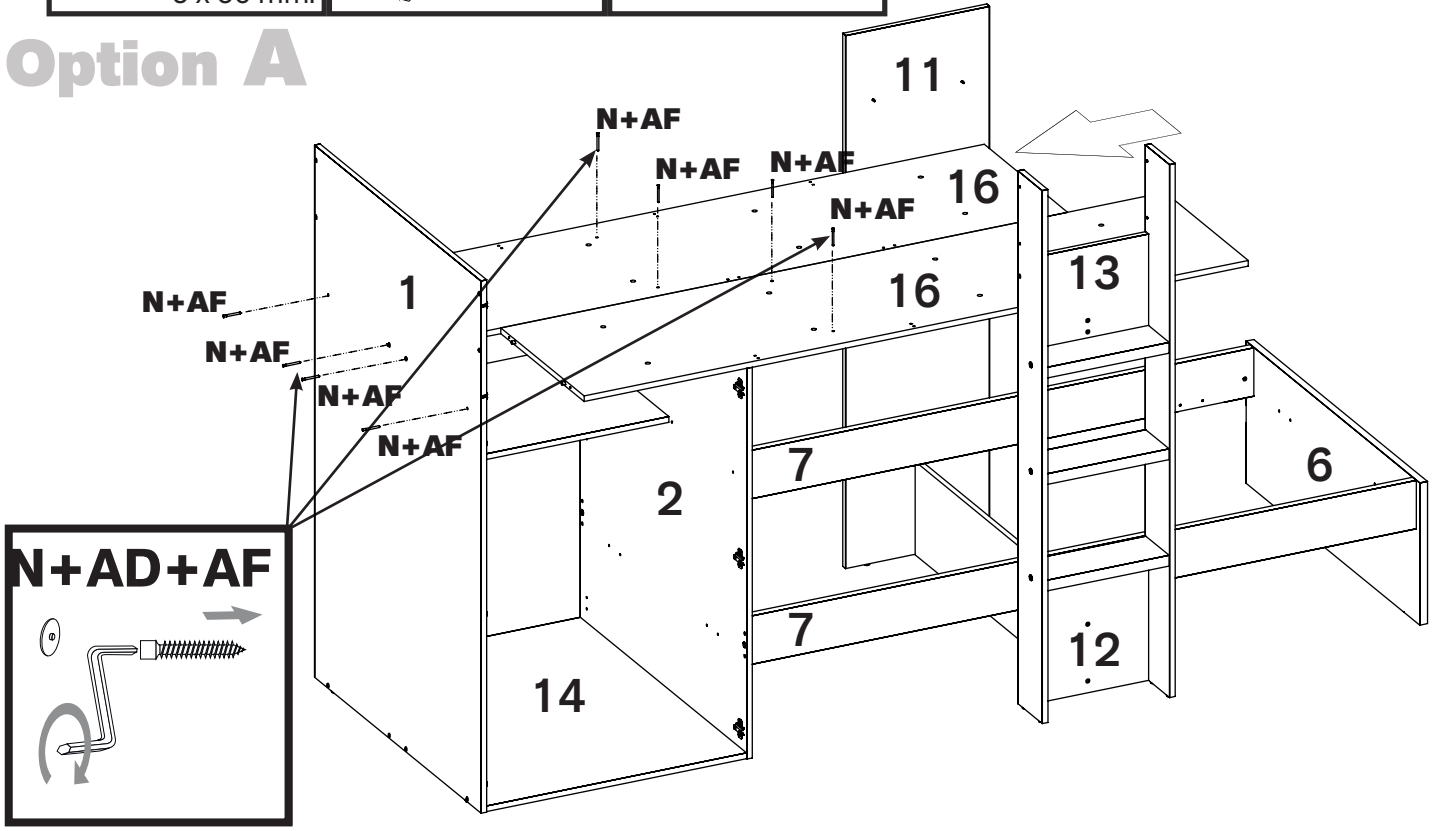

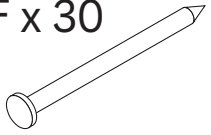
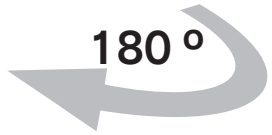

14 F x 30



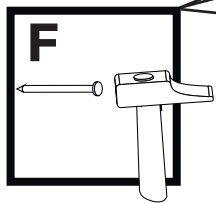
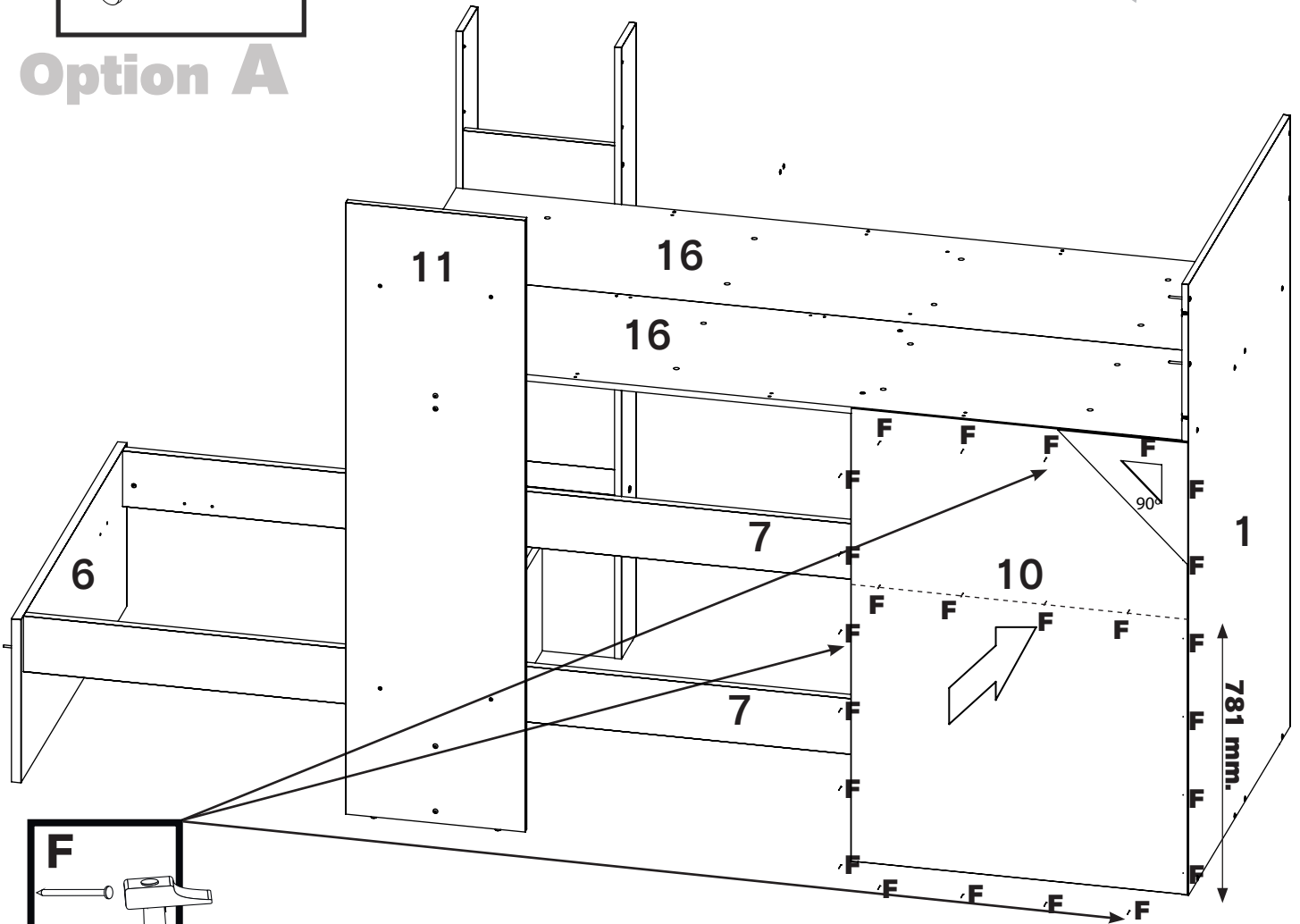

Option A





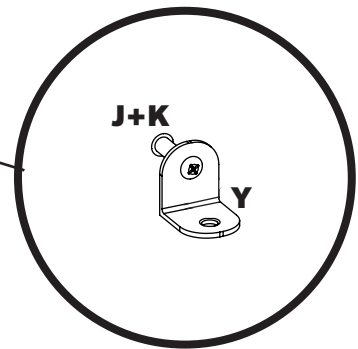
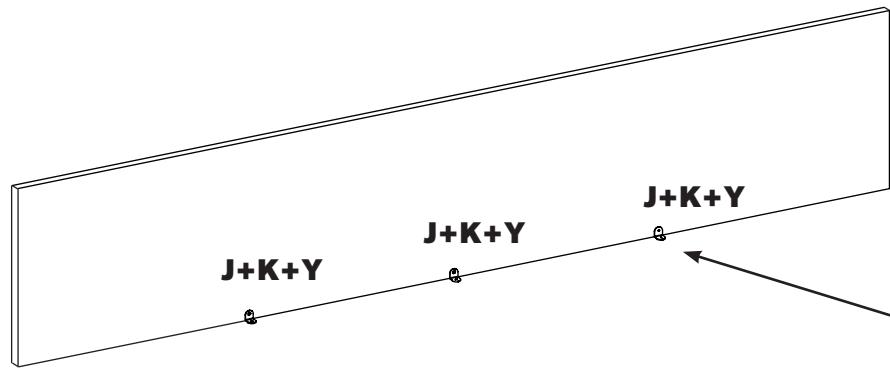

15 J x 03  
  
 M4 x 10 mm.

K x 03  
  
 M4 x 15 mm.

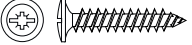
Y x 03  

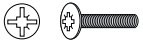
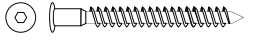
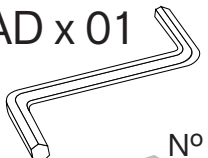





<b>16</b> <b>I x 02</b>  4 x 27 mm.	<b>K x 02</b>  M4 x 15 mm.	<b>L x 02</b>  M4 x 25 mm.	<b>N x 08</b>  5 x 50 mm.	<b>AD x 01</b>  Nº 3
---	---	---	---	---

<b>AF x 08</b>  3 mm.
--

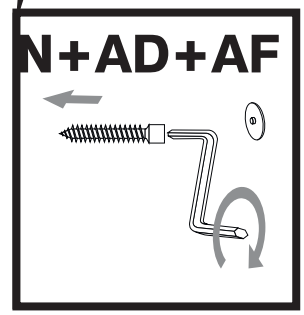
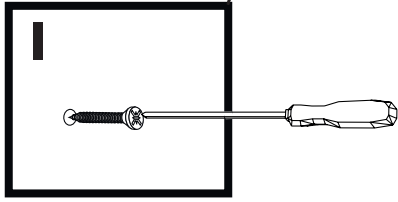
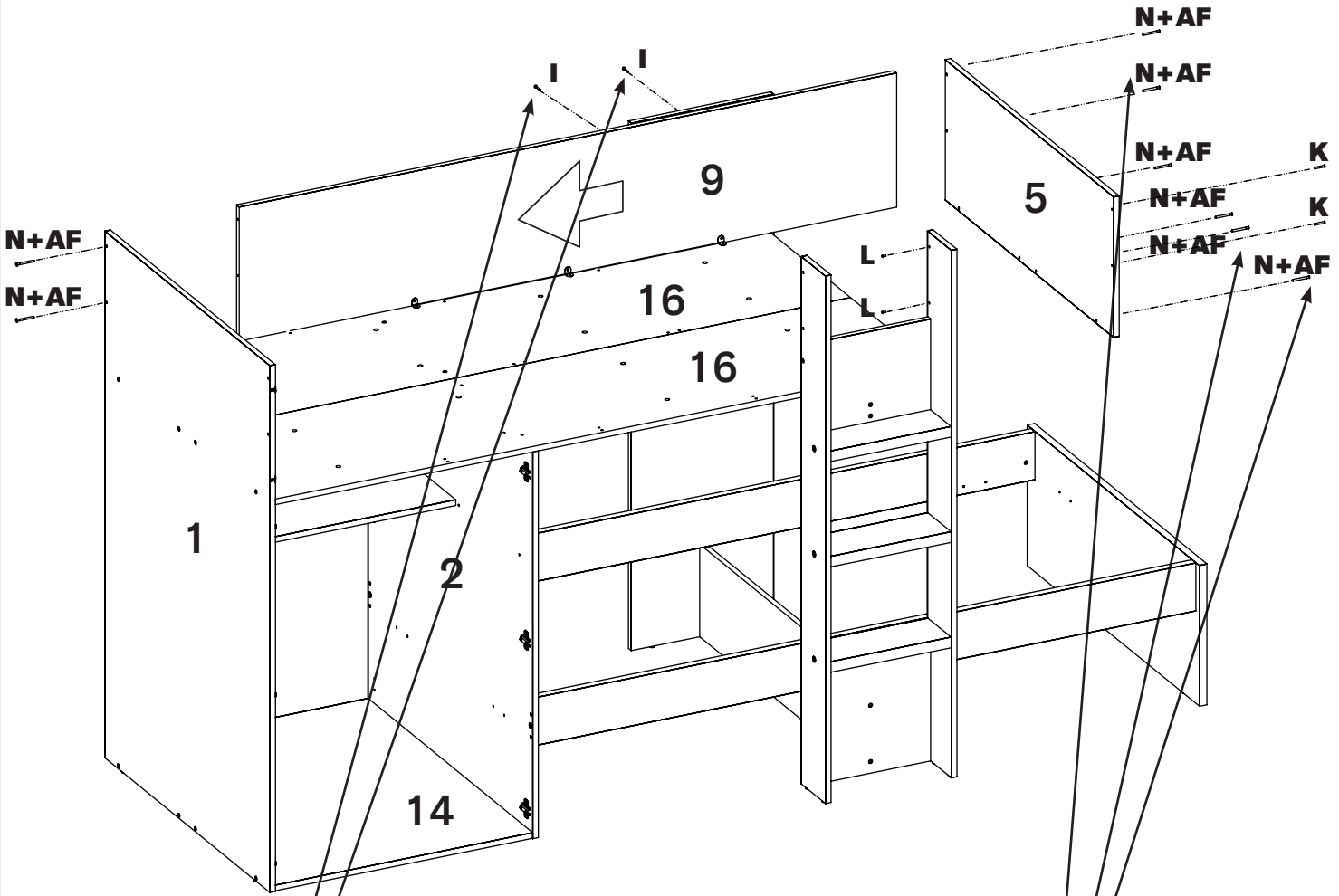

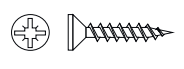
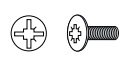
# Option A

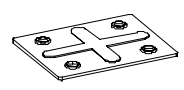

17	<b>G x 08</b>  3.5 x 15 mm.	<b>J x 03</b>  M4 x 10 mm.	<b>K x 03</b>  M4 x 15 mm.	<b>AB x 02</b> 	<b>AH x 08</b>  13 mm.
----	--	---	---	---	---

# Option A

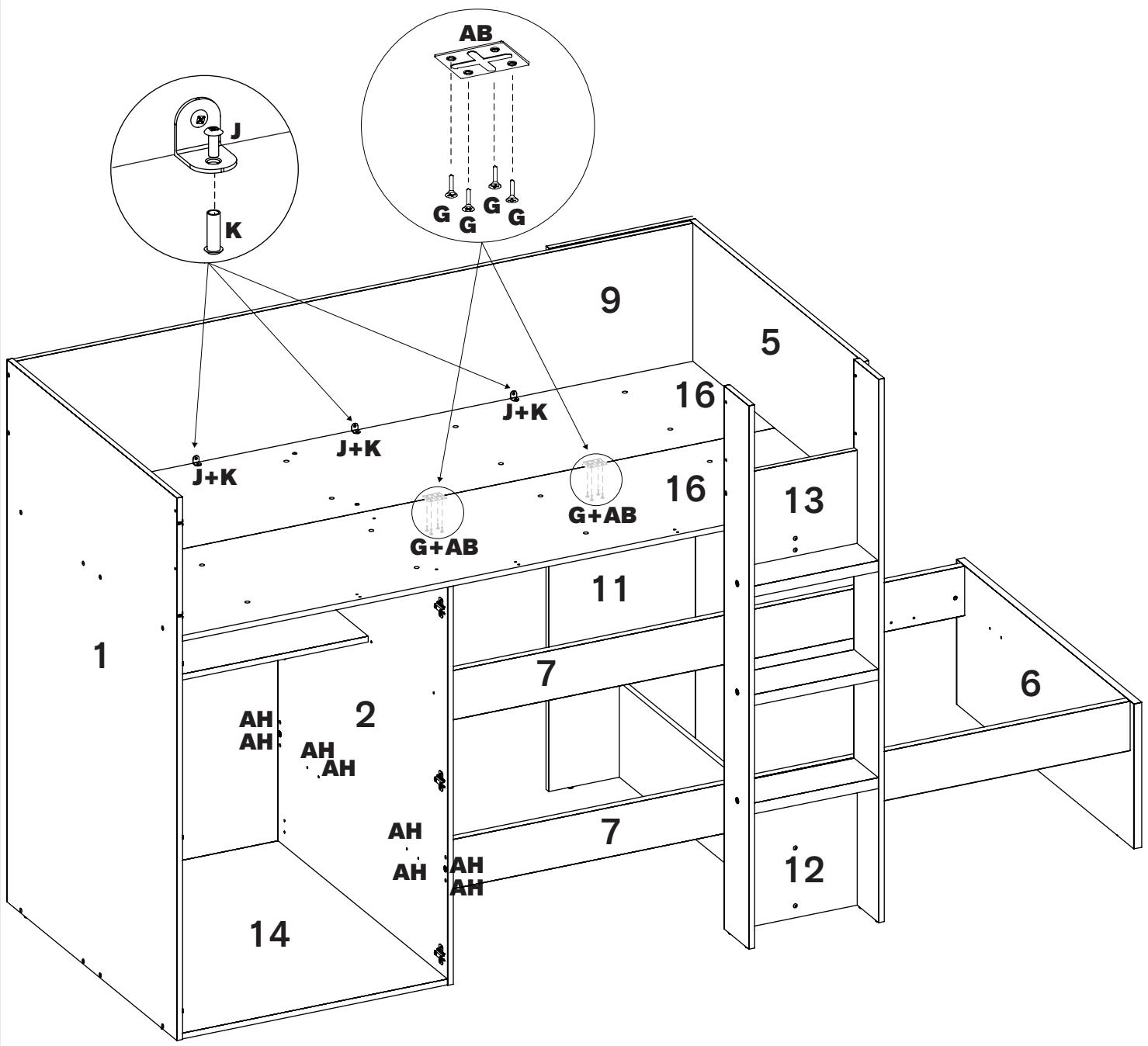

18

G x 05



3.5 x 15 mm.

T x 02



Y x 05



# Option A

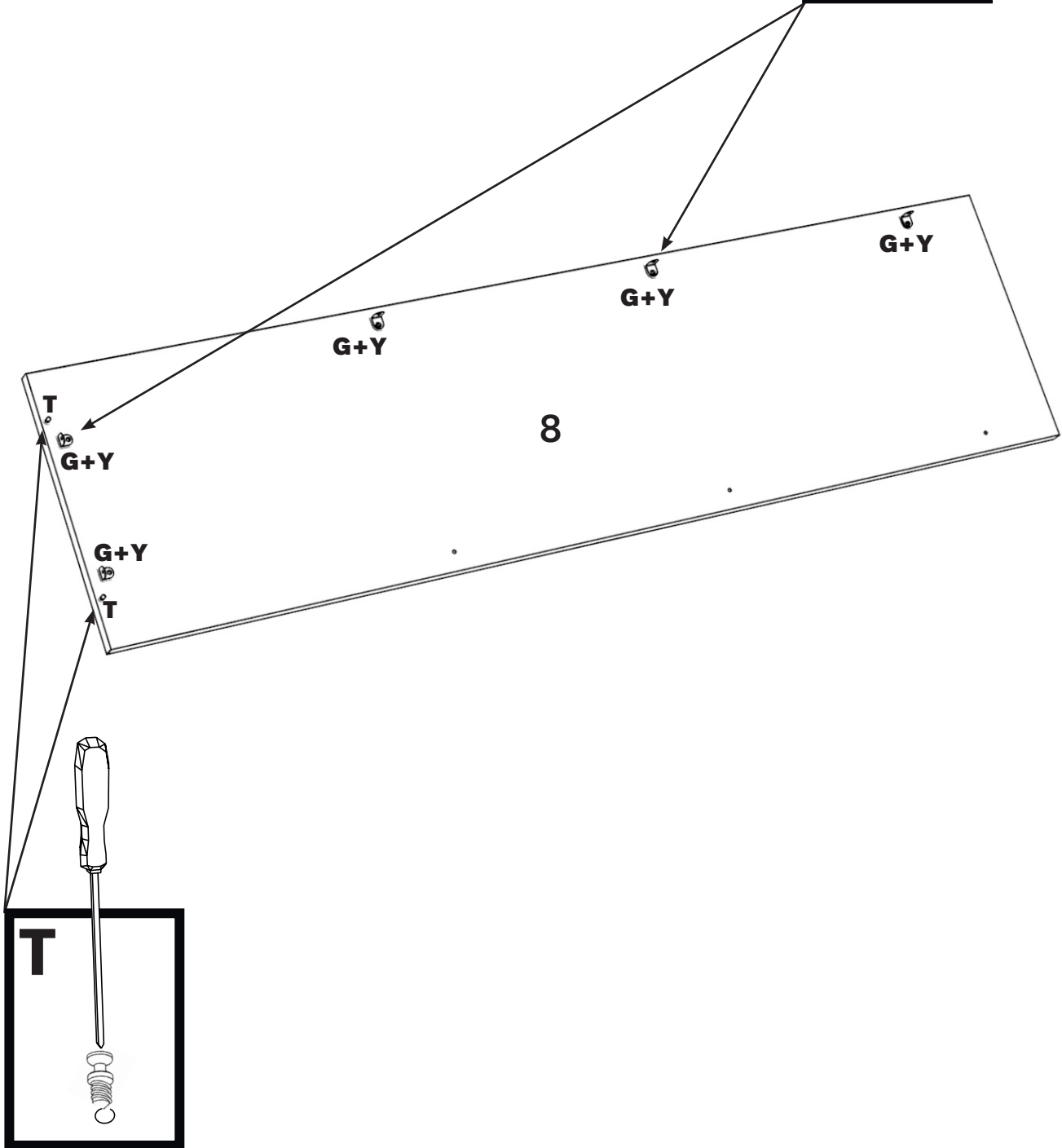
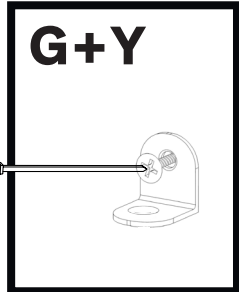



19

G x 02



3.5 x 15 mm.

J x 03



M4 x 10 mm.

K x 03



M4 x 15 mm.

N x 02



5 x 50 mm.

AD x 01

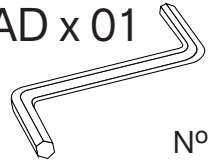

N° 3





AH x 02

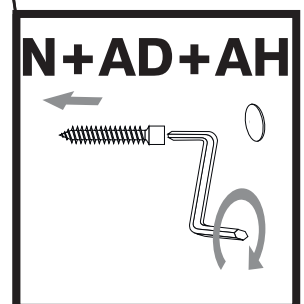
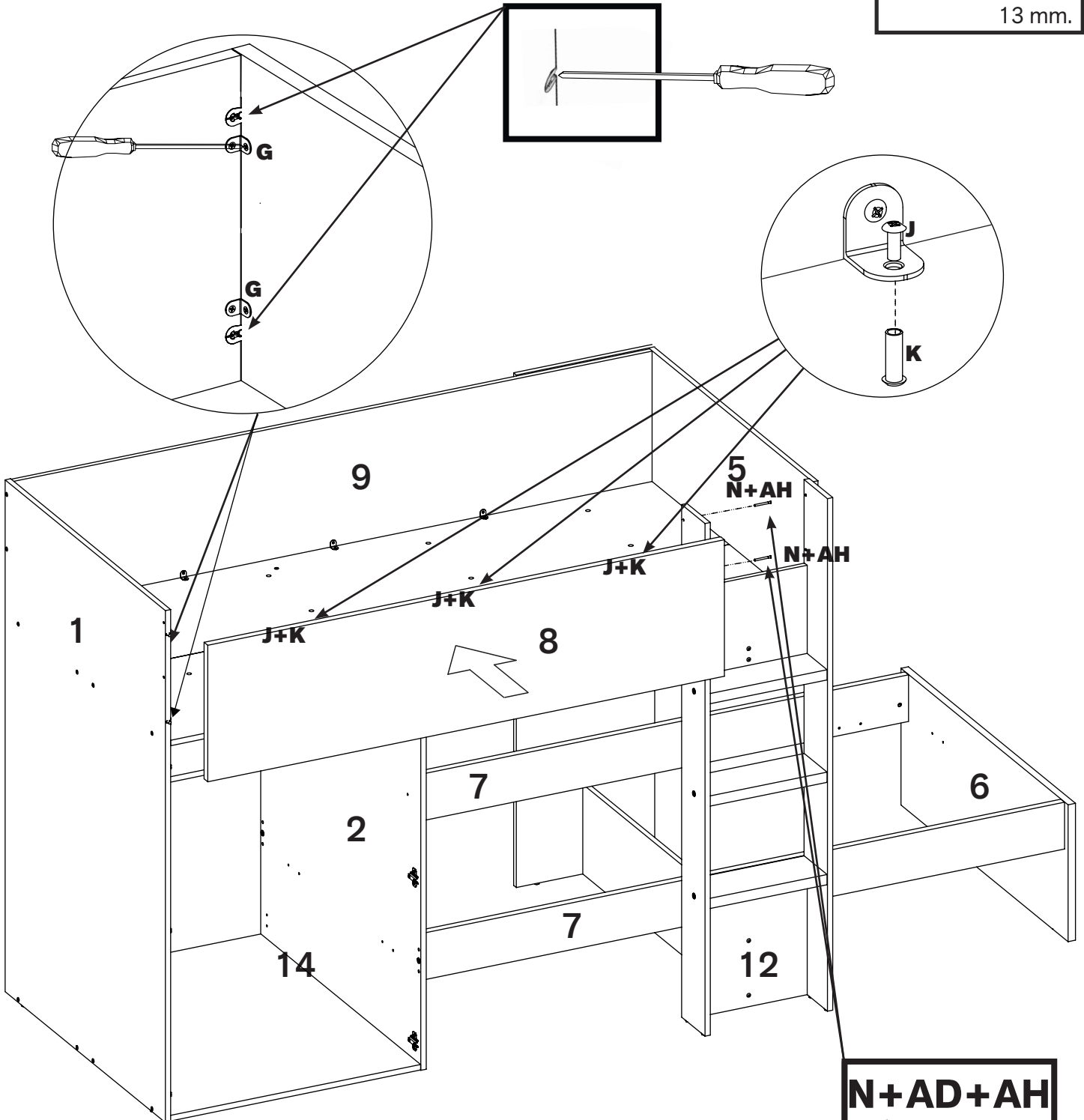

13 mm.

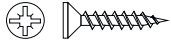
# Option A

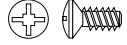

20	<b>G x 24</b>  3.5 x 15 mm.	<b>M x 04</b>  3.5 x 30 mm.	<b>Ñ x 16</b>  6.3 x 14 mm.	<b>U x 04</b> 	<b>AH x 02</b>  13 mm.
----	--	--	--	---	---

# Option A

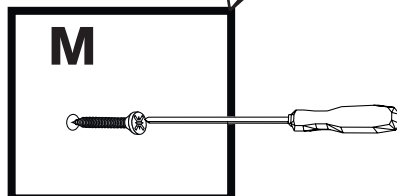
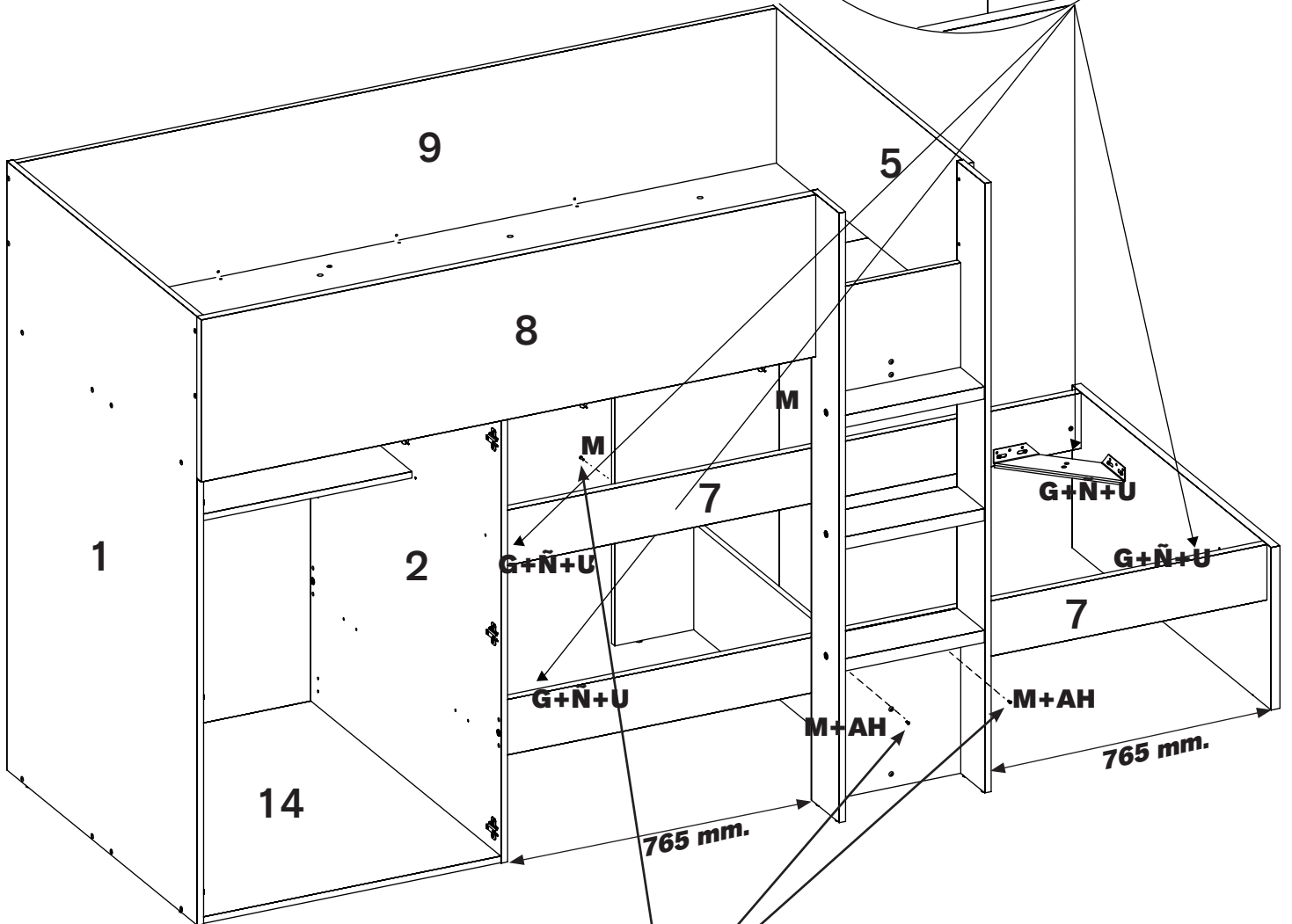
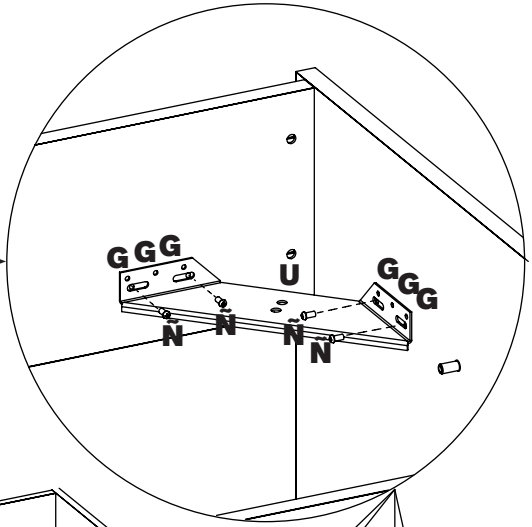
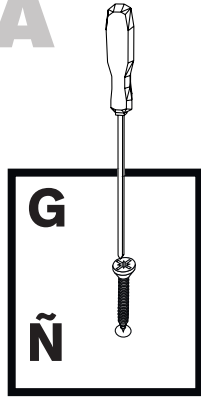

21

A x 03

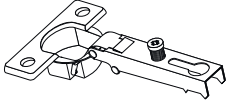

G x 06

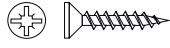

3.5 x 15 mm.

# Option A

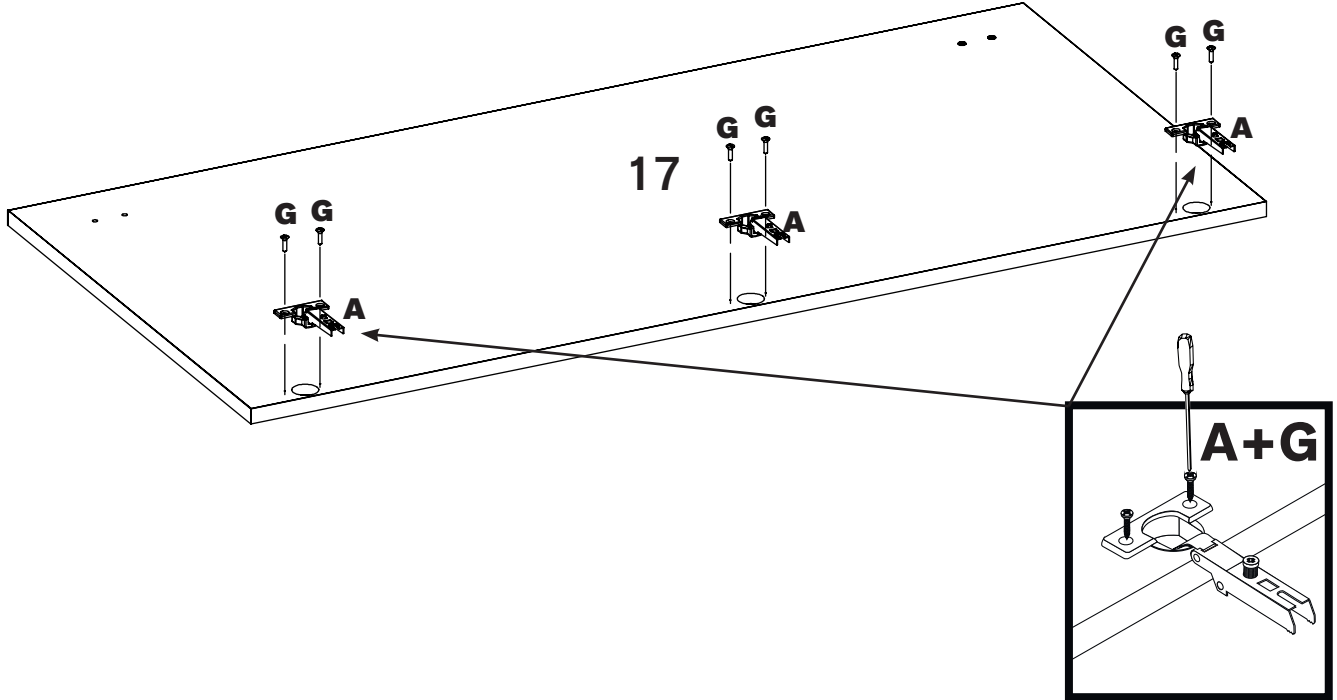

22

A x 03

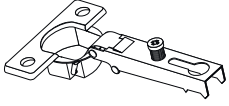

G x 06



3.5 x 15 mm.

# Option A

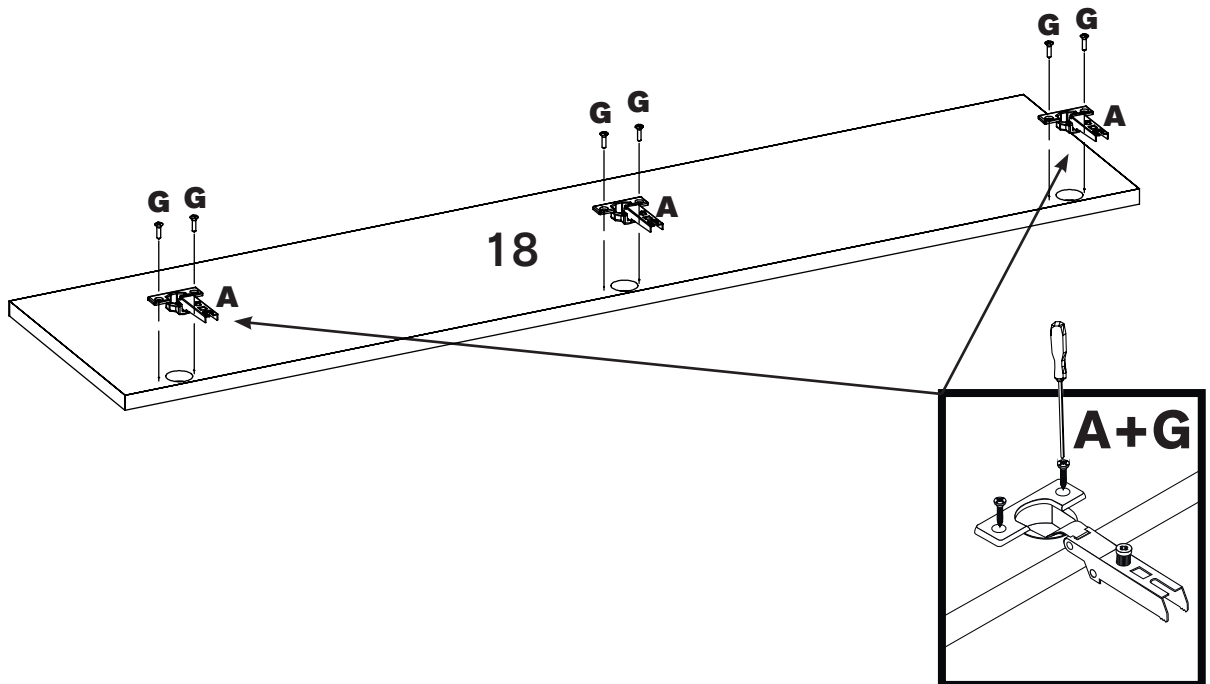

23

C x 16

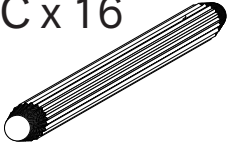

E x 08

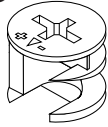

G x 16

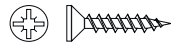

3.5 x 15 mm.

W x 08

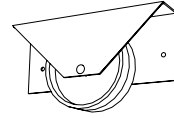

### Option A

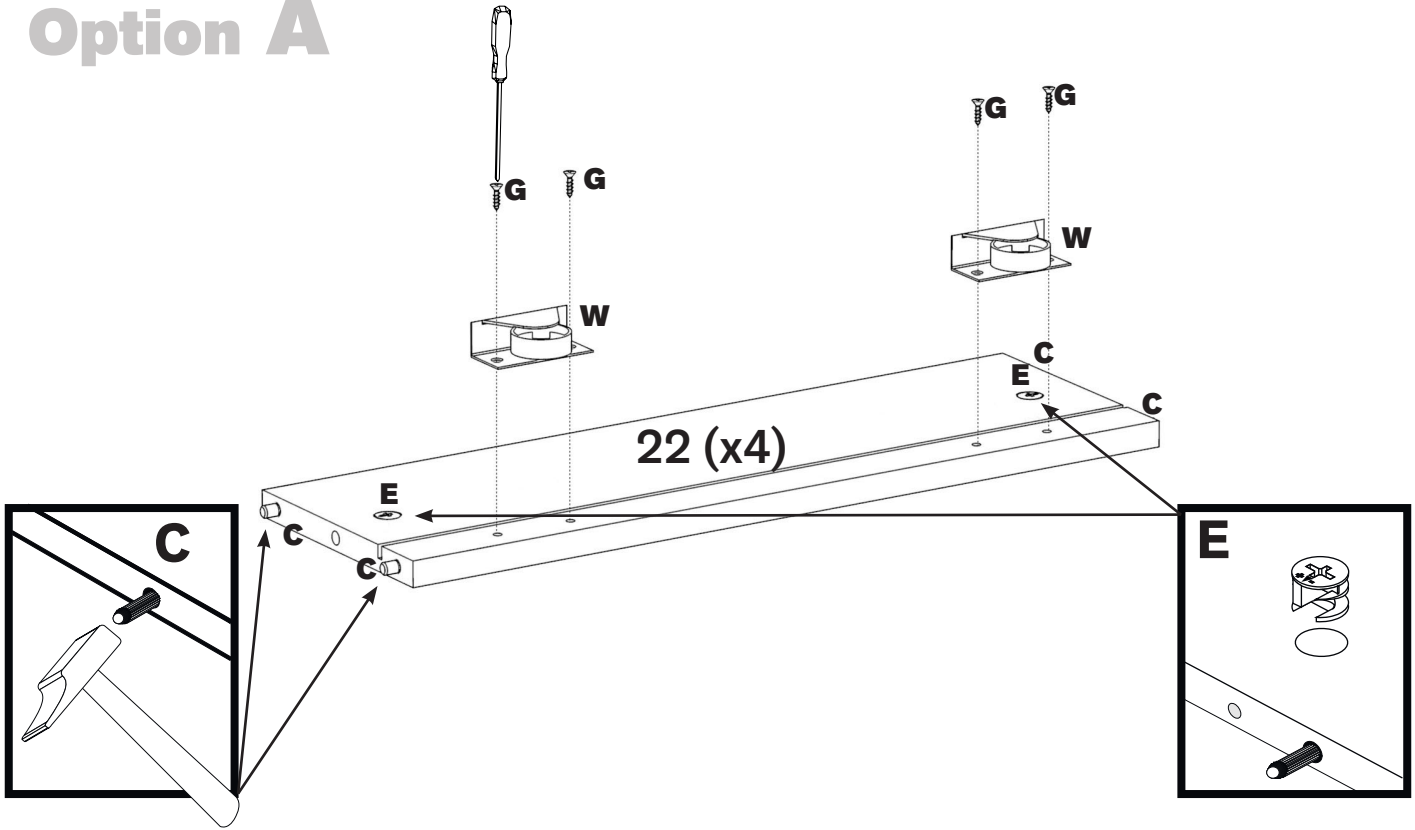

24

D x 04

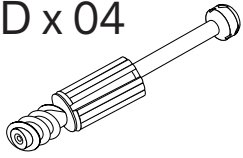

### Option A

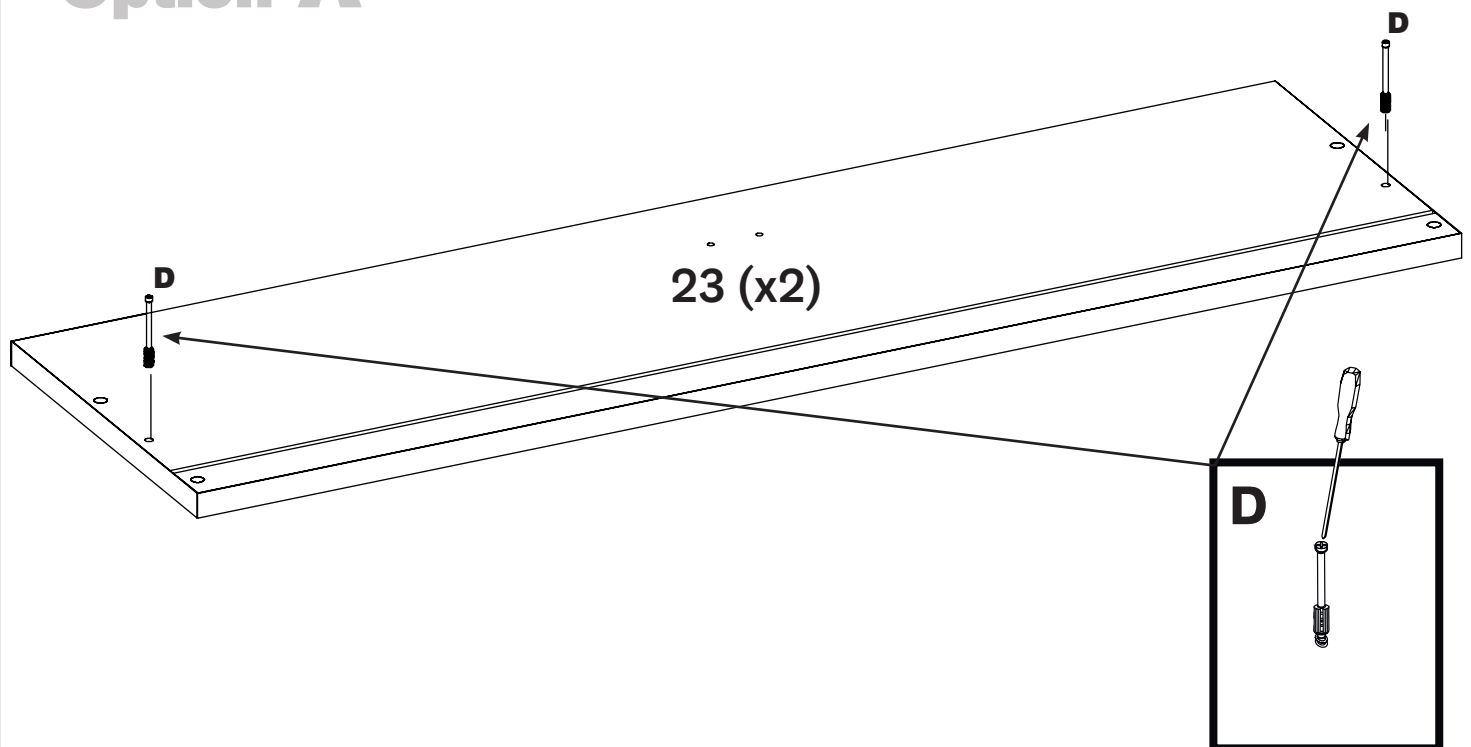

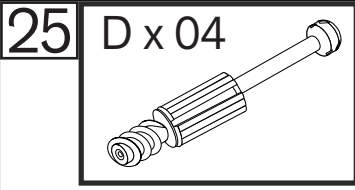

**Option A**

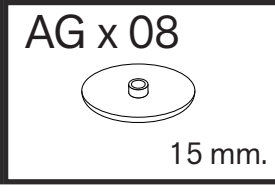
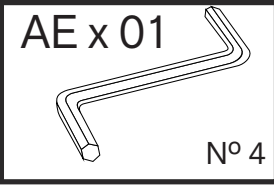
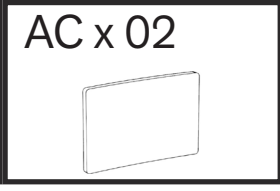
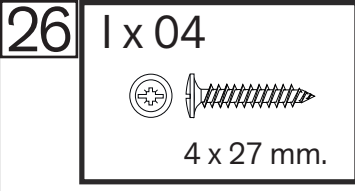
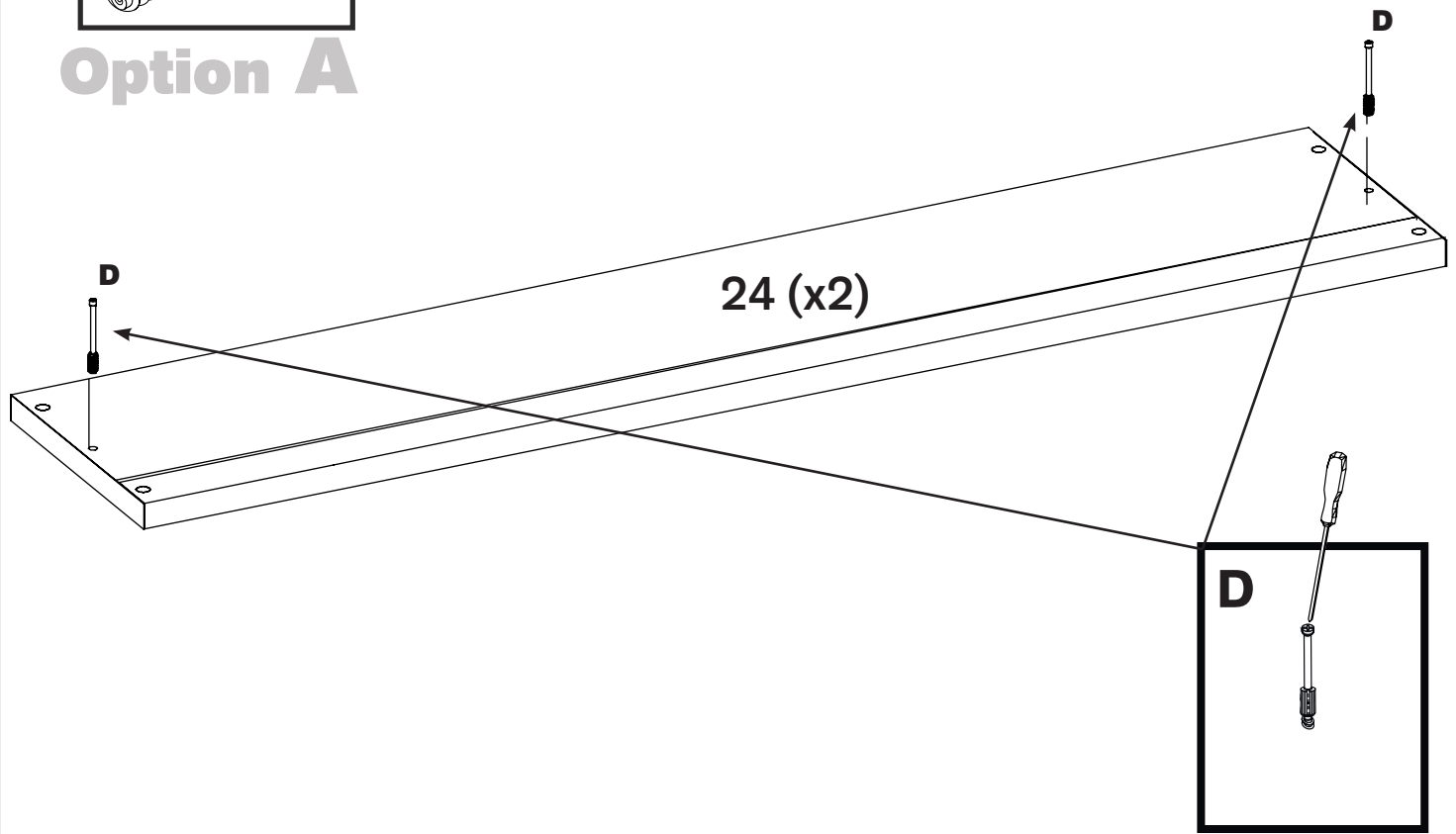

**Option A**

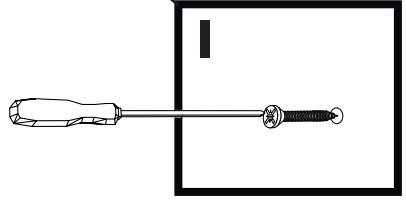
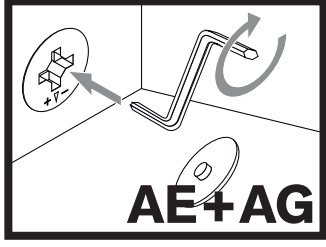
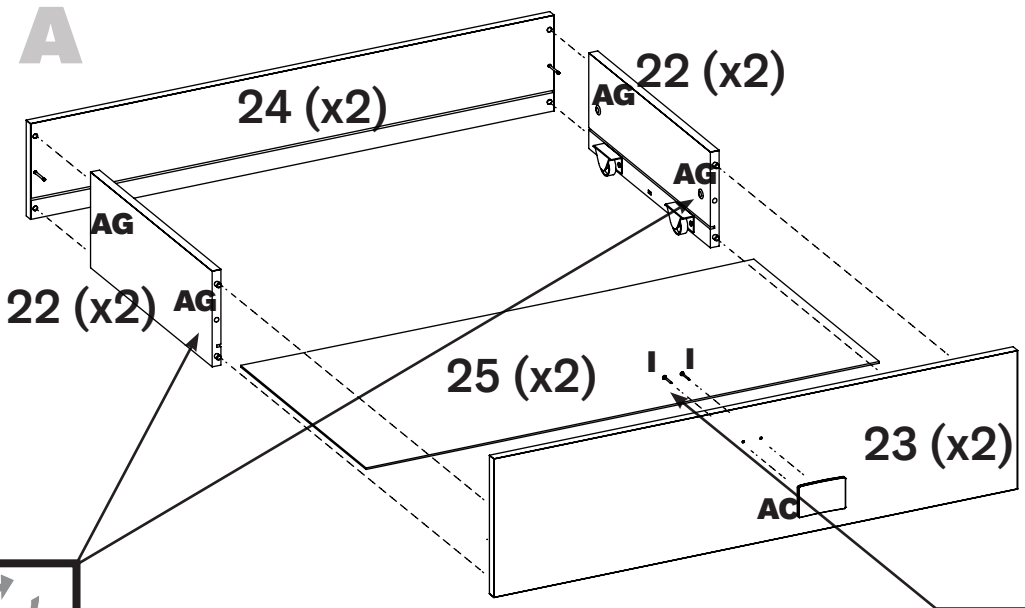

27

H x 08

V x 08

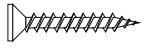

3.5 x 20 mm.

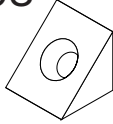

180°

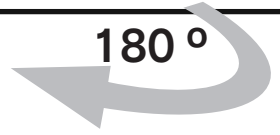

# Option A

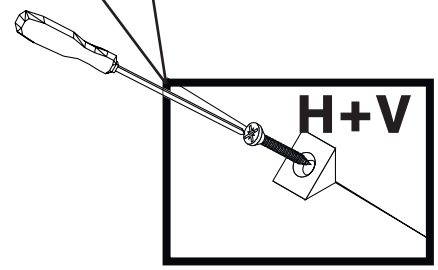
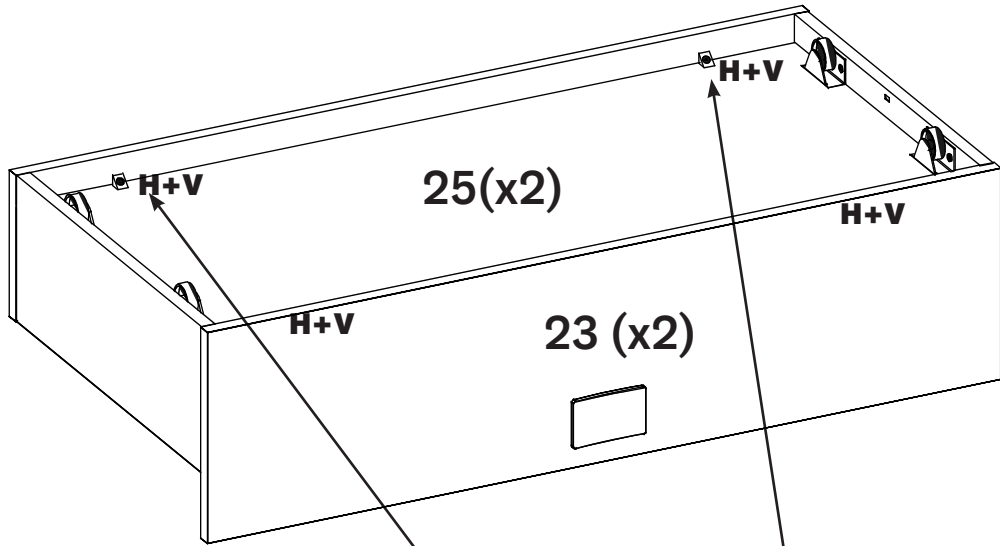

28

I x 02

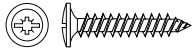

4 x 27 mm.

AC x 01

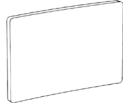

AI x 06



7 mm.

## Option A

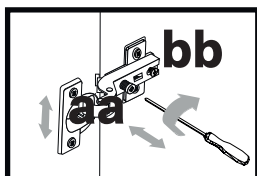
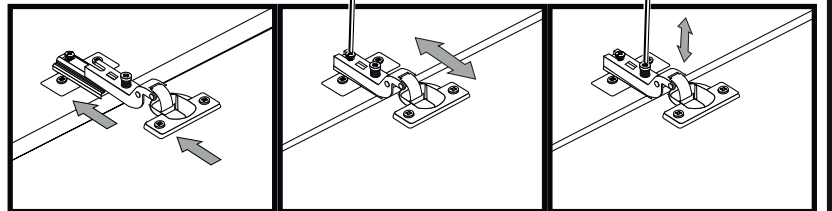
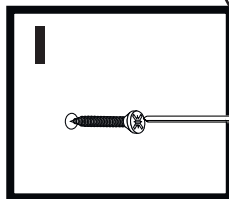
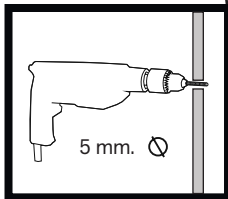
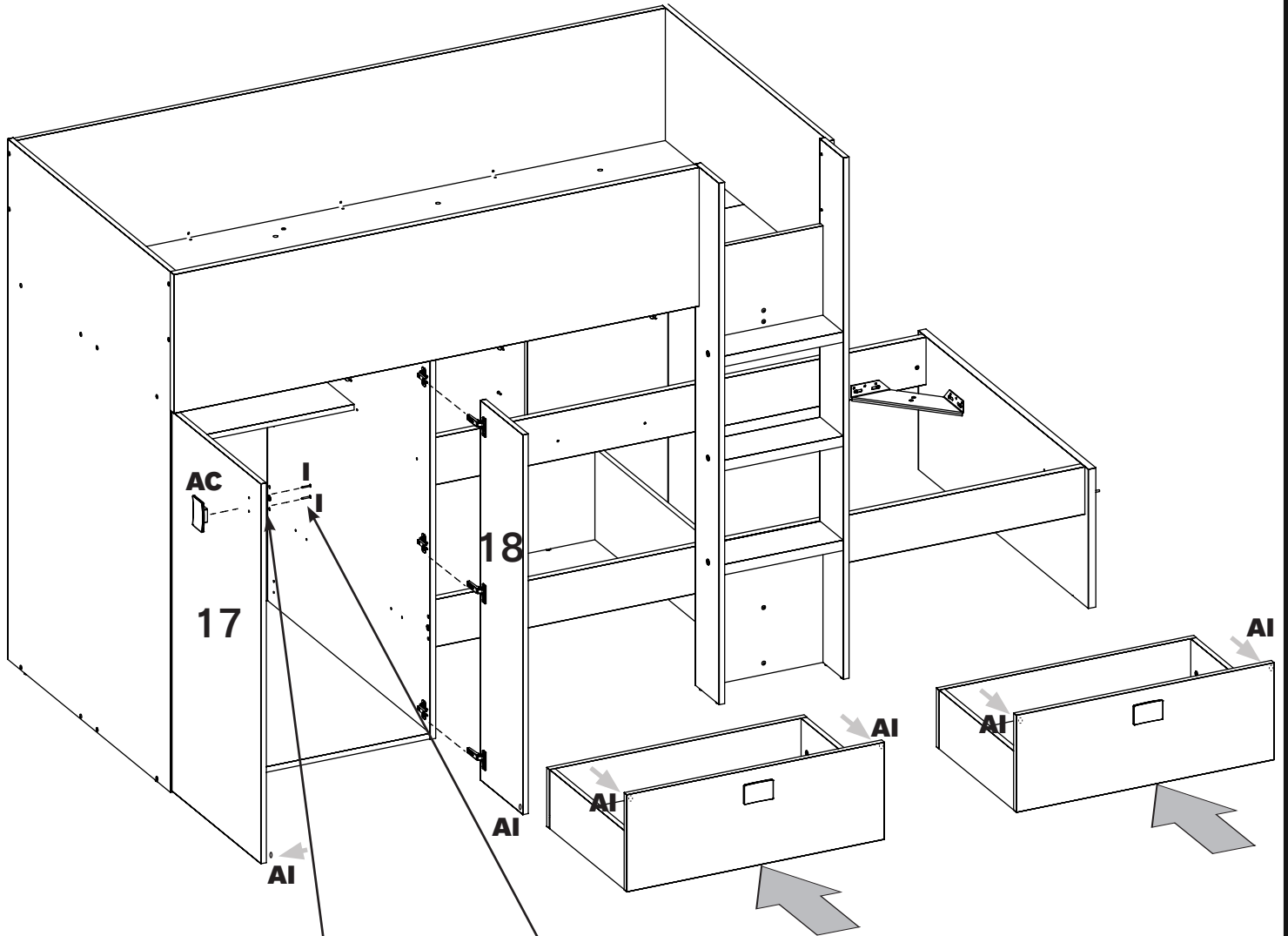
**EN**

Before to tighten the screw "aa", you have to slacken a little the screw "bb"

**ES**

Antes de apretar el tornillo "aa", hay que aflojar un poco el tornillo "bb"

**FR**

Avant de presser le vis "aa", il y a que relâcher un peu le vis "bb"

**PT**

Antes de apertar o parafuso "aa", deve desapertar um pouco o parafuso "bb"

**IT**

Prima di serrare la vite "aa", Allentare leggermente la vite "bb"

**DE**

Bevor die Schraube "aa" festgezogen wird lösen Sie ein wenig die schraub "bb"

# Option B

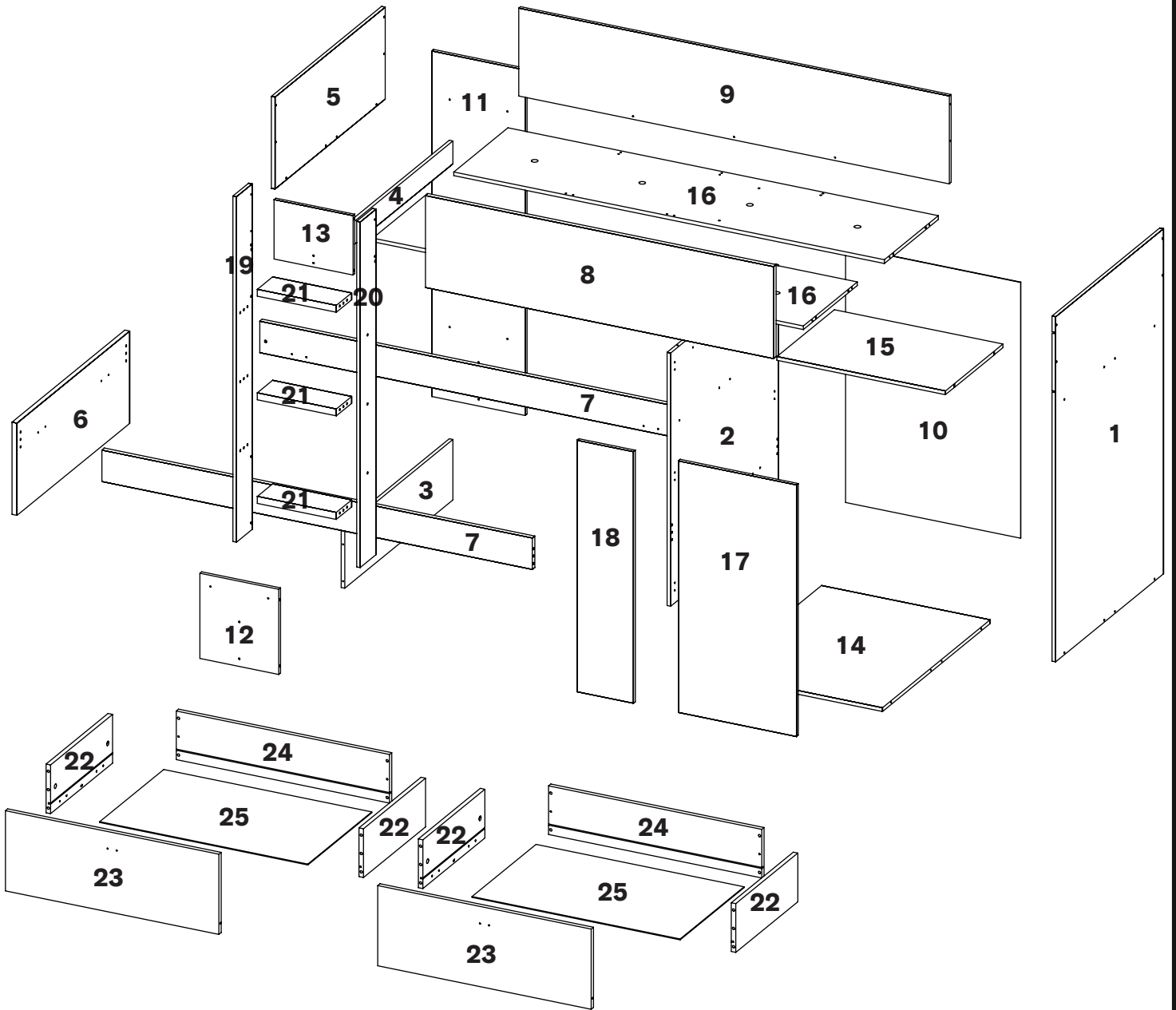



1

B x 03

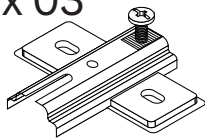

G x 08



3.5 x 15 mm.

R x 01

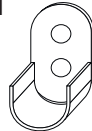

S x 04

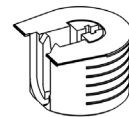

T x 02

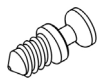

Z x 03



AH x 04



13 mm.

# Option B

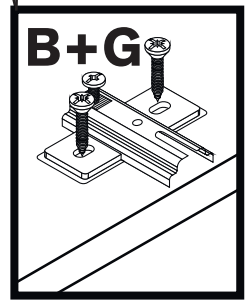
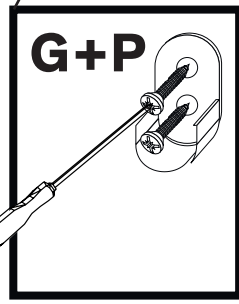
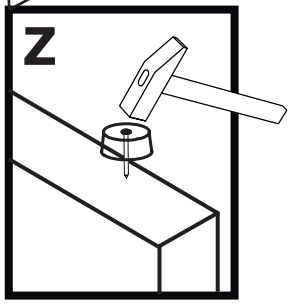
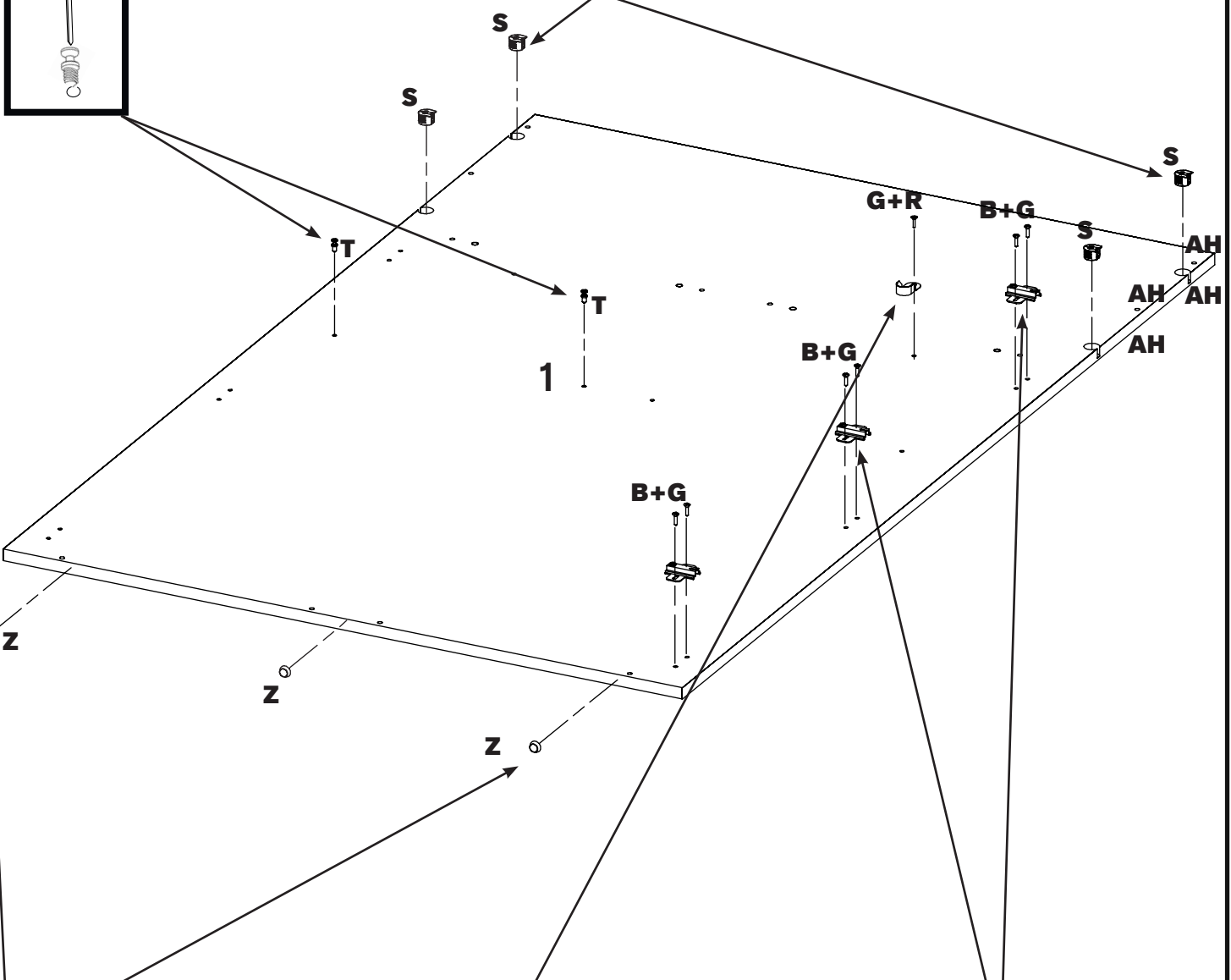
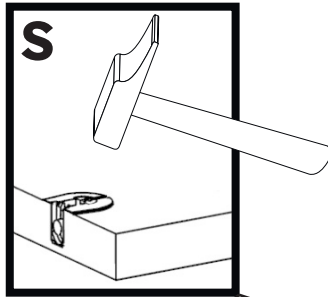
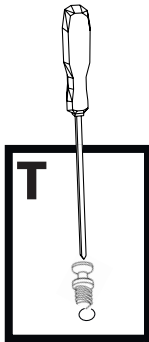

2

B x 03

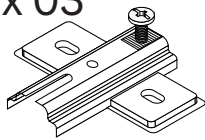

G x 08

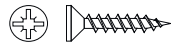

3.5 x 15 mm.

R x 01

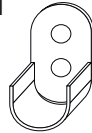

T x 02

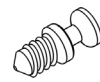

Z x 03

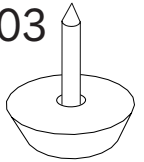

# Option B

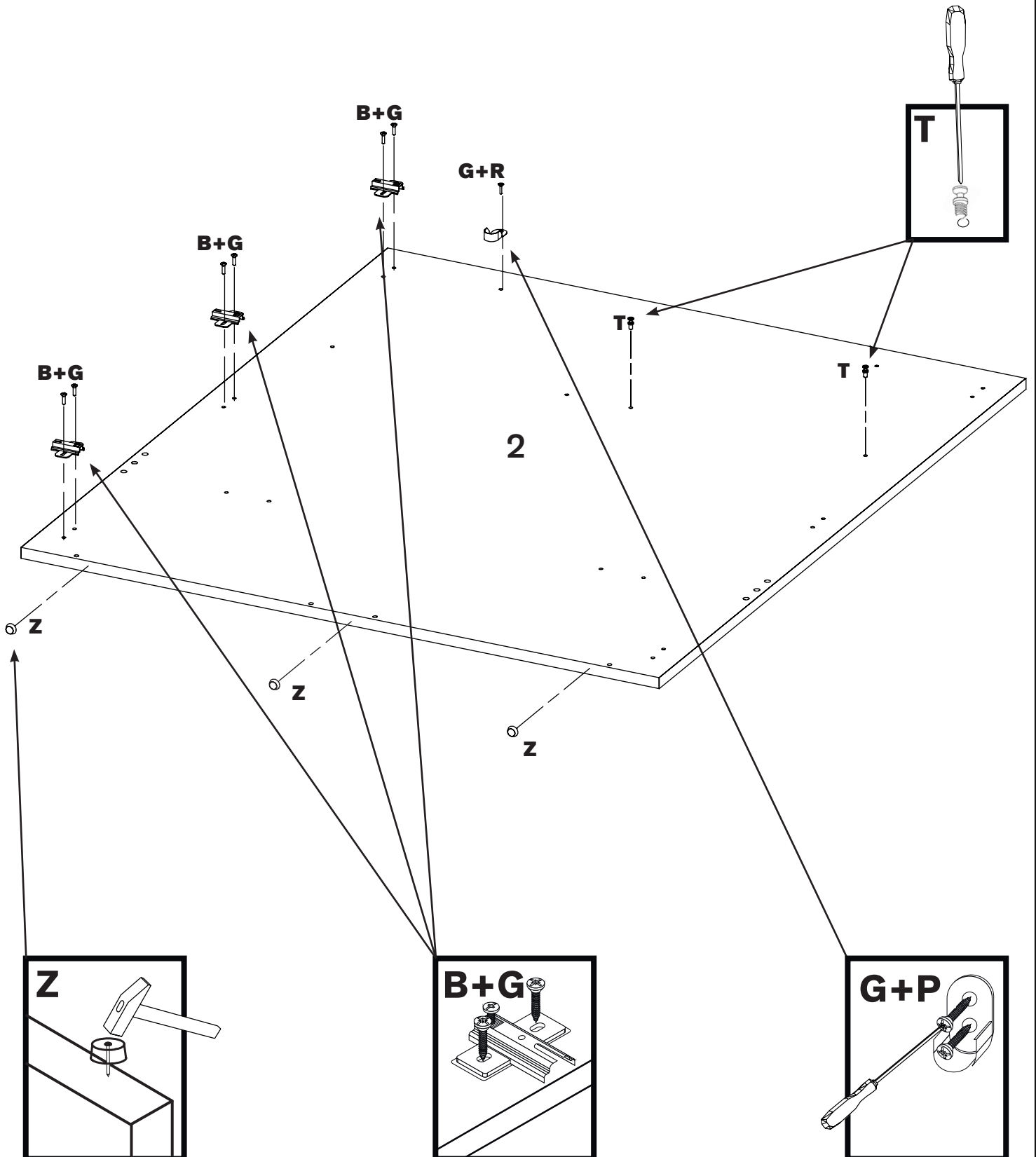

3 S x 04



### Option B

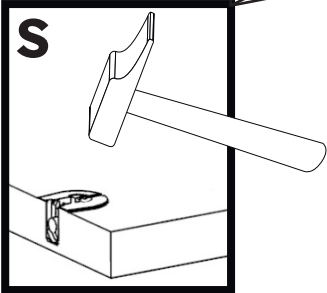
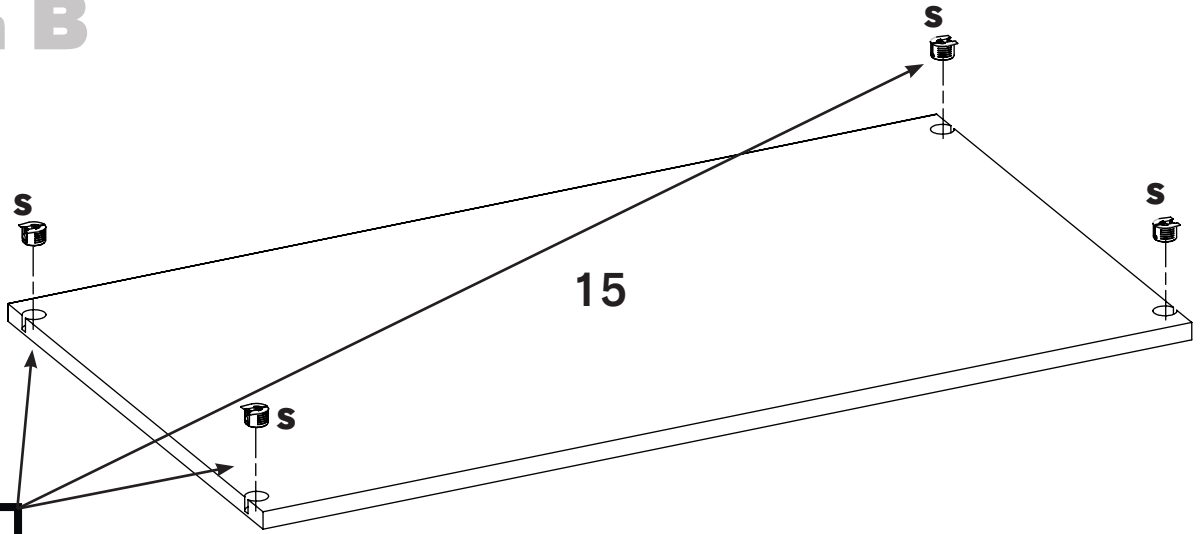

4 N x 08



5 x 50 mm.

AD x 01

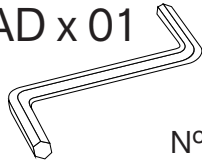

N° 3

AF x 08



3 mm.

### Option B

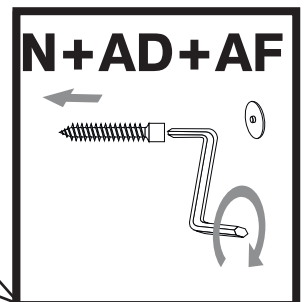
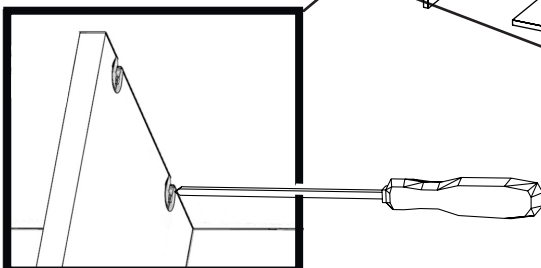
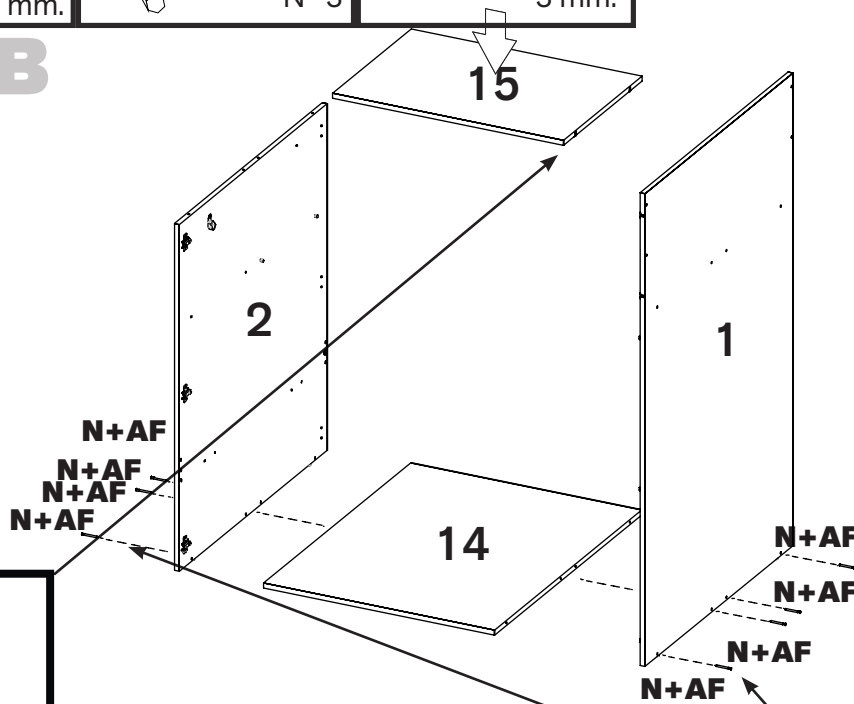

5 C x 04

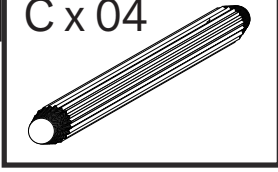

## Option B

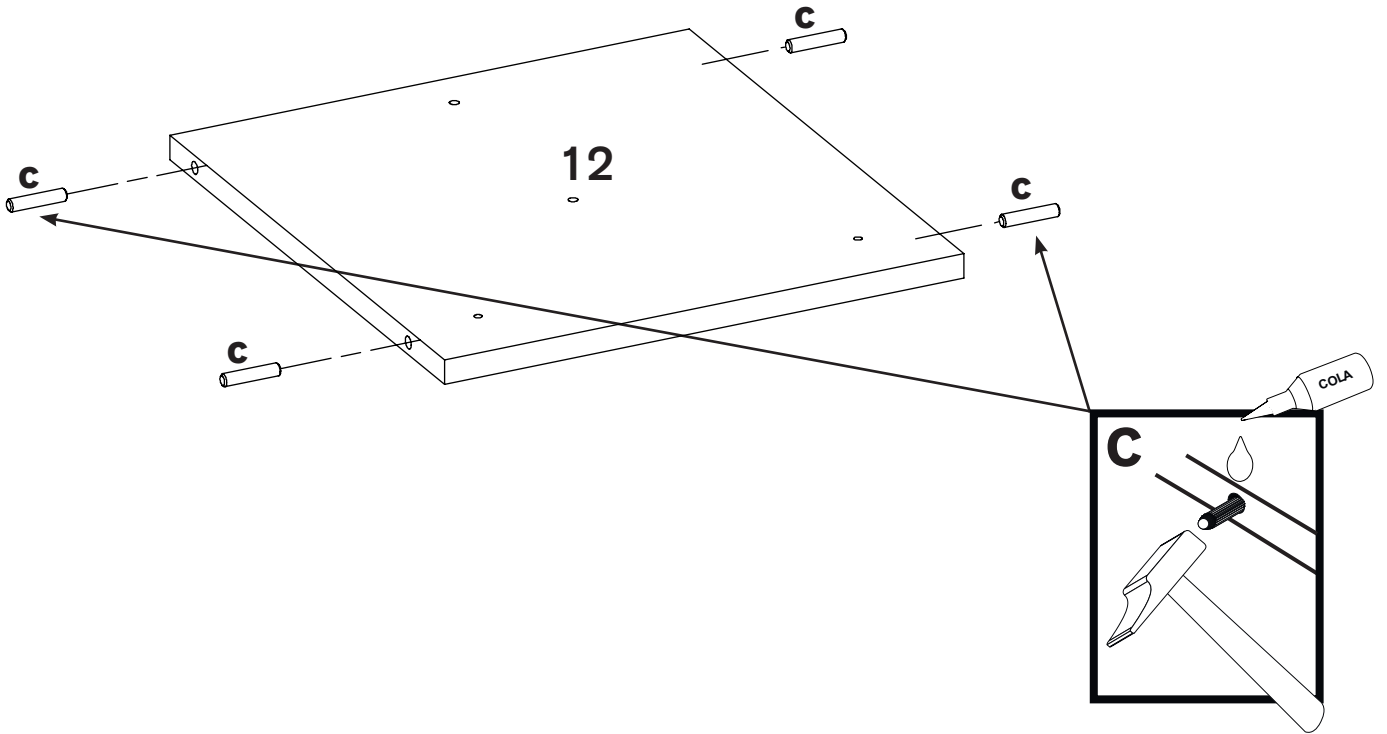

6 C x 04

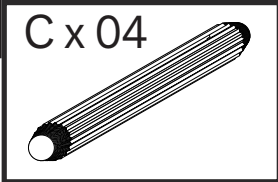

## Option B

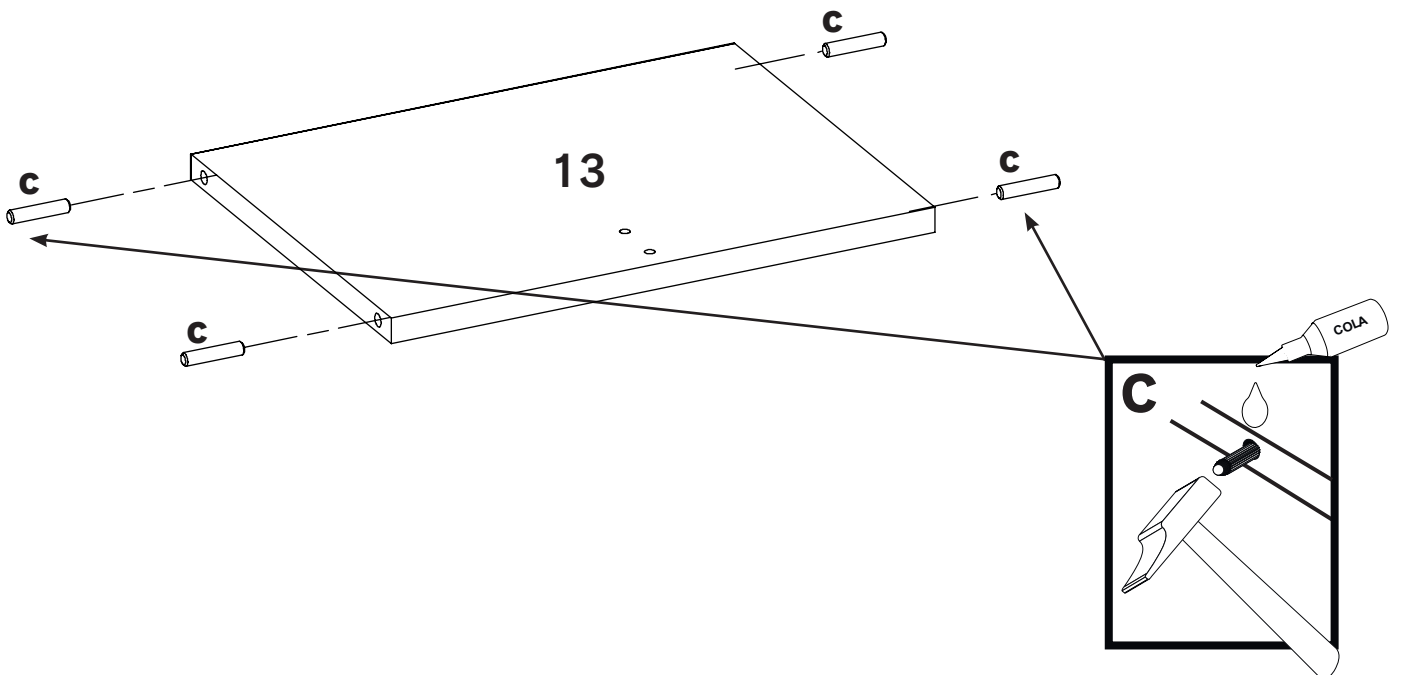

7

C x 12

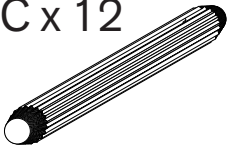

Q x 06



21 mm.

### Option B

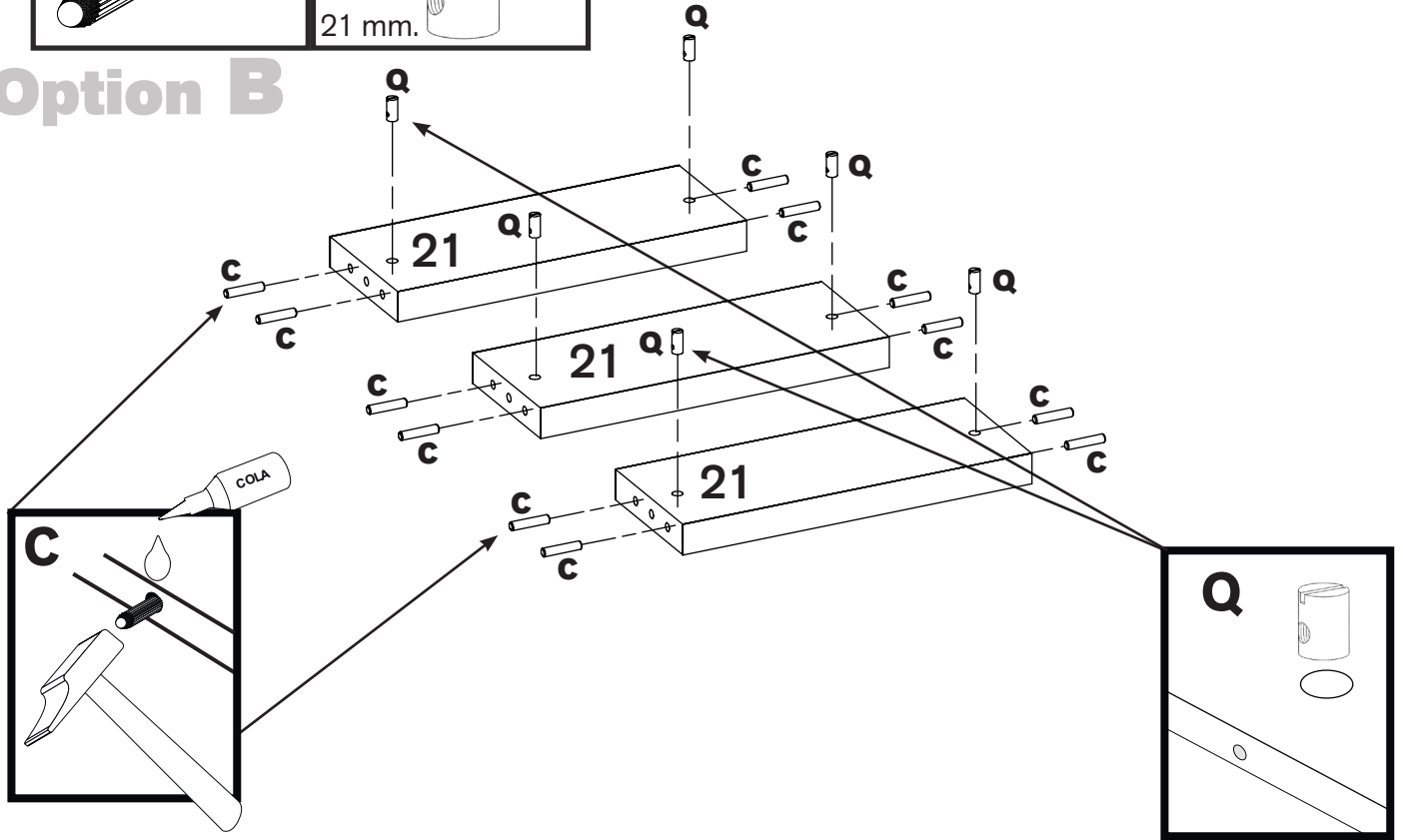

8

N x 02



5 x 50 mm.

O x 06

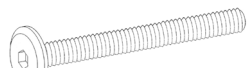

M6 x 60 mm.

Z x 02



AD x 01

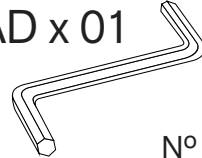

Nº 3

AE x 01

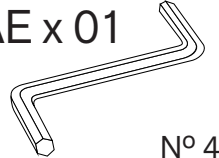

Nº 4

### Option B

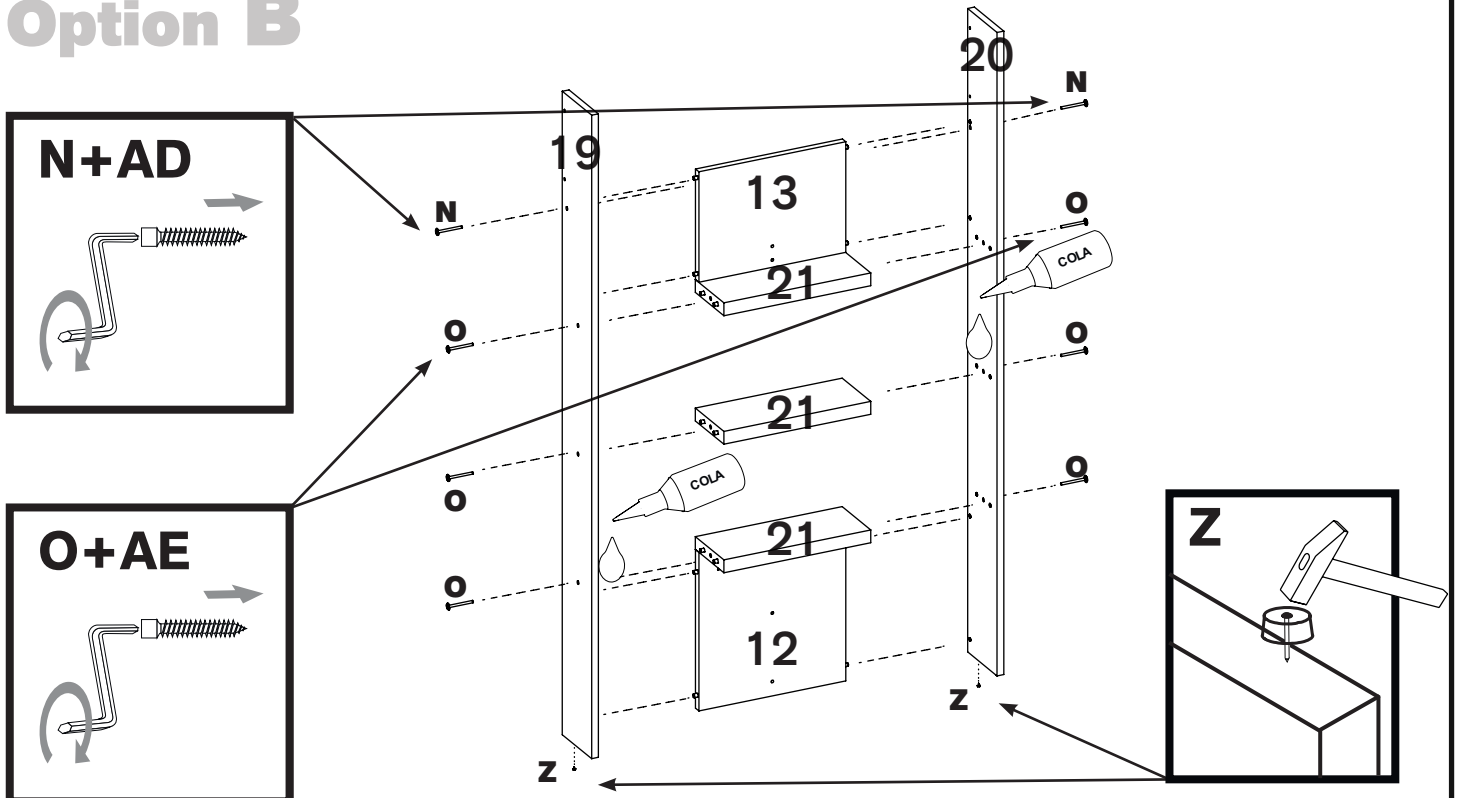

9

N x 08



5 x 50 mm.

Z x 04



AD x 01

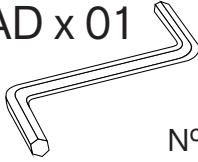

Nº 3

AH x 04



13 mm.

# Option B

N  
N

11

N

N

4

19

20

13

N+AH  
N+AH

3

Z

Z

Z

12

N+AH

N+AH

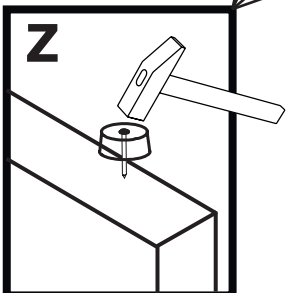

Z

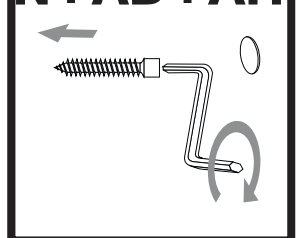

N+AD+AH

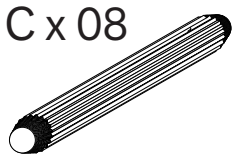

**10** C x 08      P x 04



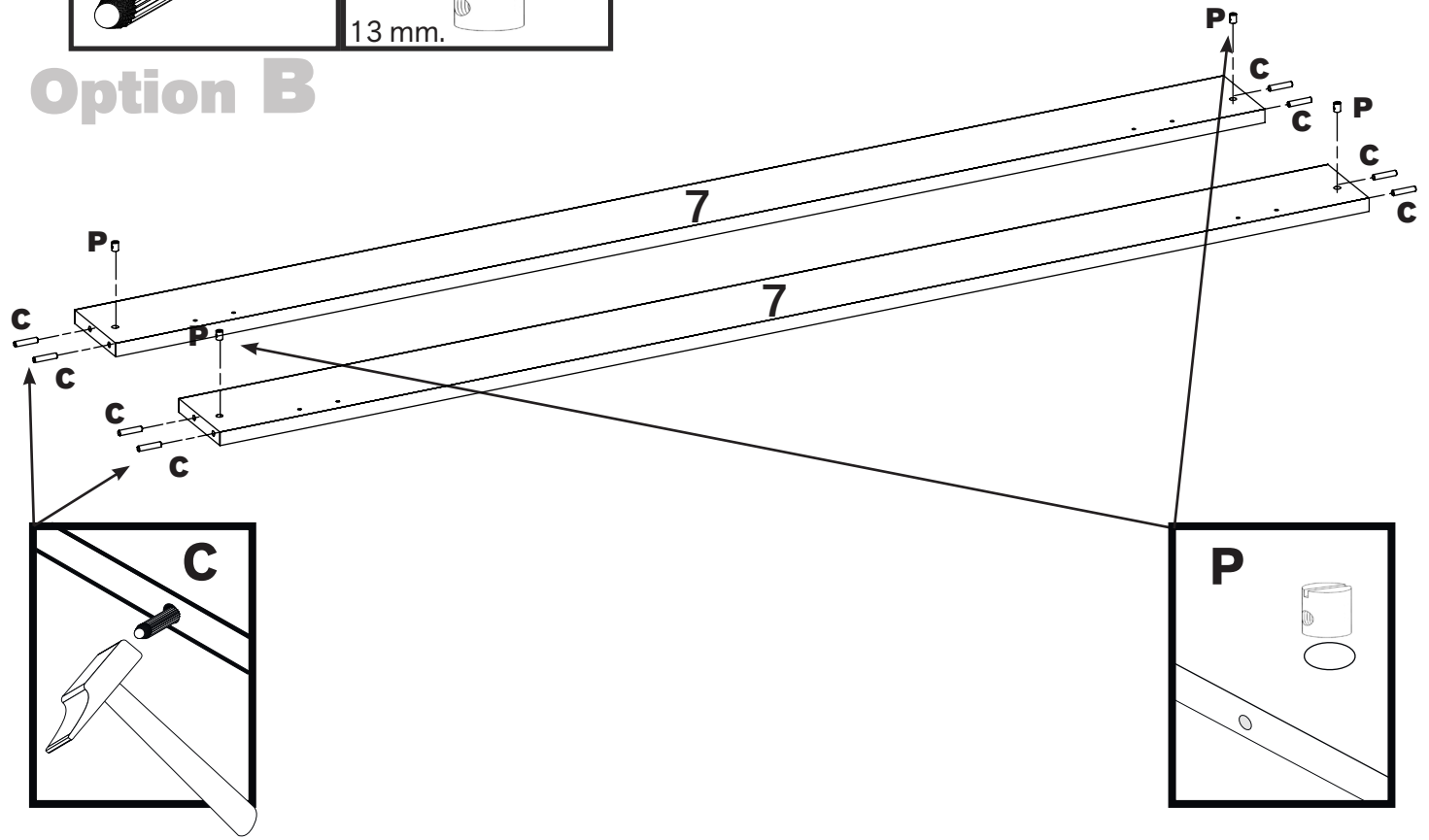

13 mm.

**Option B**



**11** O x 04      Z x 02      AE x 01

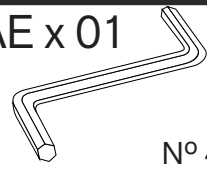

M6 x 60 mm.

N° 4

**Option B**



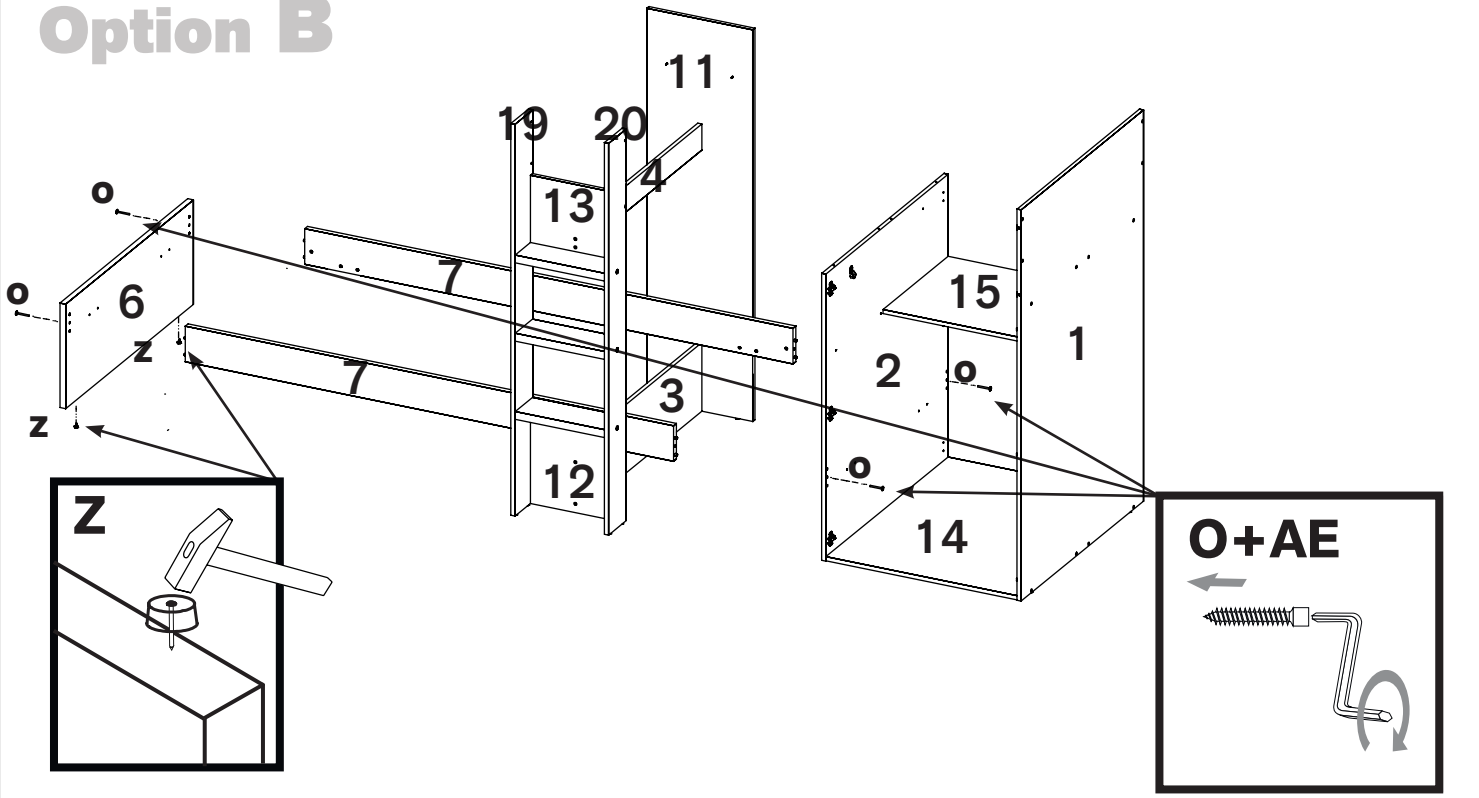

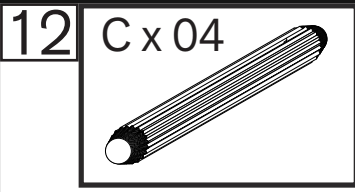
**Option B**

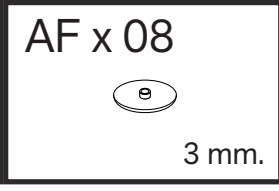
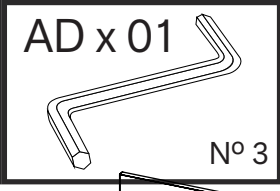
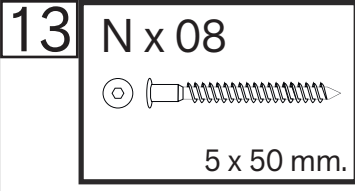
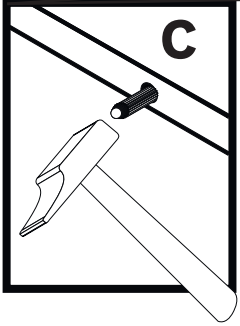
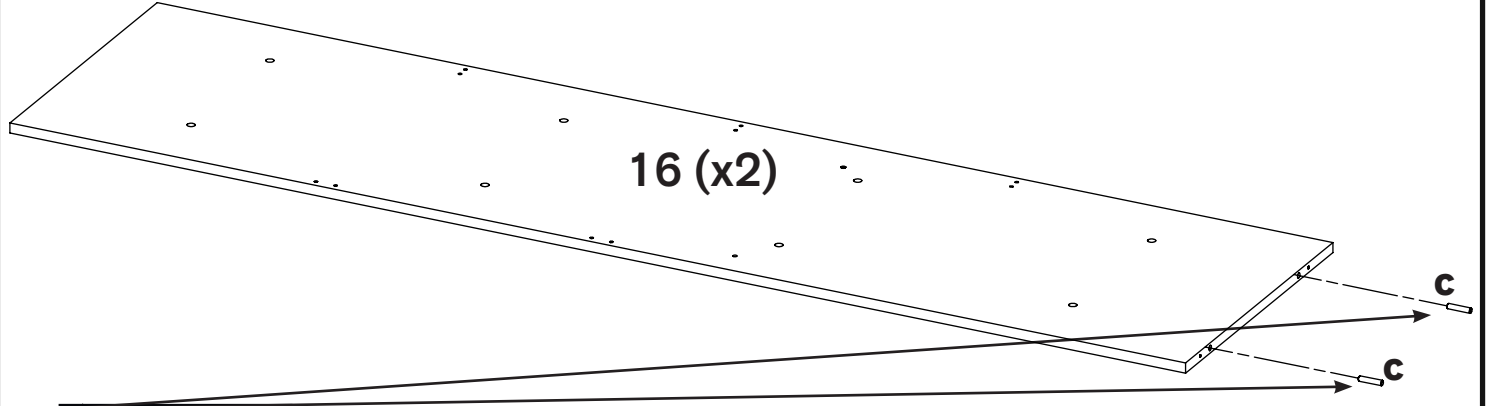

**Option B**

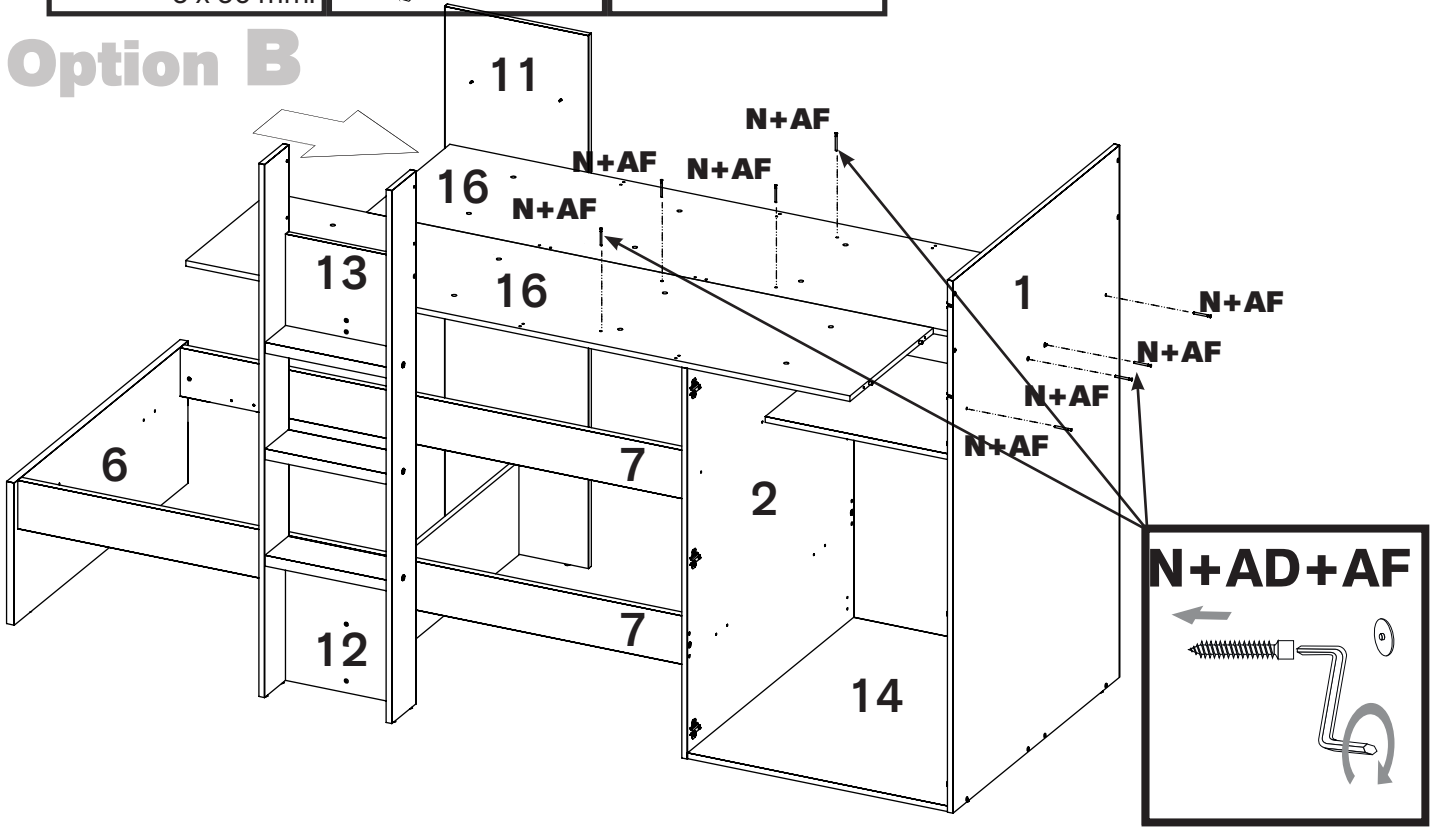

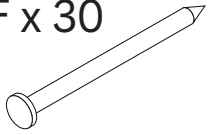
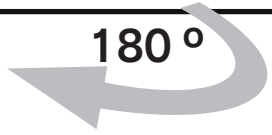

**14** F x 30

**Option B**

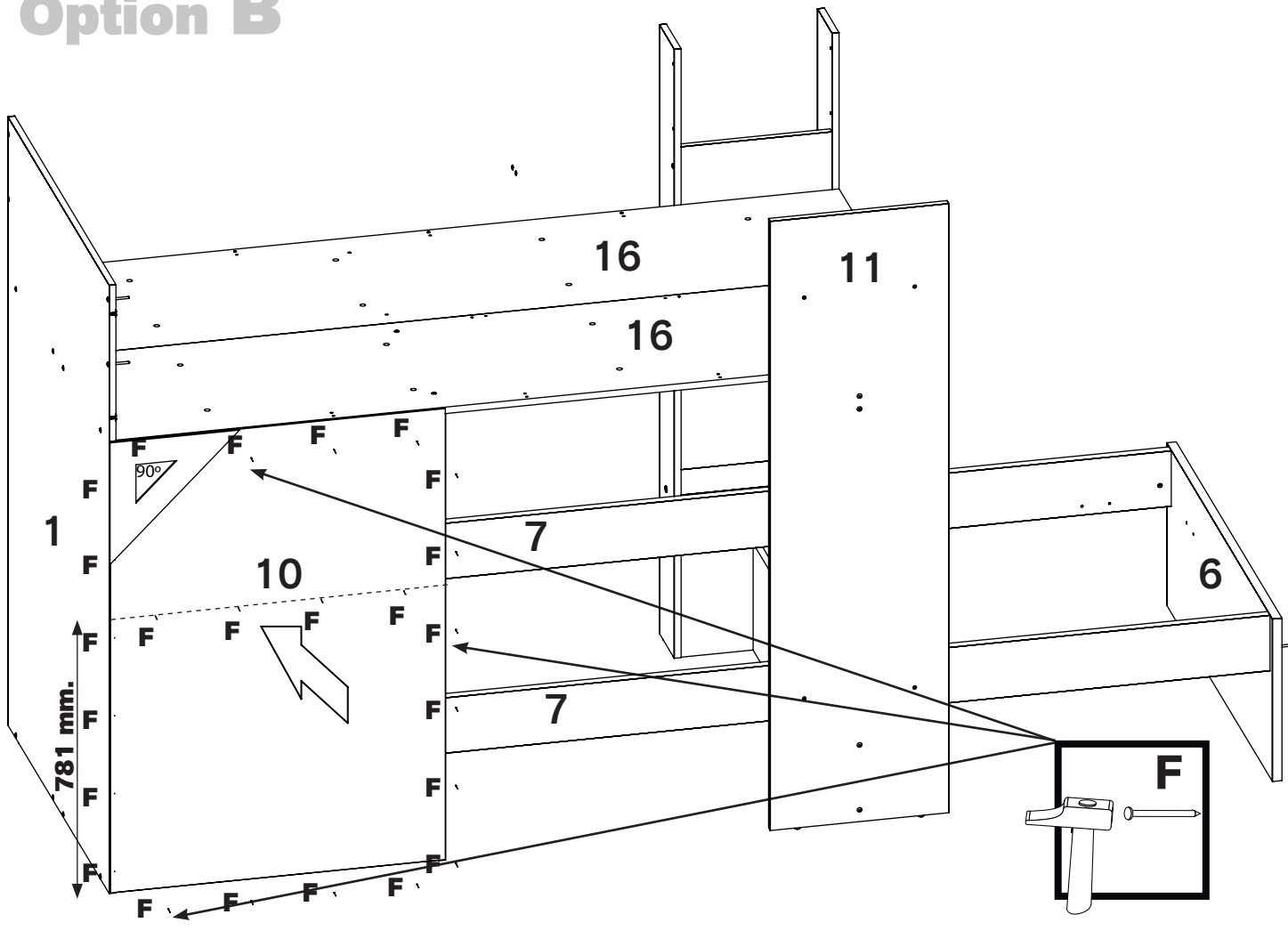

**15** J x 03

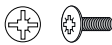

M4 x 10 mm.





K x 03

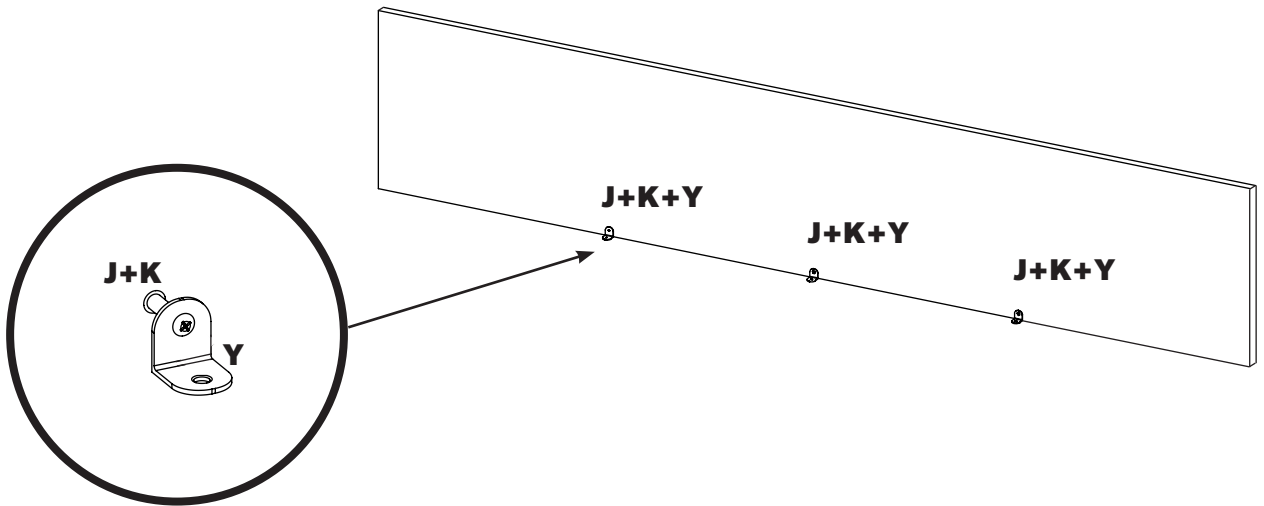

M4 x 15 mm.

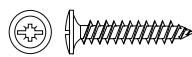
Y x 03

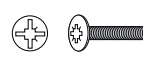

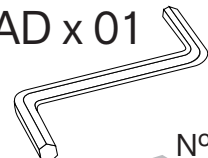



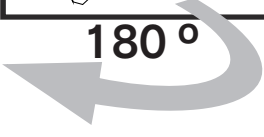

16	<b>I x 02</b>  4 x 27 mm.	<b>K x 02</b>  M4 x 15 mm.	<b>L x 02</b>  M4 x 25 mm.	<b>N x 08</b>  5 x 50 mm.	<b>AD x 01</b>  Nº 3
----	--	---	---	---	---

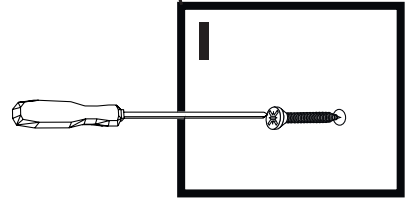
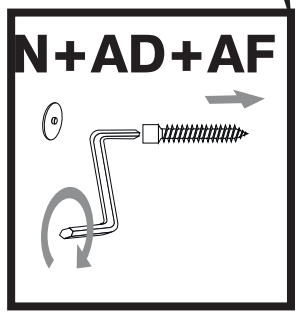
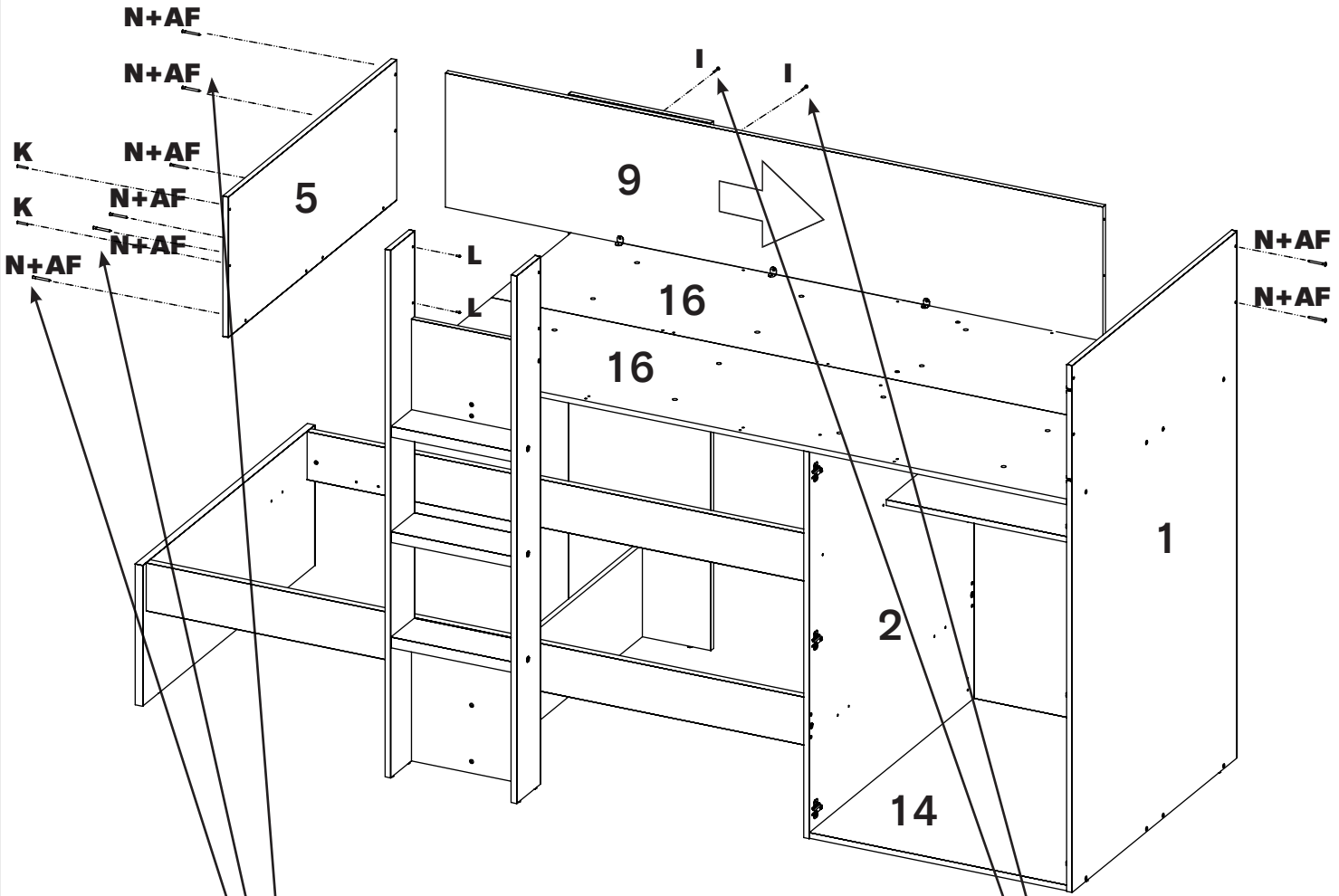
<b>AF x 08</b>  3 mm.
--

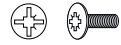

# Option B

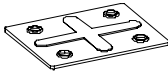

17	<b>G x 08</b>  3.5 x 15 mm.	<b>J x 03</b>  M4 x 10 mm.	<b>K x 03</b>  M4 x 15 mm.	<b>AB x 02</b> 	<b>AH x 08</b>  13 mm.
----	--	---	---	---	---

# Option B

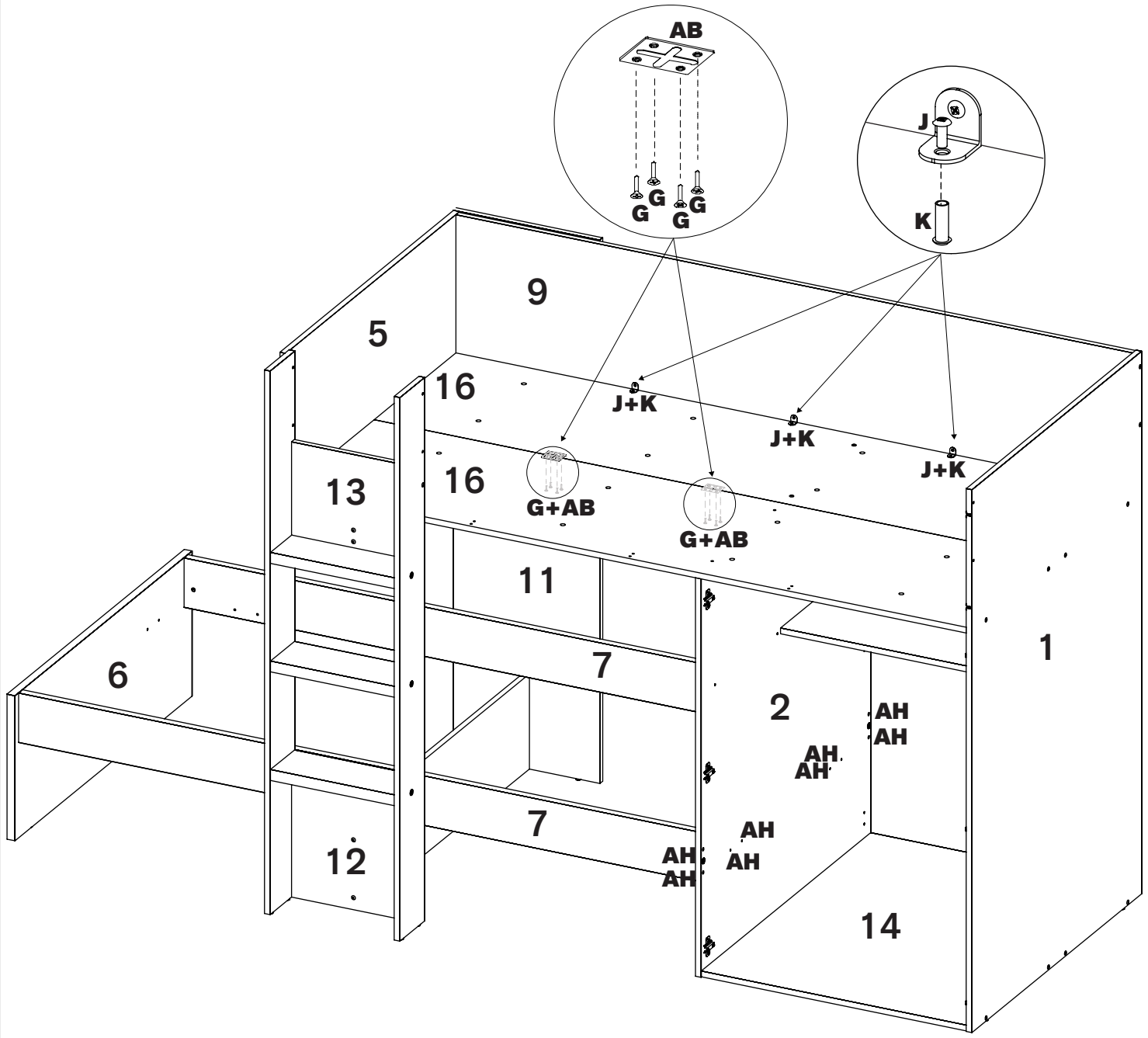

18

G x 05



3.5 x 15 mm.

T x 02



Y x 05



# Option B

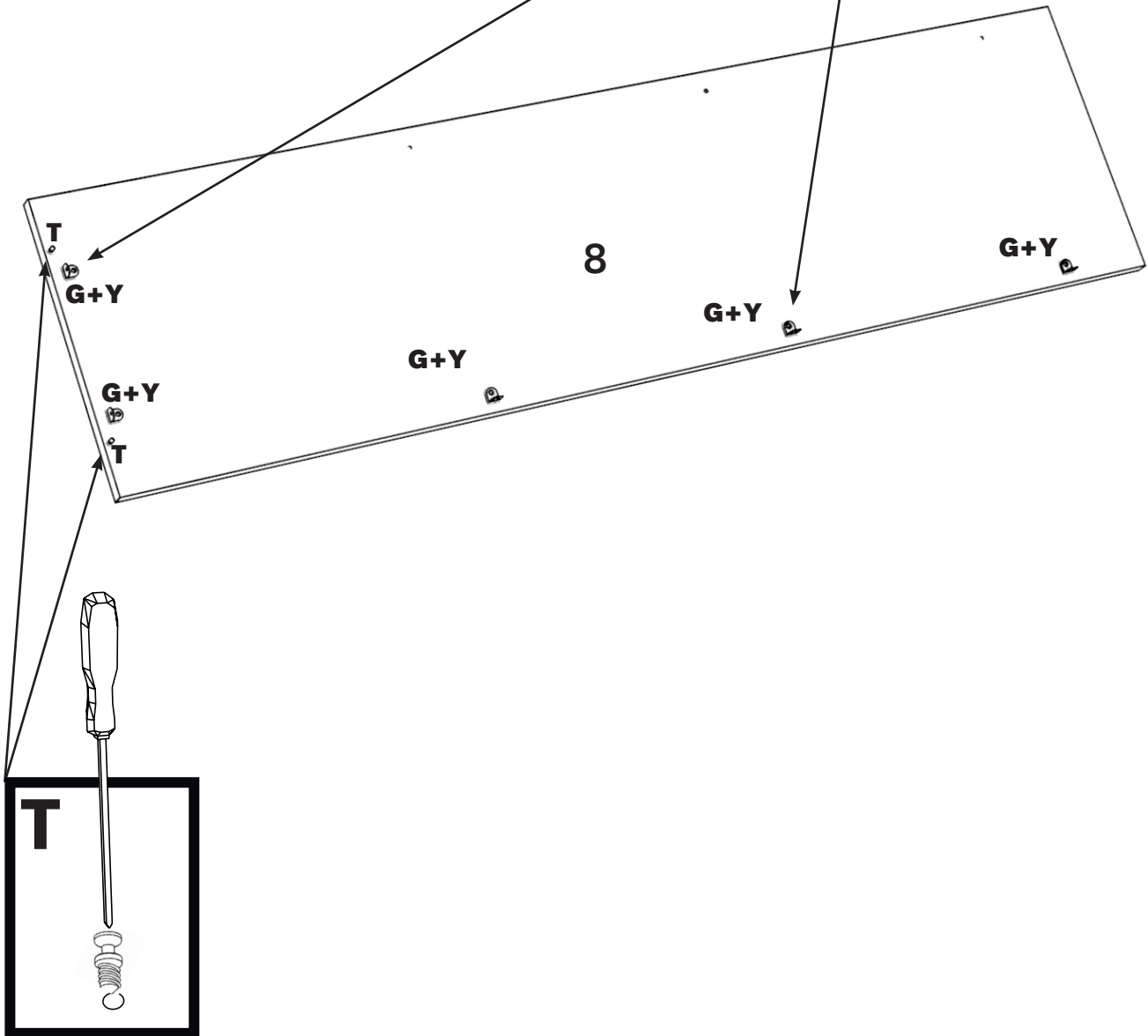
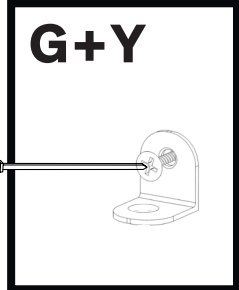

19

G x 02



3.5 x 15 mm.

J x 03



M4 x 10 mm.

K x 03



M4 x 15 mm.

N x 02



5 x 50 mm.

AD x 01

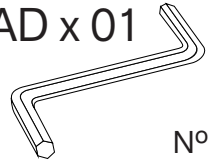

Nº 3

AH x 02



13 mm.

# Option B

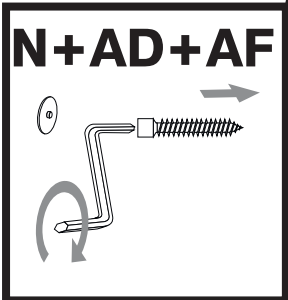
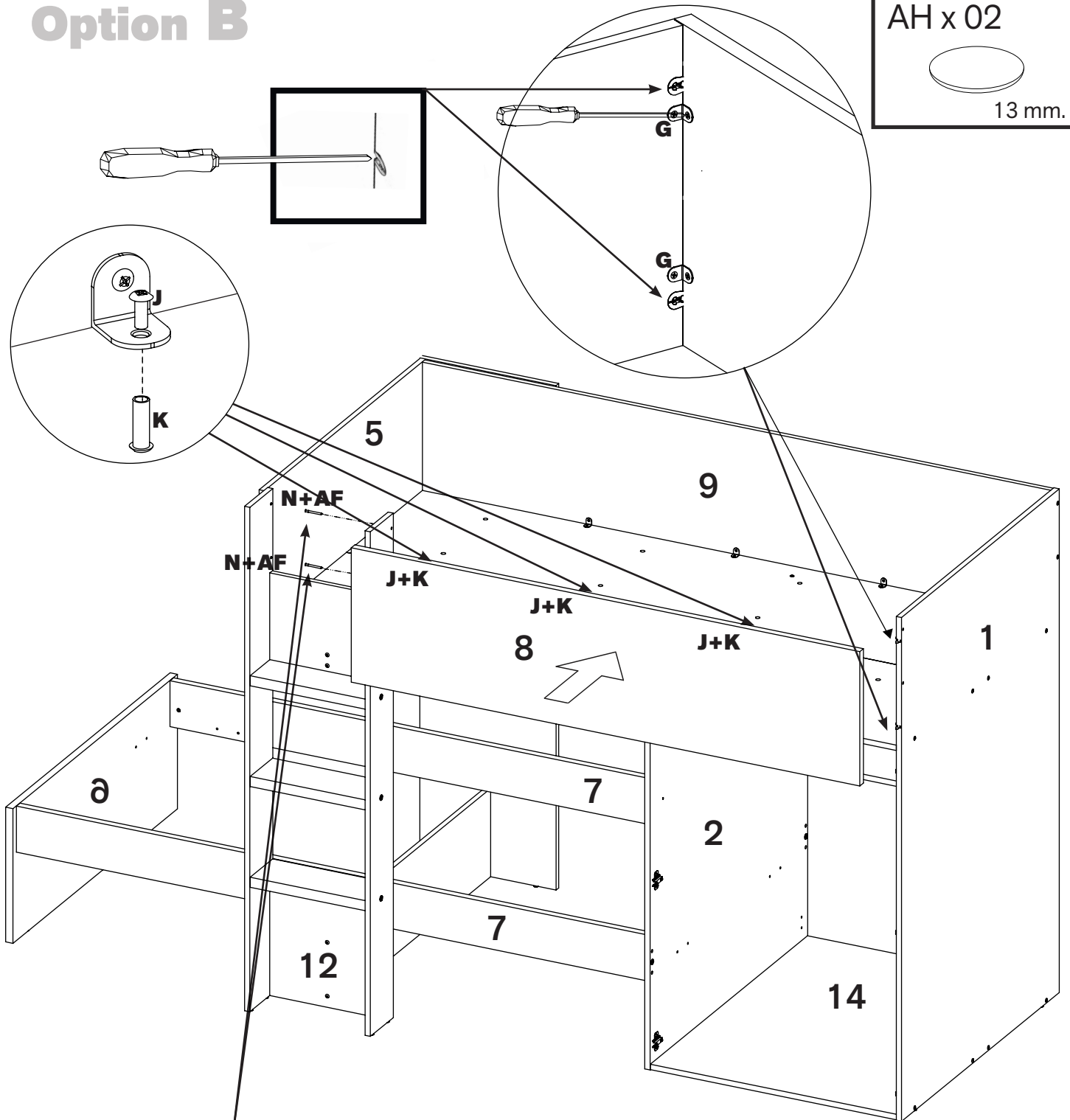

20

G x 24

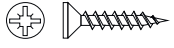

3.5 x 15 mm.

M x 04

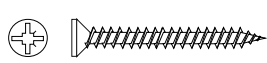

3.5 x 30 mm.

Ñ x 16

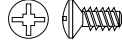

6.3 x 14 mm.

U x 04

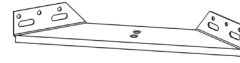

AH x 02



13 mm.

# Option B

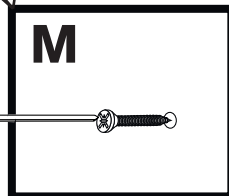
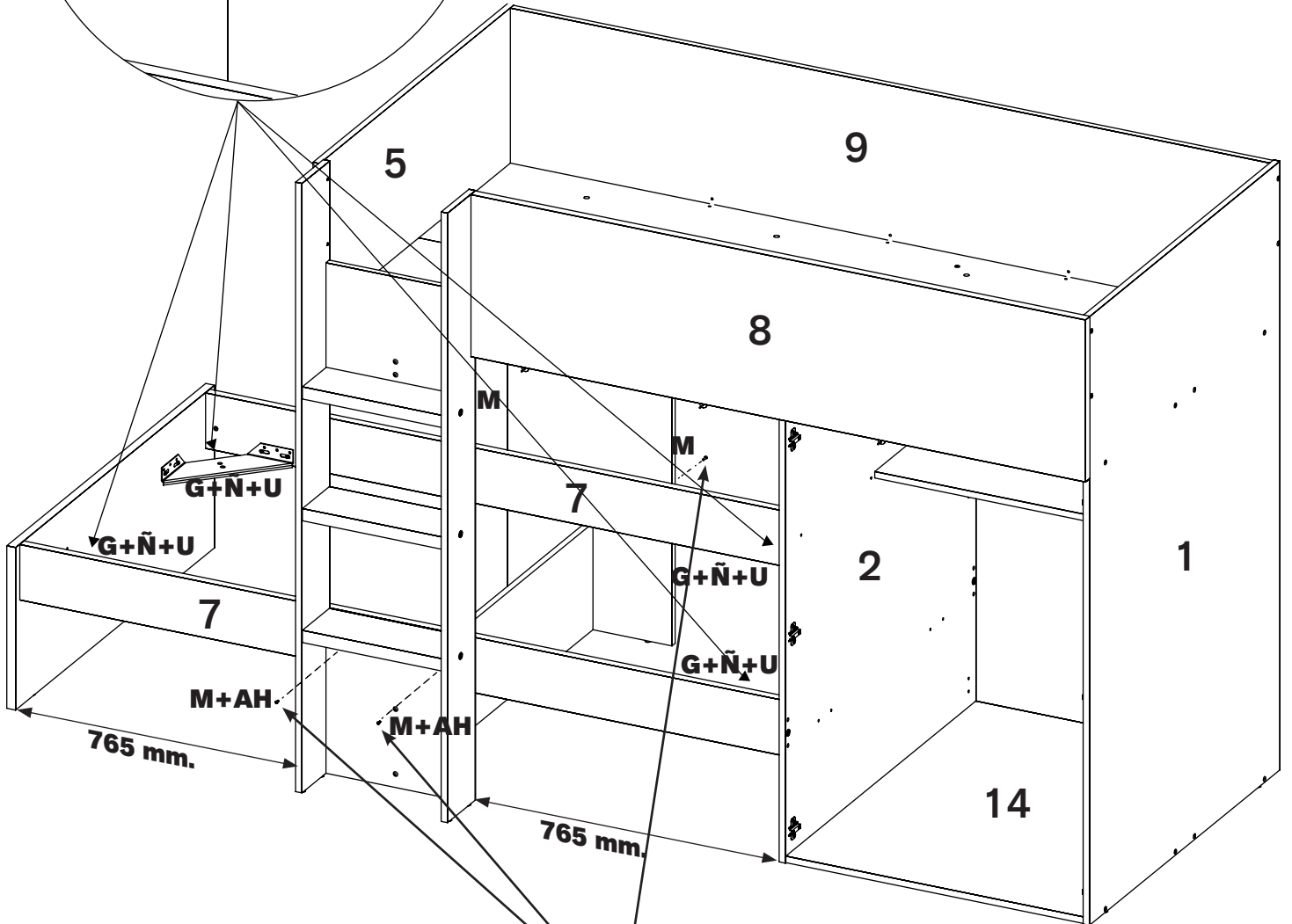
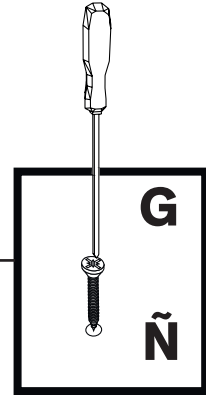
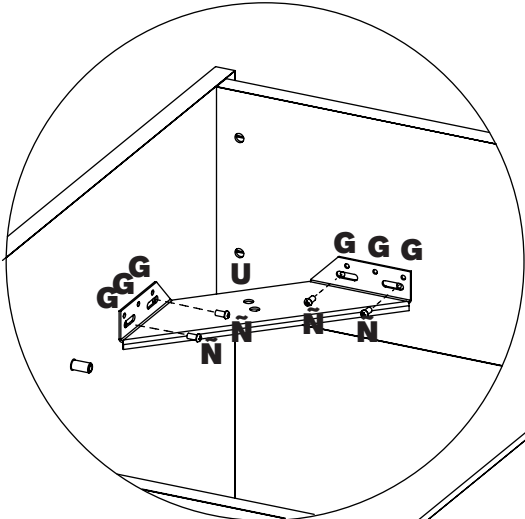

21

A x 03

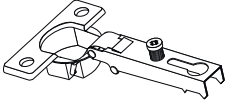

G x 06



3.5 x 15 mm.

# Option B

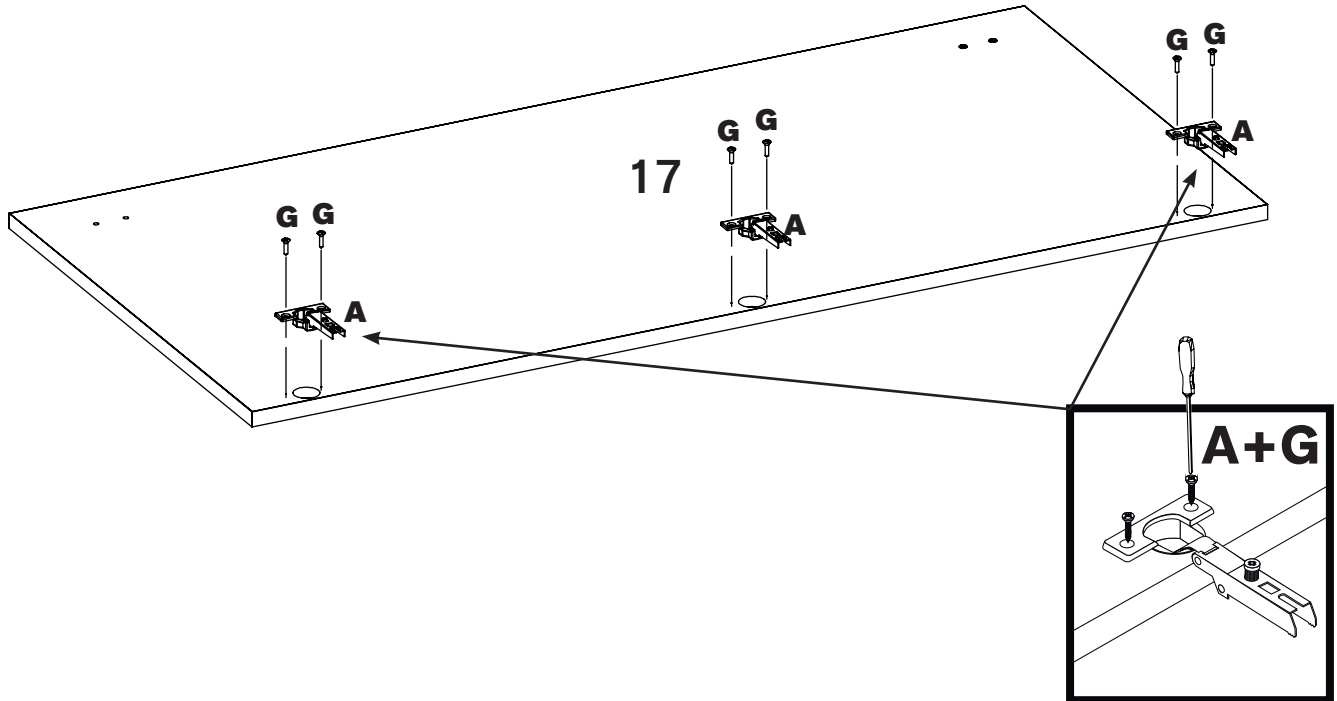

22

A x 03

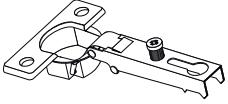

G x 06



3.5 x 15 mm.

# Option B

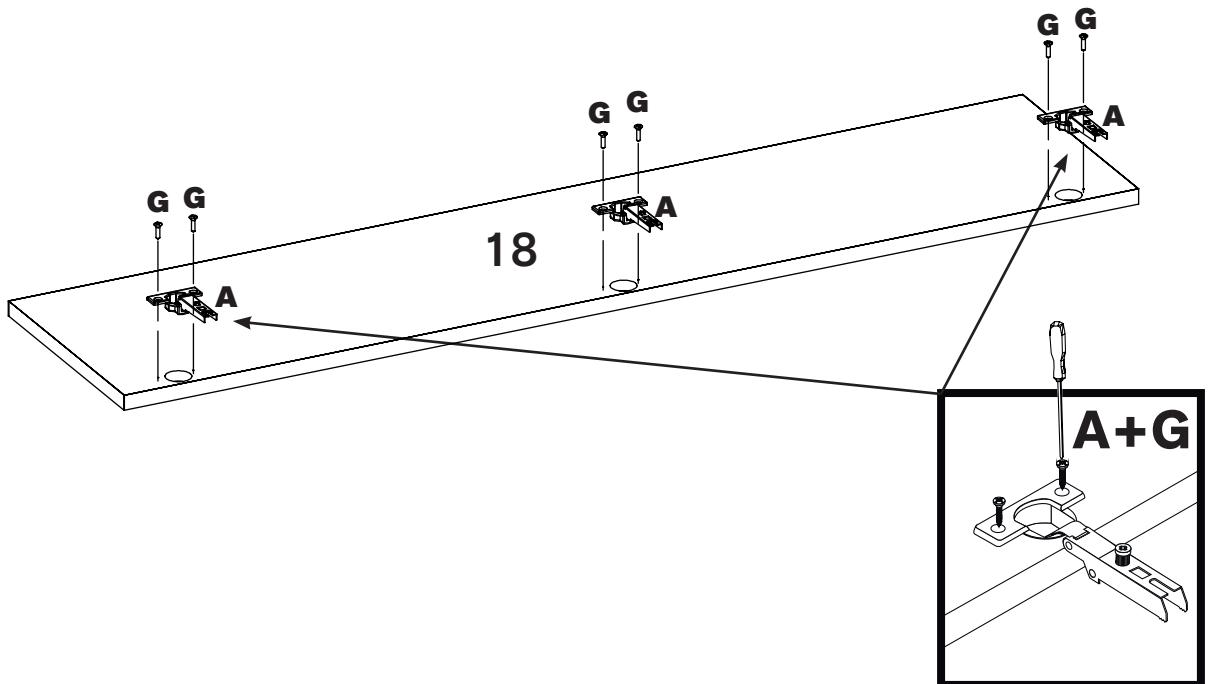

23

C x 16

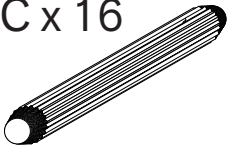

E x 08

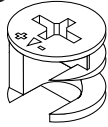

G x 16

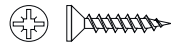

3.5 x 15 mm.

W x 08

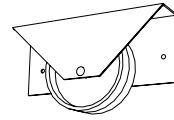

### Option B

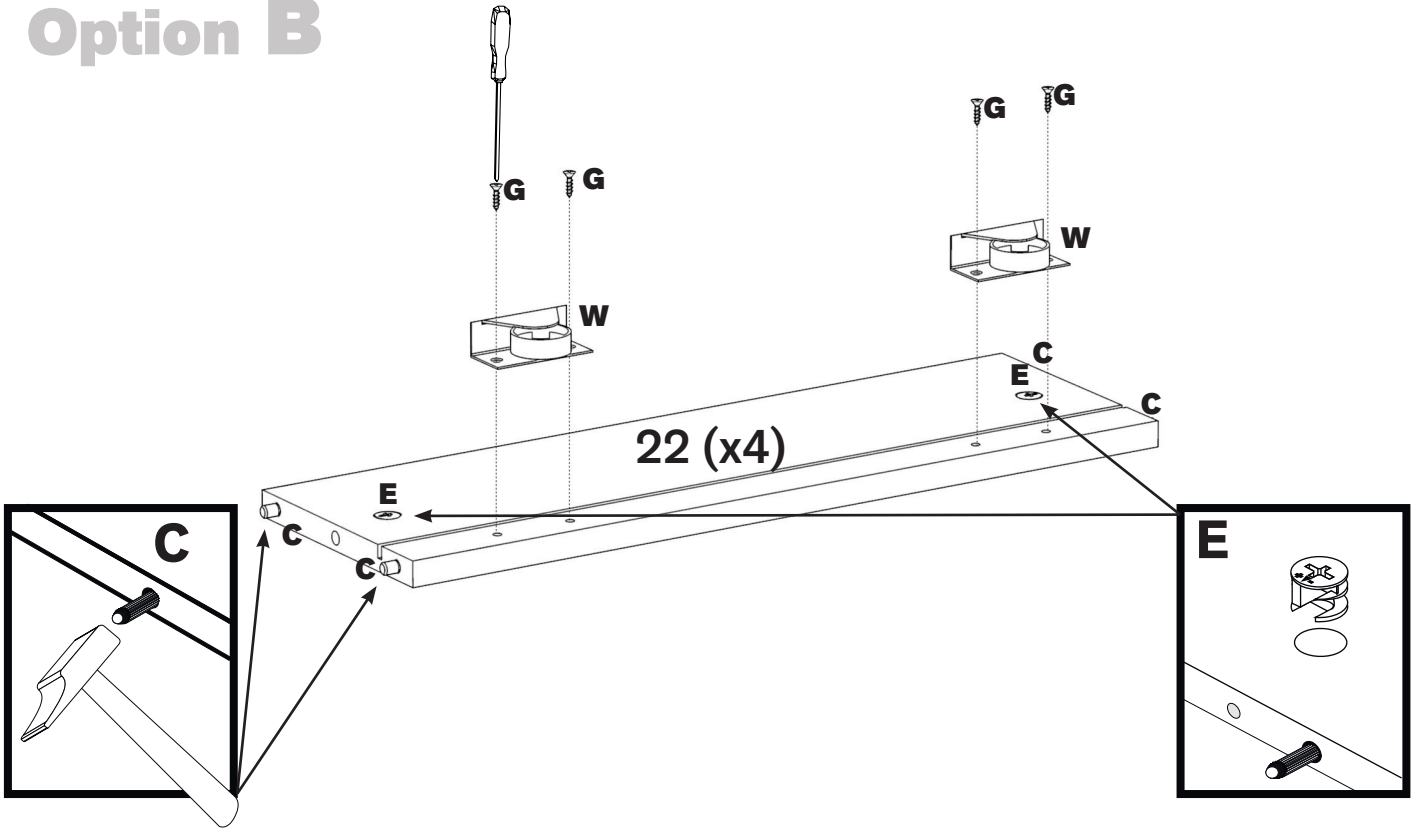

24

D x 04

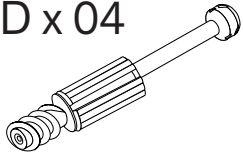

### Option B

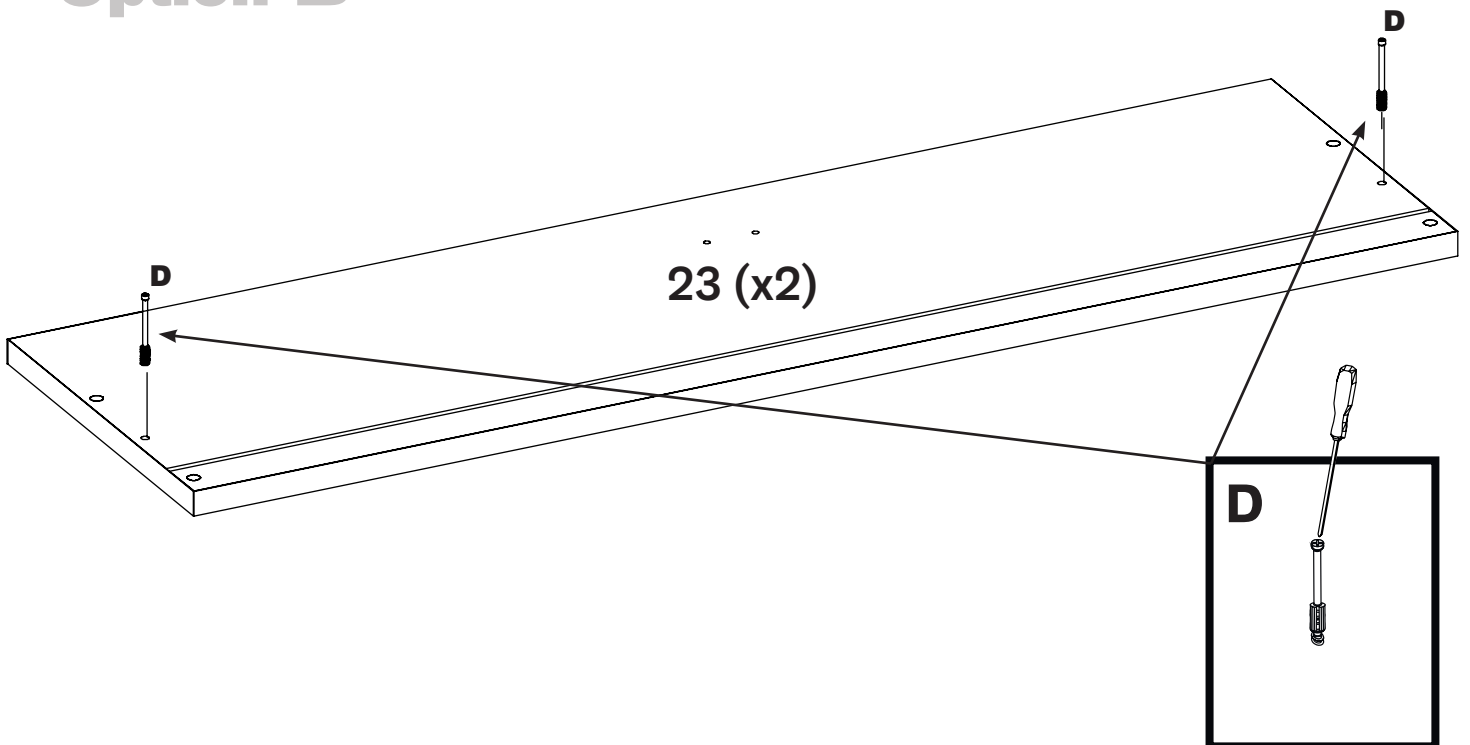



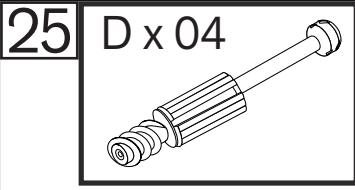

**Option B**

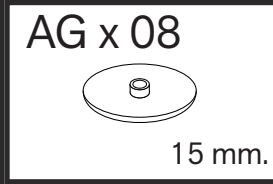
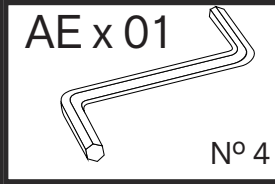
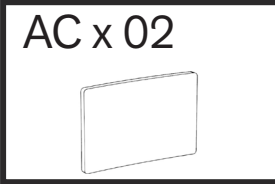
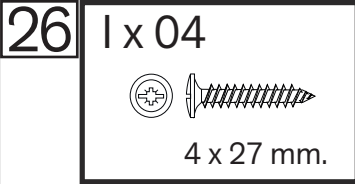
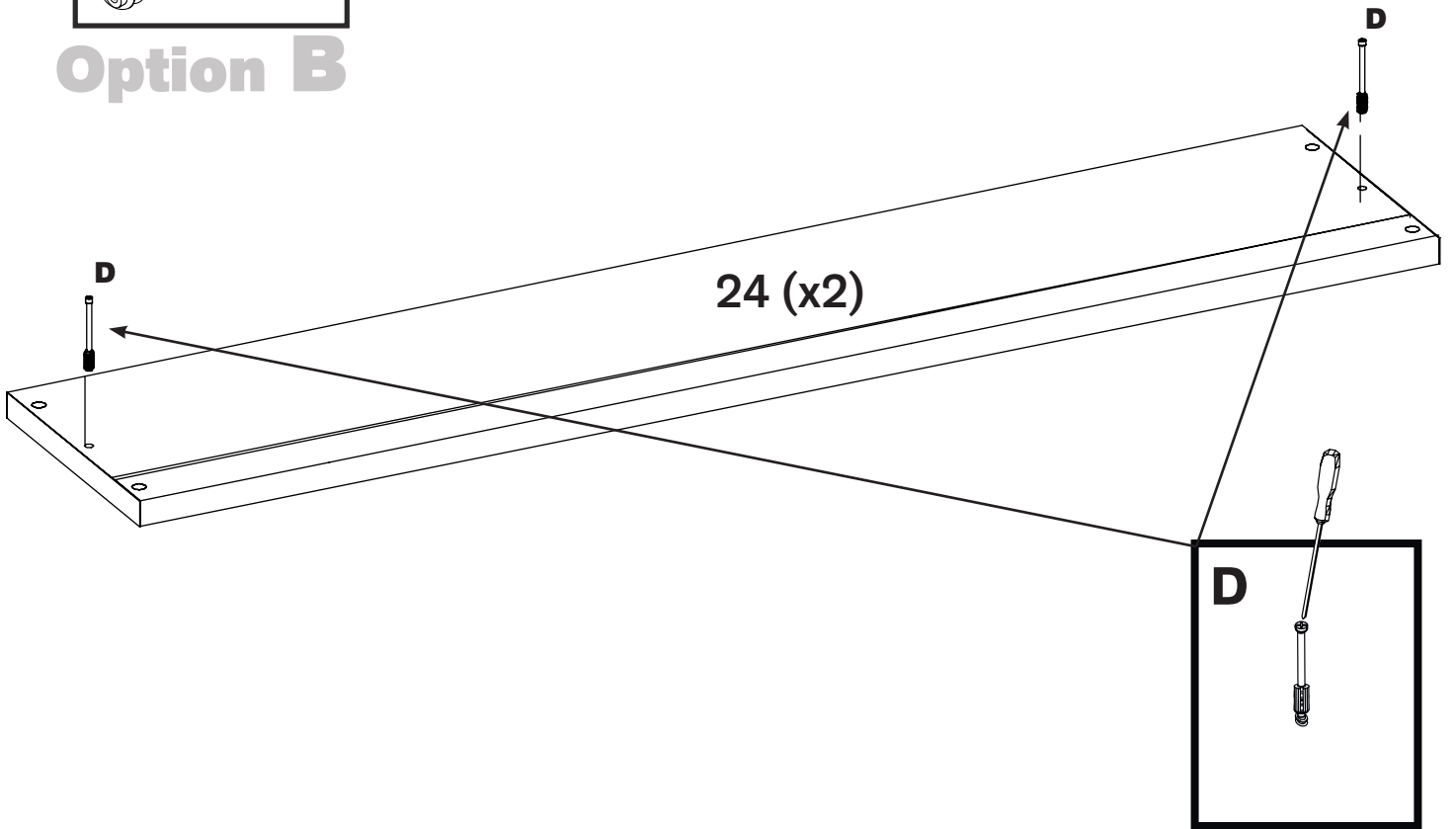

**Option B**

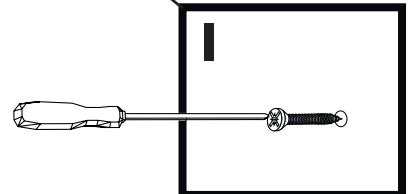
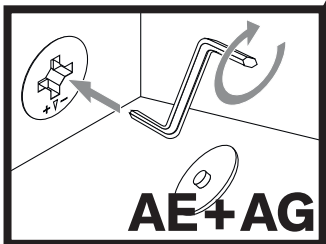
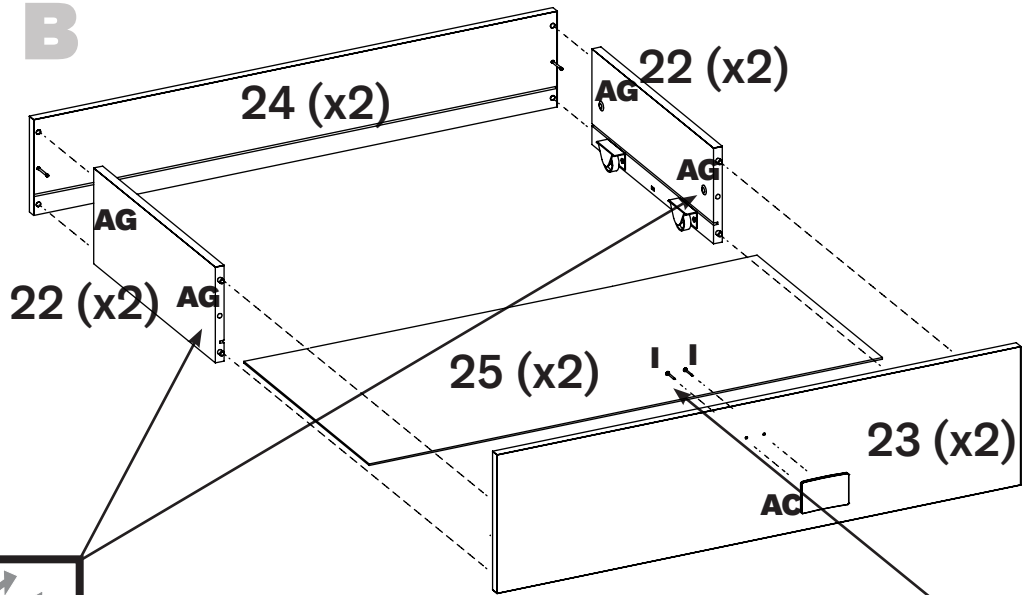

27

H x 08

V x 08

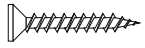

3.5 x 20 mm.

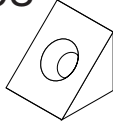

180°

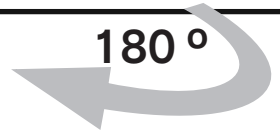

# Option B

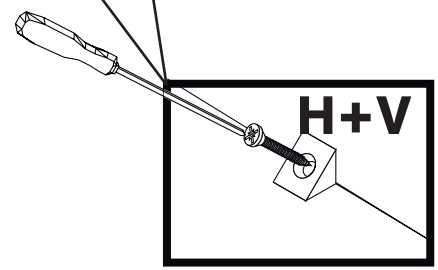
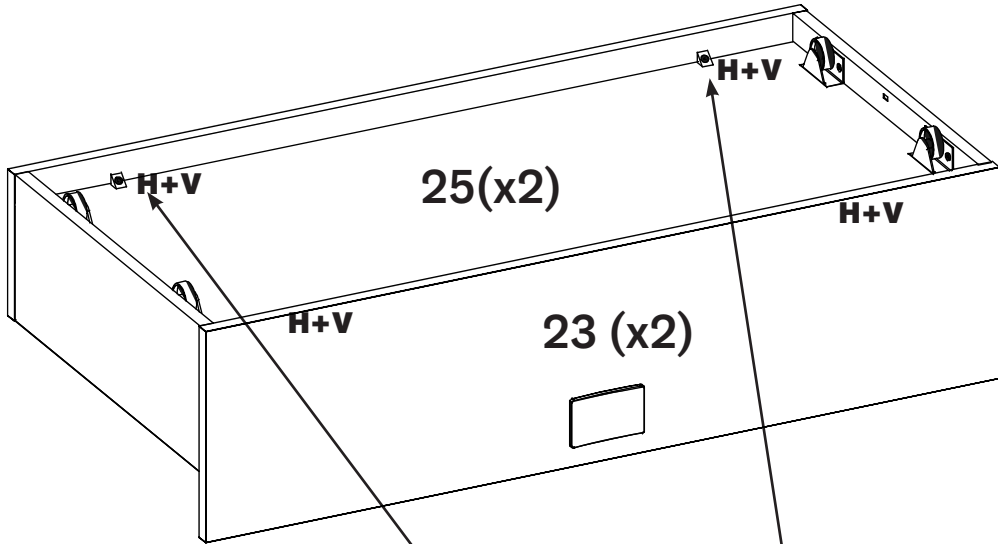

28

I x 02

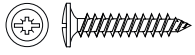

4 x 27 mm.

AC x 01

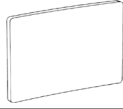

AI x 06



7 mm.

# Option B

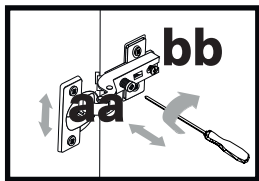
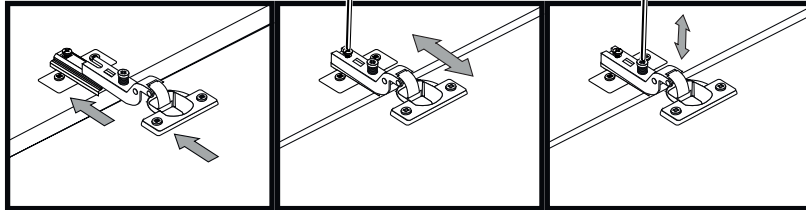
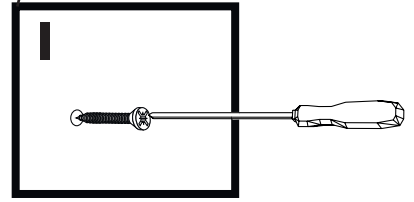
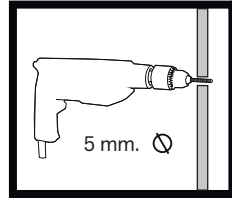
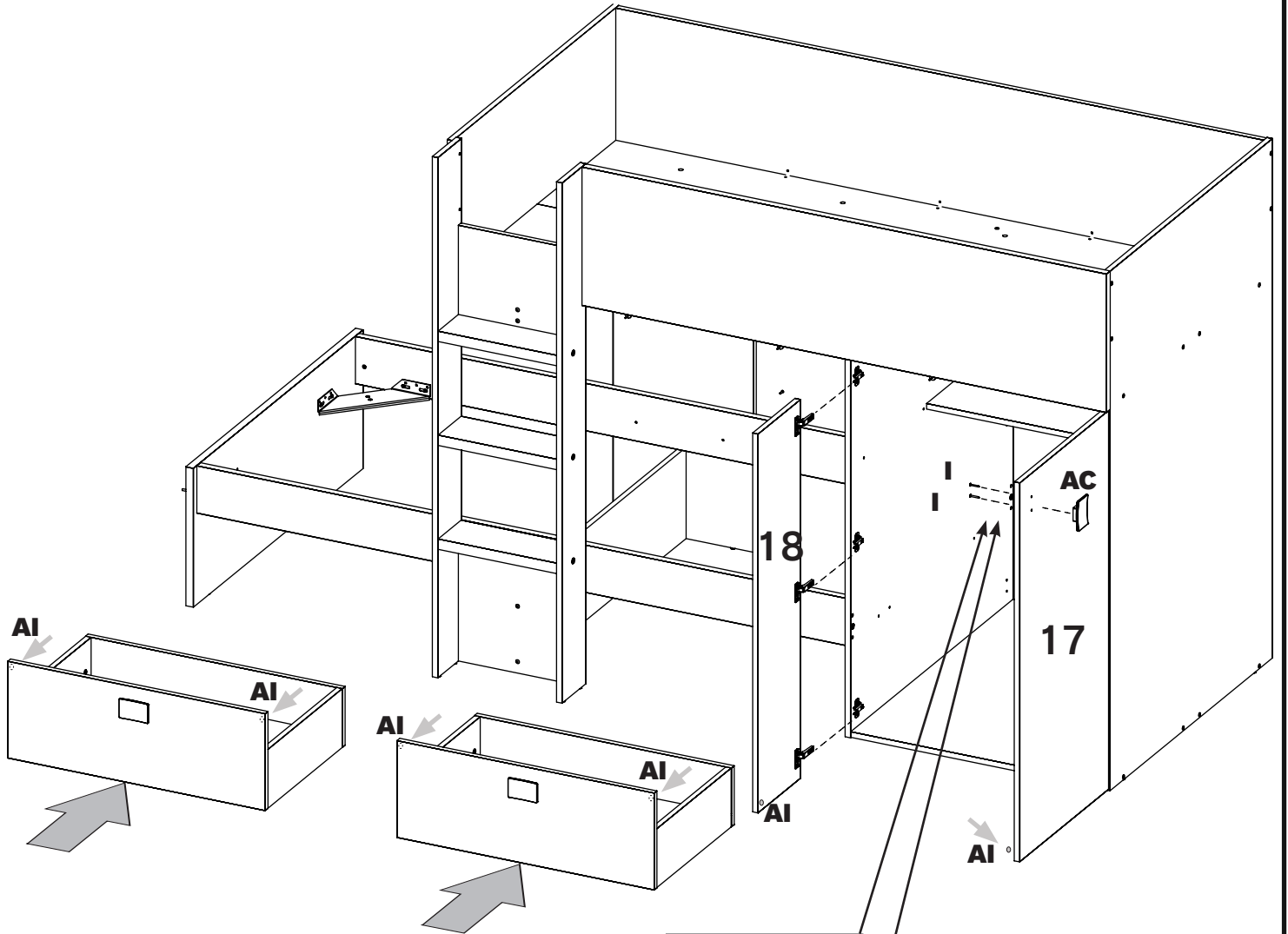

**EN** Before to tighten the screw "aa", you have to slacken a little the screw "bb"  
**ES** Antes de apretar el tornillo "aa", hay que aflojar un poco el tornillo "bb"  
**FR** Avant de presser le vis "aa", il y a que relâcher un peu le vis "bb"

**PT** Antes de apertar o parafuso "aa", deve desapertar um pouco o parafuso "bb"  
**IT** Prima di serrare la vite "aa", Allentare leggermente la vite "bb"  
**DE** Bevor die Schraube "aa" festgezogen wird lösen Sie ein wenig die schraub "bb"