

ANDAMIO DOMÉSTICO (9474-851)

ANDAMIO COMBI DE ALUMINIO • ANDAIME COMBI DE ALUMÍNIO

Exclusivamente para uso doméstico - Exclusivamente per uso domestico

Instrucciones de montaje • Instruções de montagem

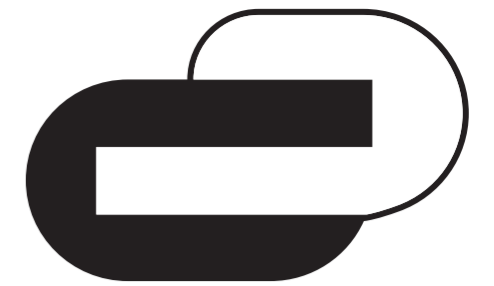

STANDERS

9474-851
(FA200EYSTS)

NF E85-200
D.Lgs 81/08

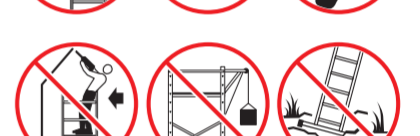
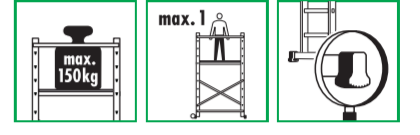
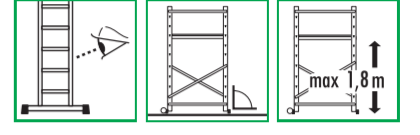
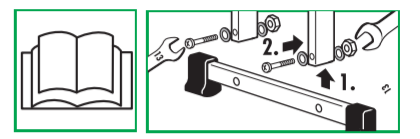

CONFORME AUX EXIGENCES DE SÉCURITÉ

EN131-4

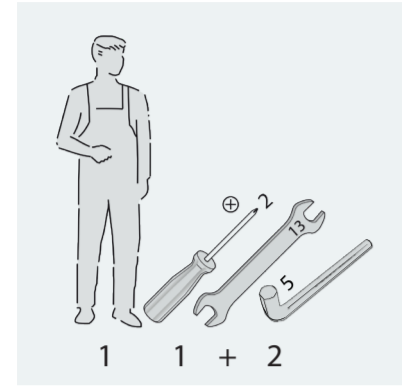
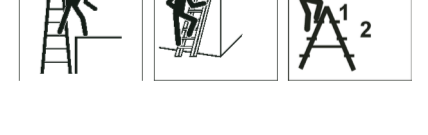
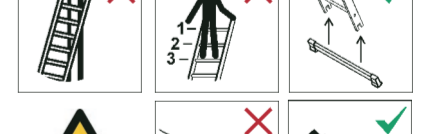
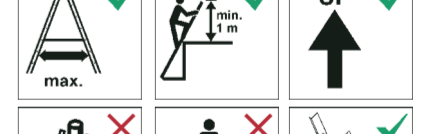

A 2

B 2

C M8 18

D L 120 cm 2

E 4

F 4

G M8 x 8,5 cm 4

H M8 40

I M8 4

J L 4 x 2 cm 4

K 2

L 1

M M8 x 4 cm 12

N M8 x 6 cm 4

O L 135 cm 2

P L 156 cm 4

Q L 134 cm 2

R 4

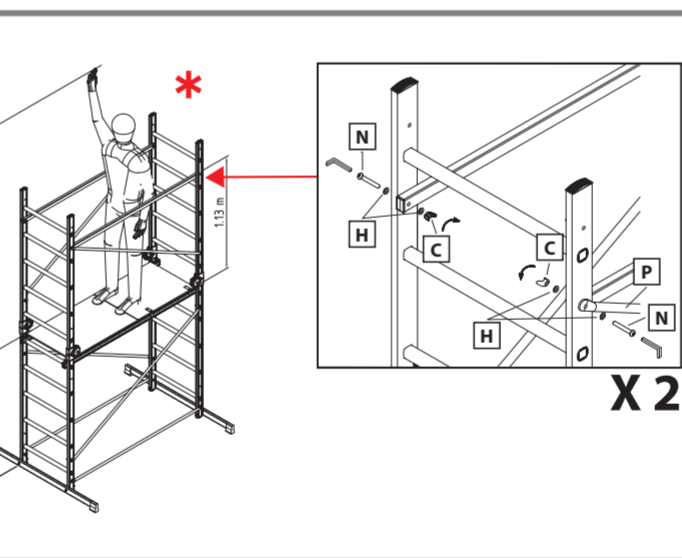
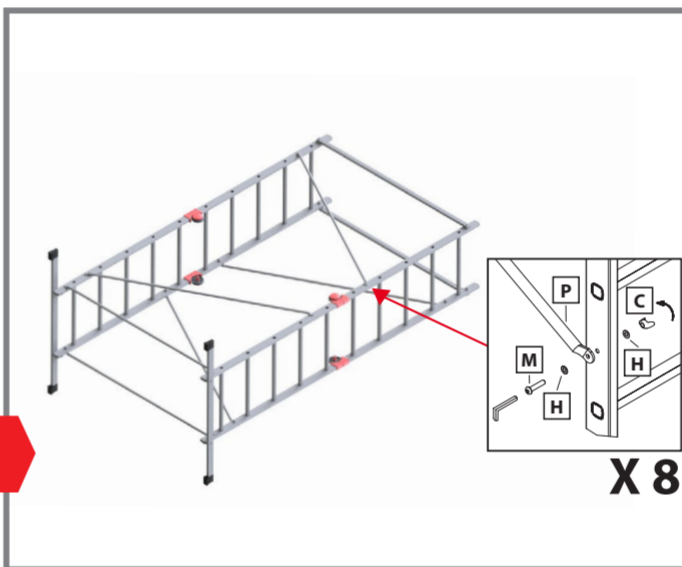
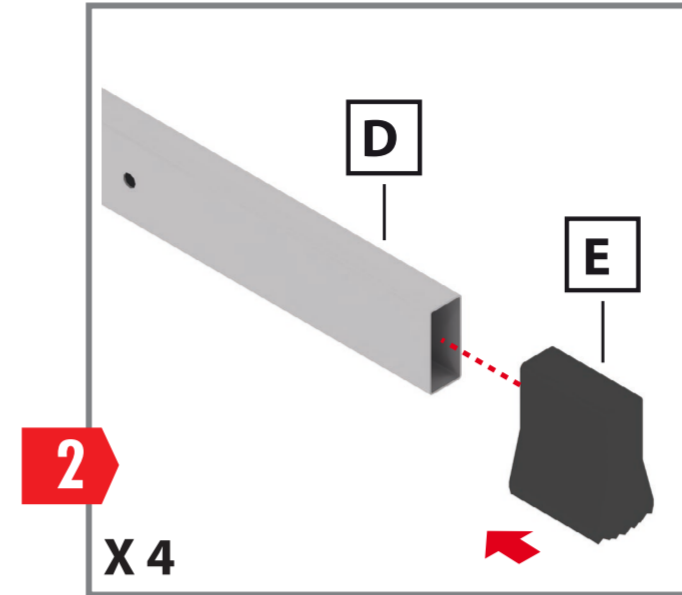
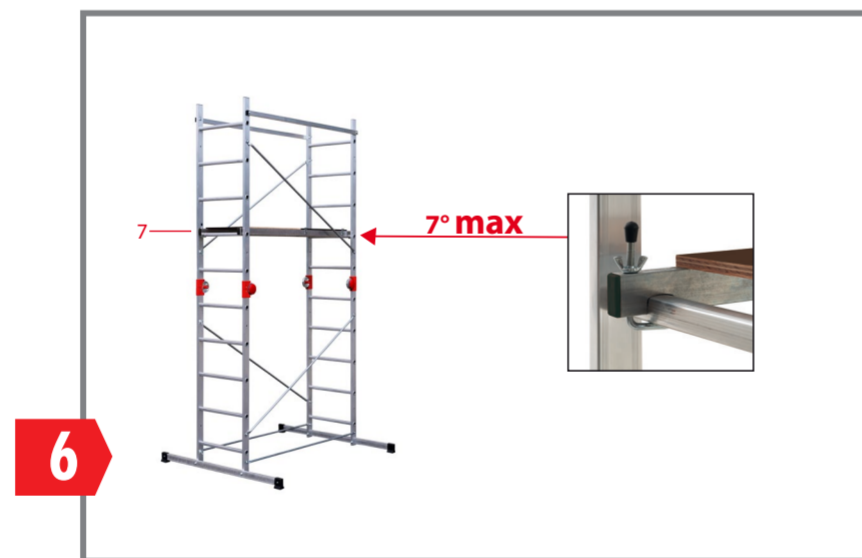
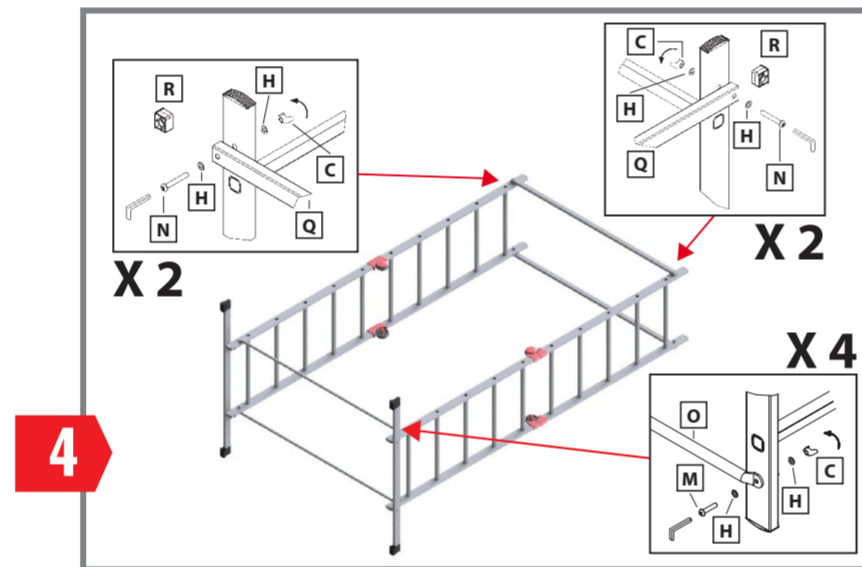
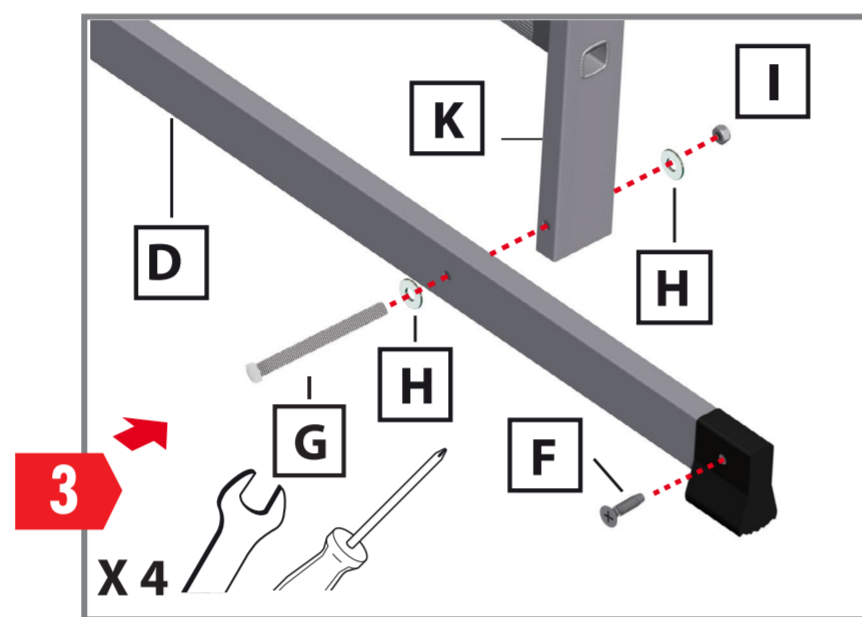
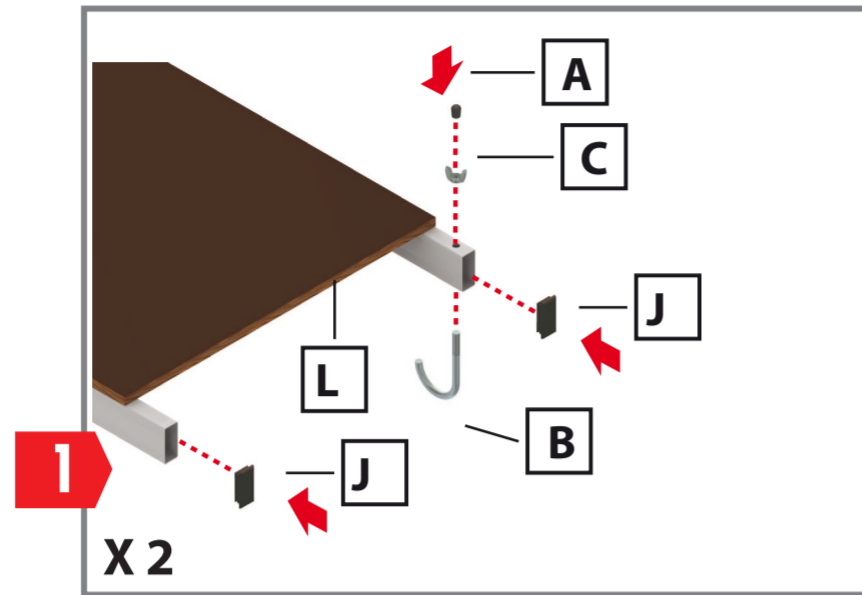

No utilizar al producto hasta que no haya sido montado completamente y se hayan leído atentamente las instrucciones de uso. Este producto no debe ser utilizado por niños y debe mantenerse lejos de su alcance. Guarde el andamio al reparo de aire, humedad, cambios climáticos. Desmonte el producto cuando no haga uso del mismo.

O produto deve ser utilizado somente depois da montagem completa e da leitura atenta das instruções de utilização. Este produto não deve ser utilizado por crianças e deve absolutamente ser mantido longe do alcance delas. Guardar o andaime protegido de ar, humidade, mudanças climáticas. Quando não for utilizado recomenda-se de desmontar o produto.

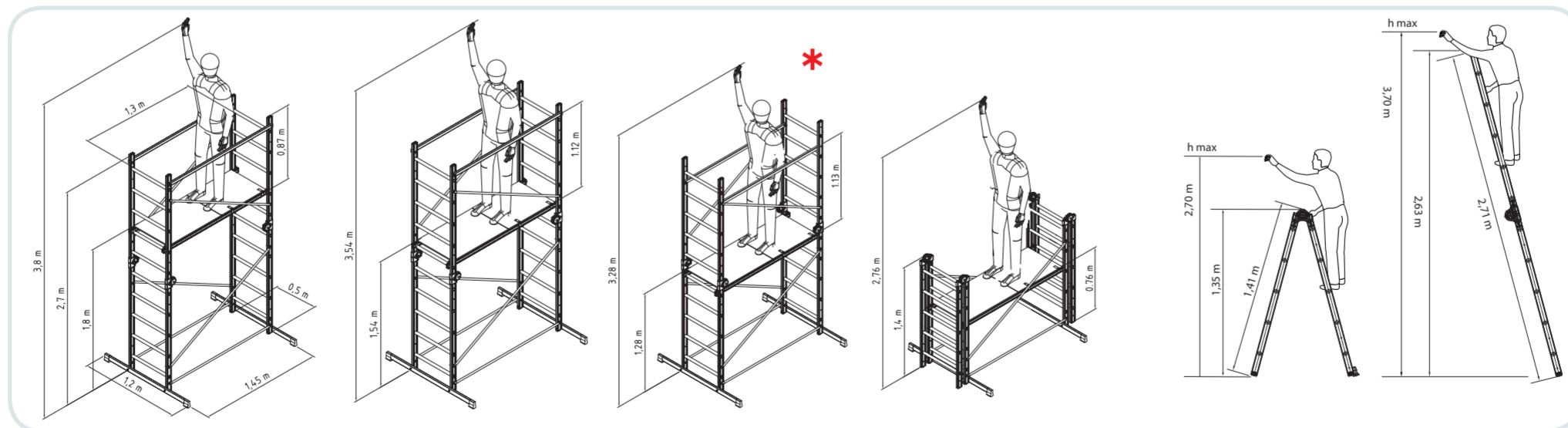

Problèmes liés au montage
Probleme im Zusammenhang mit Montage
Problems during assembling

Une ou plusieurs pièces manquantes en fin de montage
Ein oder mehr Stücke am Ende der Montage fehlen
One or more parts missing at the end of assembling

Une ou plusieurs pièces restant en fin de montage
Ein oder mehr Stücke am Ende der Montage verbleibenden
One or more pieces left at the end of assembling

Une ou plusieurs pièces défectueuses ou déformées durant le montage
Ein oder mehr defekte Teile oder bei der Montage deformiert
One or more defective parts or deformed during assembly

Problemas relacionados con el montaje
Per problemi in fase di montaggio
Problemas ligados à montagem

Una o más piezas que faltan al final del montaje
Uno o più pezzi mancanti alla fine del montaggio
Falta de uma ou mais peças no fim da montagem

Una o más piezas restantes al final del montaje
Uno o più pezzi rimanenti alla fine del montaggio
Sobra de uma ou mais peças no fim da montagem

Una o más piezas defectuosas o deformadas durante el montaje
Uno o più pezzi difettosi o deformati durante il montaggio
Uma ou mais peças defeituosas ou deformadas durante a montagem

Résolutions de problèmes
Problemlösung
How to solve the problems

Se reporter aux consignes de montage
Beziehen sich auf die Montageanleitung
Refer to the assembly instructions
Remitase a las instrucciones de montaje
Consultare le istruzioni di montaggio
Consultar as instruções de montagem

Interrompre le montage du produit
Unterbrechen die Montage des Produktes
Interrupt the product assembly

Resolución de problemas
Come risolvere i problemi
Resolução dos problemas

Interromper il montaggio del prodotto
Interrompere il montaggio del prodotto
Interromper a montagem do produto

Prendre contact avec le SAV distributeur
Kontaktieren Sie den Kundendienst
Contact the after sales service
Póngase en contacto con el servicio posventa
Contattare il servizio Post Vendita
Entrar em contacto com o serviço de pós-vendas

+ 33 (0) 5 49390202