

EAN CODE: 3276000592334
3276000597445

FR Manuel d'Instructions

ES Manual de Instrucciones

PT Manual de Instruções

IT Manuale di Istruzioni

EL Εγχειρίδιο Οδηγιών

PL Instrukcja Obsługi

RU Руководства по
Эксплуатации

KZ Пайдаланушы Нұсқаулығы

UA Інструкція з Експлуатації

RO Manual de Instrucțiuni

BR Manual de Instruções

EN Instructions Manual

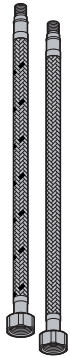
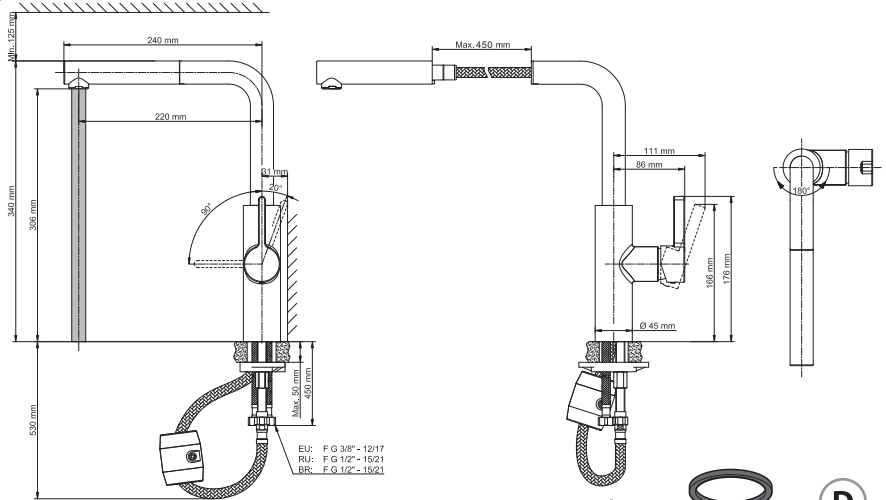

B



C

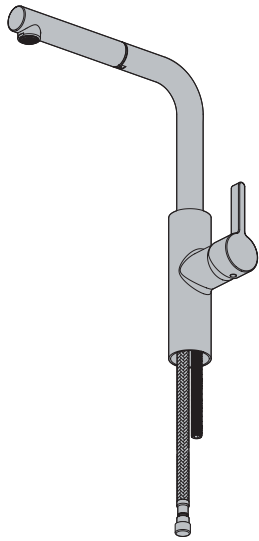

A



D

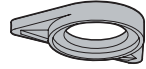

E



F



G

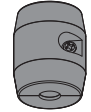

H

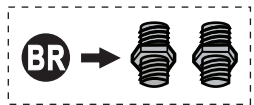

14





FR: Préparation / **ES:** Preparación / **PT:** Preparação / **IT:** Preparazione / **EL:** Προετοιμασία /
PL: Przygotowanie / **RU:** Подготовка / **KZ:** Дайындау / **UA:** Підготування / **RO:** Pregătire / **BR:** Preparação /
EN: Preparation



4



FR: Montage / **ES:** Montaje / **PT:** Montagem / **IT:** Montaggio / **EL:** Συναρμολόγηση /
PL: Montaż / **RU:** Сборка / **KZ:** Монтаждау / **UA:** Збірка / **RO:** Montaj / **BR:** Montagem /
EN: Assembly



5 → 8



FR: Utilisation eau chaude-eau froide/ **ES:** Utilización agua caliente-agua fría/ **PT:** Utilização água quente-água fria/
IT: Uso acqua calda-acqua fredda/ **EL:** Χρήση ζεστού-κρύου νερού/ **PL:** Użytkowanie zimnej wody-gorącej wody/
RU: Використання гарячої води/ **KZ:** Суық және ыстық суды қолдану/ **UA:** води - холодної води/
RO: Utilizare apă caldă-apă rece/ **BR:** Uso de água quente e fria/ **EN:** Using hot and cold water



9

FR: Changement de cartouche/ **ES:** Cambio de cartucho/ **IT:** Cambio cartuccia/ **PT:** Mudança de cartucho/
EL: Αλλαγή φυσιγγίου/ **PL:** Wymiana wkładu / **RU:** Смена картриджа/ **KZ:** Картриджді ауыстыру/
UA: Заміна картриджа/ **RO:** Schimbare cartuş/ **BR:** Substituição de cartucho/ **EN:** Replacing the cartridge



10 → 13

FR: Changement de mousseur/ **ES:** Cambio de aireador/ **PT:** Mudança de arejador/ **IT:** Cambio rompigetto/
EL: Αλλαγή αεράτορα / **PL:** Wymiana perlatora / **RU:** Смена аэратора/ **KZ:** Ауақанықтырғышты ауыстыру/
UA: Заміна аератора/ **RO:** Schimbare aerator / **BR:** Substituição do aerador/ **EN:** Replacing the aerator



14

FR: Changement de flexibles/ **ES:** Cambio de flexibles / **PT:** Mudança de flexíveis/ **IT:** Cambio flessibili/
EL: Αλλαγή λάστιχων/ **PL:** Wymiana wężyków instalacyjnych / **RU:** Смена гибкого шланга для смесителя/
UA: Заміна гнучкого шланга для змішувача/ **KZ:** Қоспалауышқа арналған иілгіш шлангты ауыстыру/
RO: Schimbare furtune flexibile/ **BR:** Substituição das mangueiras/ **EN:** Replacing the hoses



15 → 16



FR: Préparation / ES: Preparación / PT: Preparação / IT: Preparazione / EL: Προετοιμασία /
PL: Przygotowanie / RU: Подготовка / KZ: Дайындау / UA: Підготування / RO: Pregătire /
BR: Preparação / EN: Preparation

1

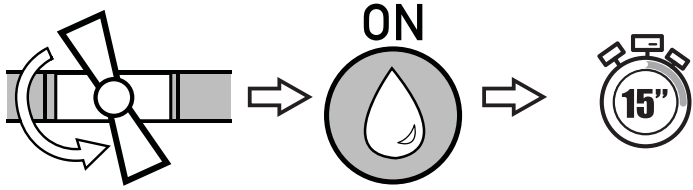

2

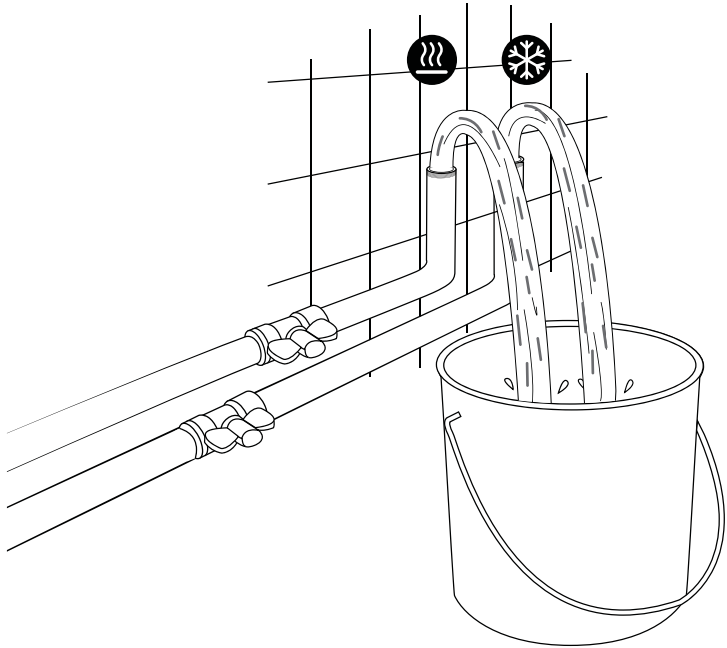

3

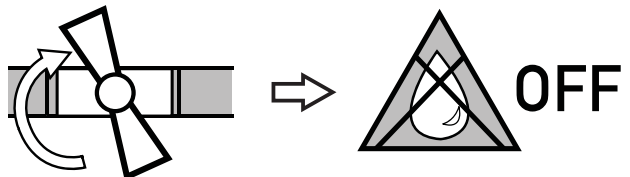

FR: Montage / ES: Montaje / PT: Montagem / IT: Montaggio / EL: Συναρμολόγηση /
PL: Montaż / RU: Сборка / KZ: Монтаждау / UA: Збірка / RO: Montaj / BR: Montagem /
EN: Assembly

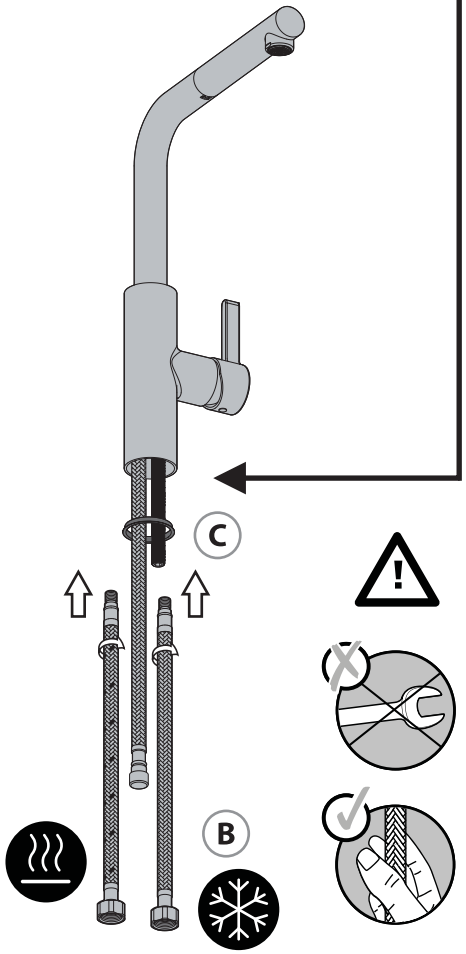
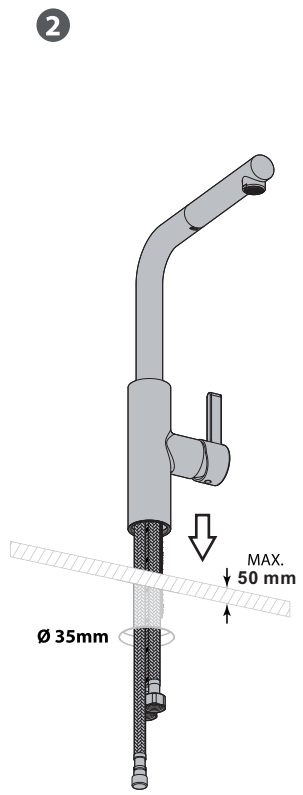
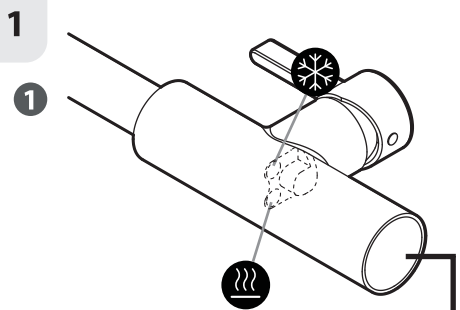
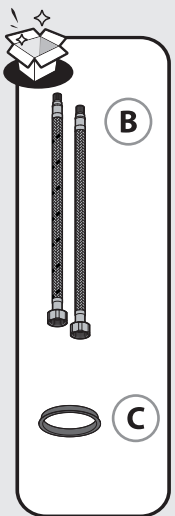

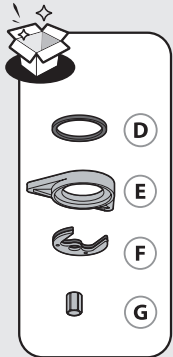

2

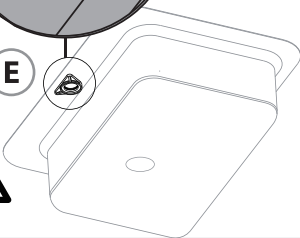
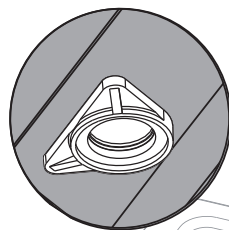
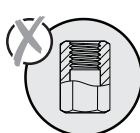
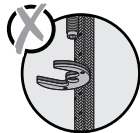
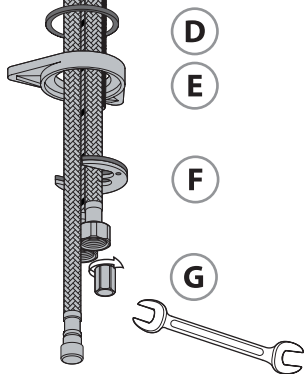
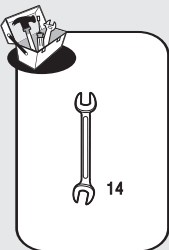
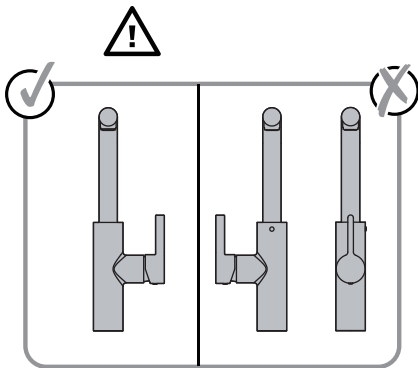
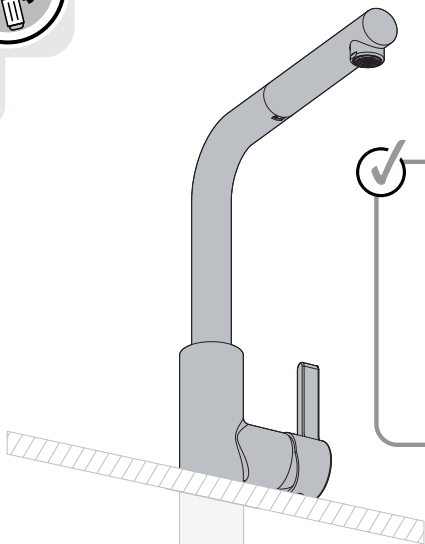

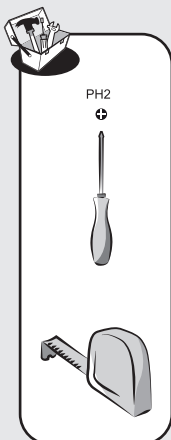
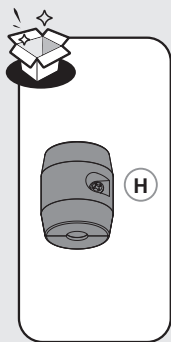

3

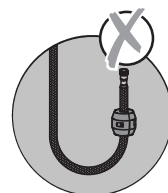
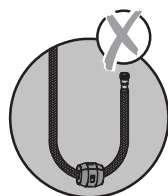
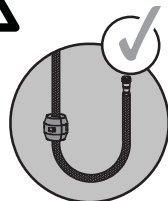
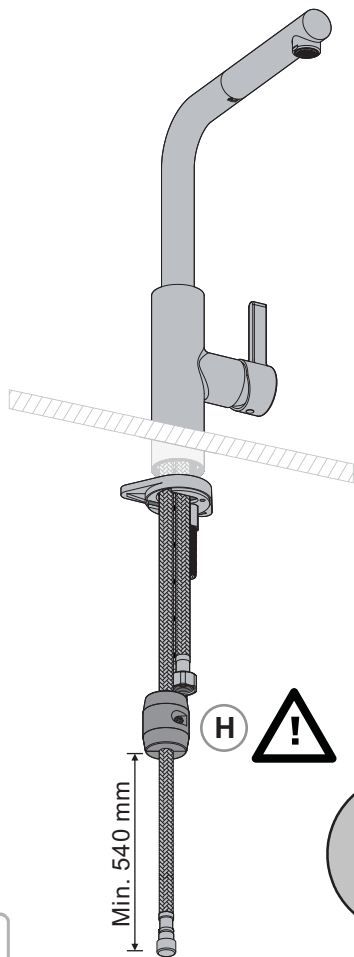
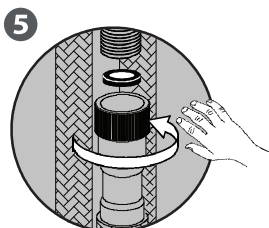
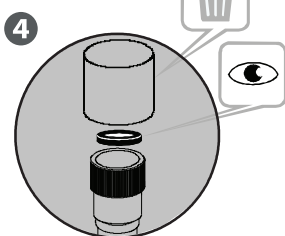
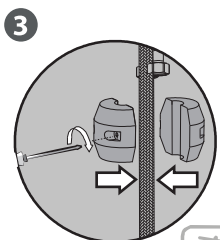
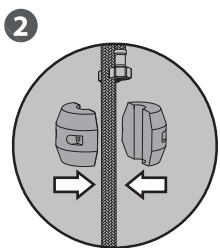
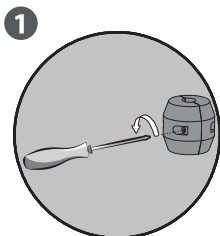

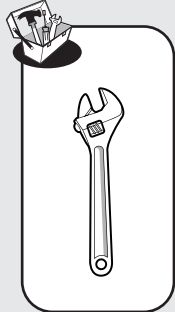

3

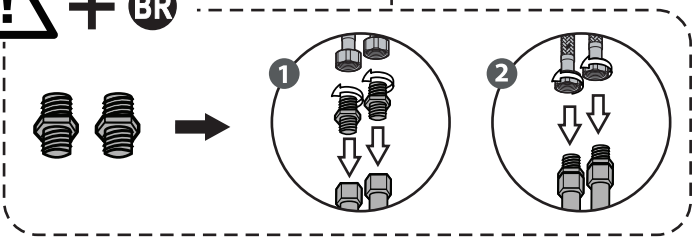
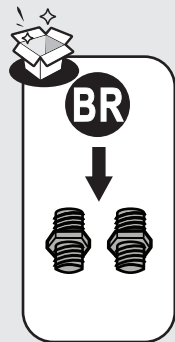
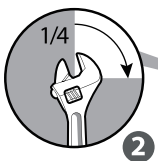
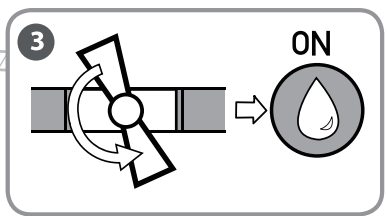
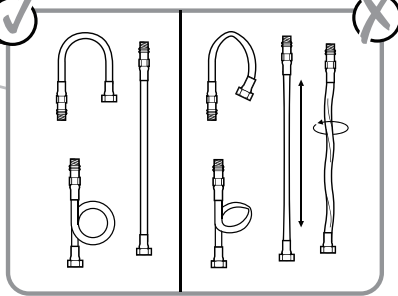
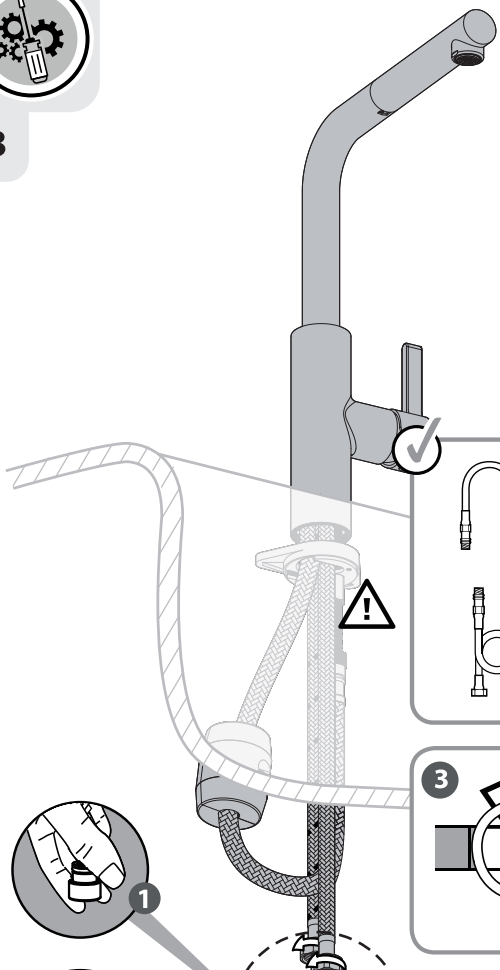



FR: Utilisation eau chaude-eau froide/ **ES:** Utilización agua caliente-agua fría/ **PT:** Utilização água quente-água fria/
IT: Uso acqua calda-acqua fredda/ **EL:** Χρήση ζεστού-κρύου νερού/ **PL:** Użytkowanie zimnej wody-gorącej wody/
RU: Використання гарячої води/ **KZ:** Суық және ыстық суды қолдану/ **UA:** води - холодної води/
RO: Utilizare apă caldă-apă rece/ **BR:** Uso de água quente e fria/ **EN:** Using hot and cold water

1

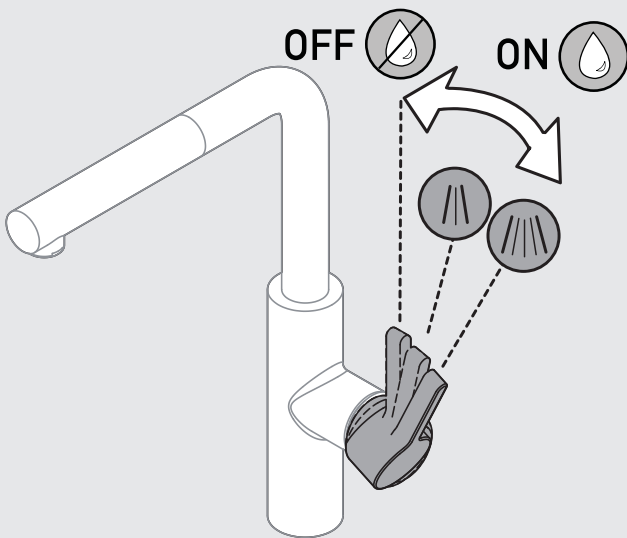
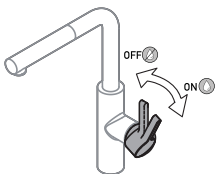

2

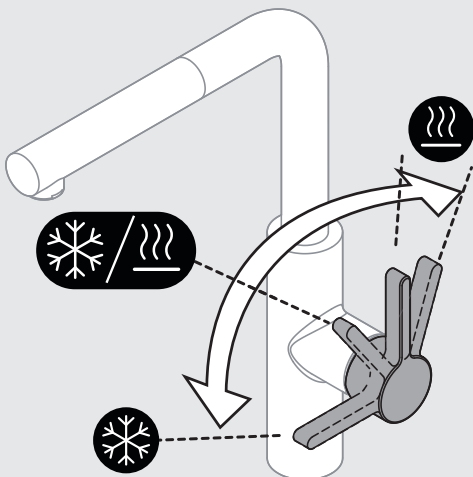



FR: Changement de cartouche/ **ES:** Cambio de cartucho/ **IT:** Cambio cartuccia/ **PT:** Mudança de cartucho/
EL: Αλλαγή φιλτράριου/ **PL:** Wymiana wkładu / **RU:** Смена картриджа/ **KZ:** Картриджді ауыстыру/
UA: Заміна картриджа/ **RO:** Schimbare cartuş/ **BR:** Substituição de cartucho/ **EN:** Replacing the cartridge

1

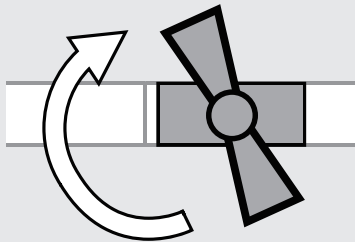

2

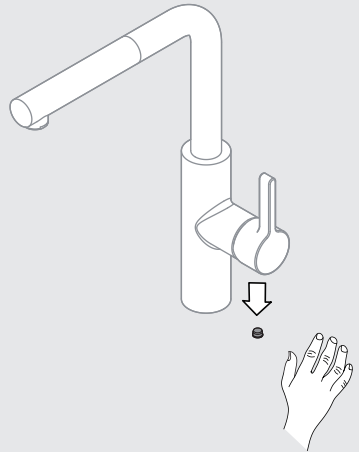

3

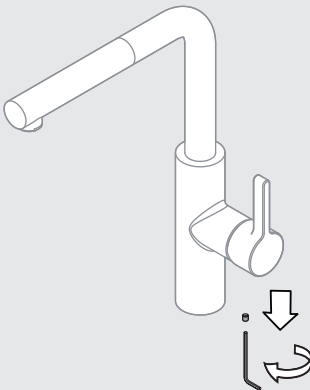

4

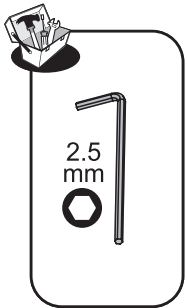
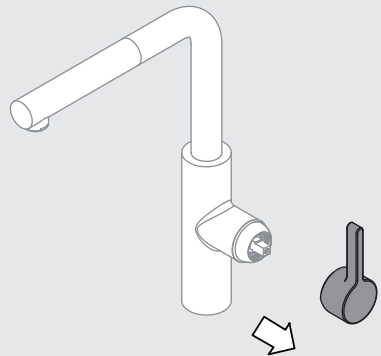

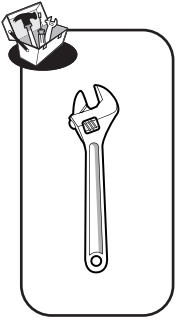

FR: Changement de cartouche/ **ES:** Cambio de cartucho/ **IT:** Cambio cartuccia/ **PT:** Mudança de cartucho/
EL: Αλλαγή φιοσιγγίου/ **PL:** Wymiana wkładu / **RU:** Смена картриджа/ **KZ:** Картриджді ауыстыру/
UA: Заміна картриджа/ **RO:** Schimbare cartuş/ **BR:** Substituição de cartucho/ **EN:** Replacing the cartridge

5



6



7



8

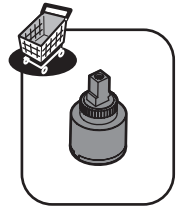
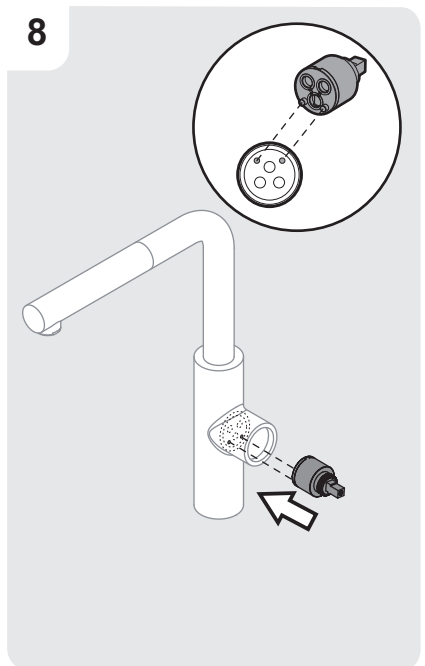

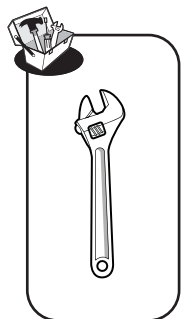

FR: Changement de cartouche/ **ES:** Cambio de cartucho/ **IT:** Cambio cartuccia/ **PT:** Mudança de cartucho/
EL: Αλλαγή φιοσίγγιου/ **PL:** Wymiana wkładu / **RU:** Смена картриджа/ **KZ:** Картриджді ауыстыру/
UA: Заміна картриджа/ **RO:** Schimbare cartuş/ **BR:** Substituição de cartucho/ **EN:** Replacing the cartridge

9

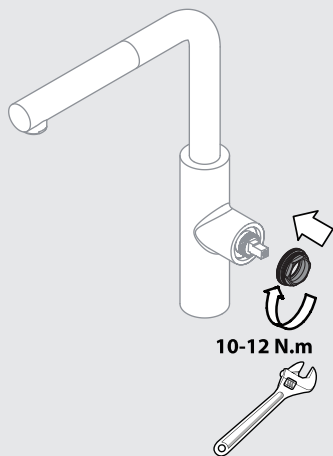

10

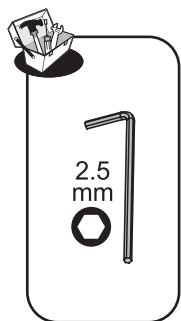
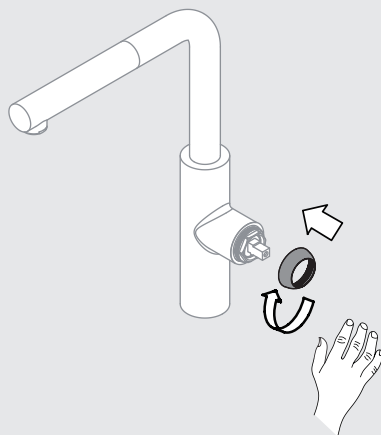

11

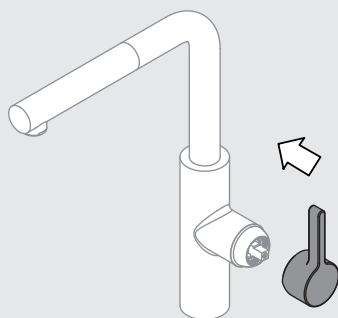

12

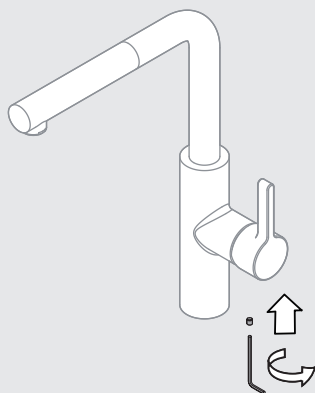



FR: Changement de cartouche/ **ES:** Cambio de cartucho/ **IT:** Cambio cartuccia/ **PT:** Mudança de cartucho/
EL: Αλλαγή φιλτράριου/ **PL:** Wymiana wkładu / **RU:** Смена картриджа/ **KZ:** Картриджді ауыстыру/
UA: Заміна картриджа/ **RO:** Schimbare cartuş/ **BR:** Substituição de cartucho/ **EN:** Replacing the cartridge

13

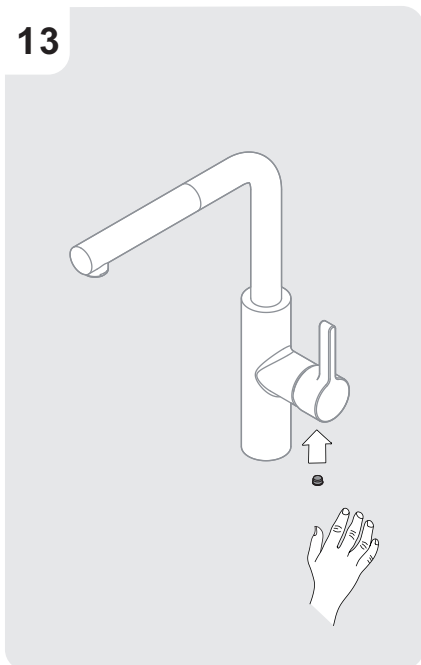

14

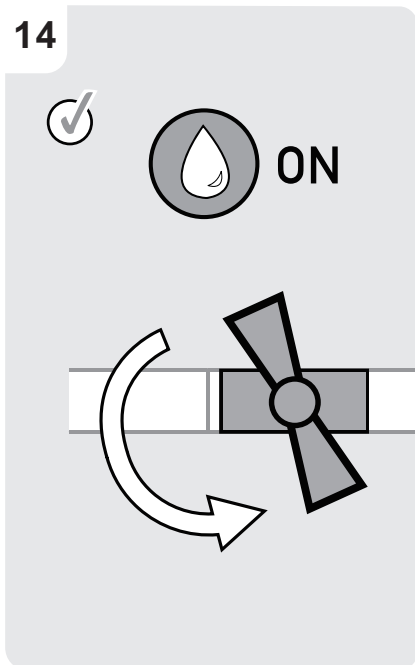

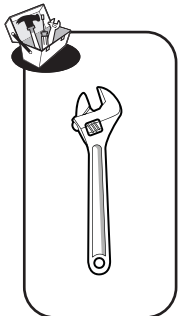

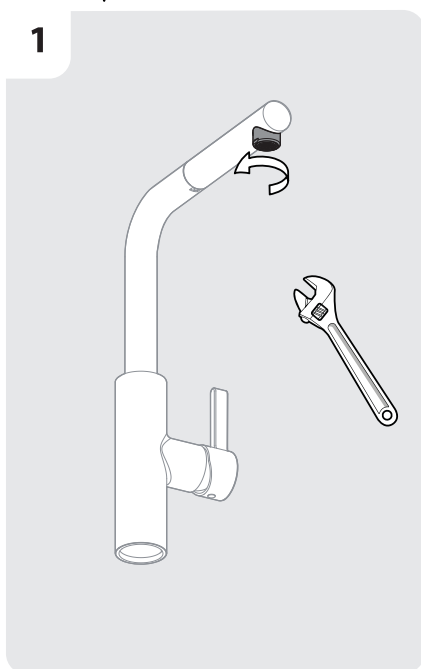

FR: Changement de mousseur/ **ES:** Cambio de aireador/ **PT:** Mudança de arejador/ **IT:** Cambio rompigitto/
EL: Αλλαγή αεράτορα / **PL:** Wymiana perlatora / **RU:** Смена аэратора/ **KZ:** Ауақанықтырғышты ауыстыру/
UA: Заміна аератора/ **RO:** Schimbare aerator/ **BR:** Substituição do aerador/ **EN:** Replacing the aerator

1

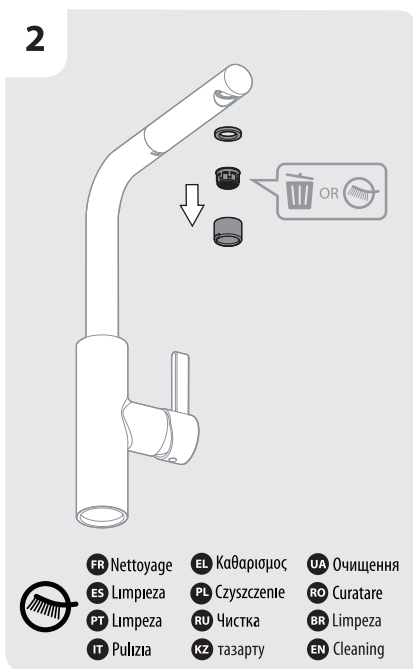

2



- | | | | |
|---|---------------------|-----------------------|--------------------|
|  | FR Nettoyage | EL Καθαρισμός | UA Очищення |
| | ES Limpieza | PL Czyszczenie | RO Curatare |
| | PT Limpeza | RU Чистка | BR Limpeza |
| | IT Pulizia | KZ тазарту | EN Cleaning |

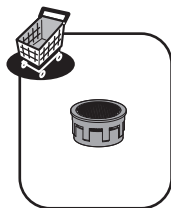

3

- | | | | |
|--------------------|-----------------|--------------------|-------------------|
| FR Vinaigre | IT Aceto | RU Уксус | RO Oțet |
| ES Vinagre | EL Ξύδι | KZ Сірке су | BR Vinagre |
| PT Vinagre | PL Ocet | UA Оцет | EN Vinegar |

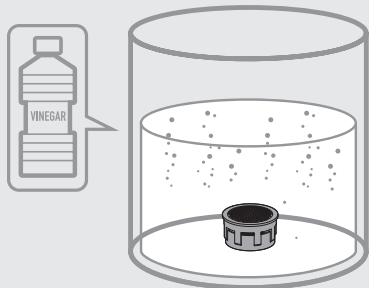

4

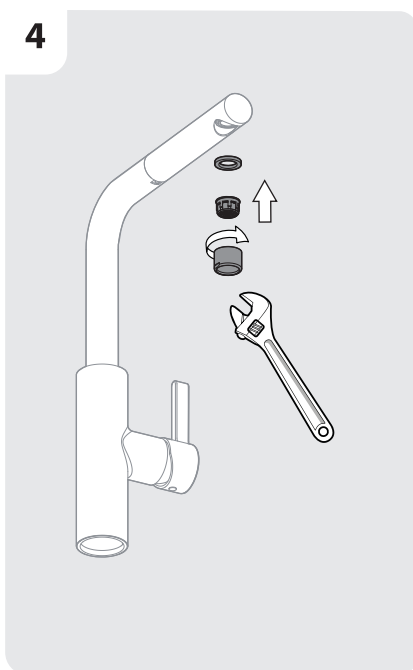

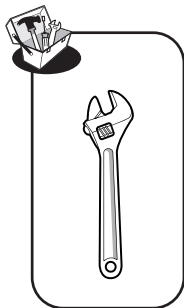

FR: Changement de flexibles/ **ES:** Cambio de flexibles/ **PT:** Mudança de flexíveis/ **IT:** Cambio flessibili/
EL: Αλλαγή λάστιχων/ **PL:** Wymiana wężyków instalacyjnych/ **RU:** Смена гибкого шланга для смесителя/
UA: Заміна гнучкого шланга для змішувача/ **KZ:** Қоспалауышқа арналған иілгіш шлангты ауыстыру/
RO: Schimbare furtune flexibile/ **BR:** Substituição das mangueiras/ **EN:** Replacing the hoses

1

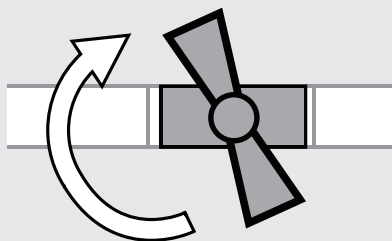

2

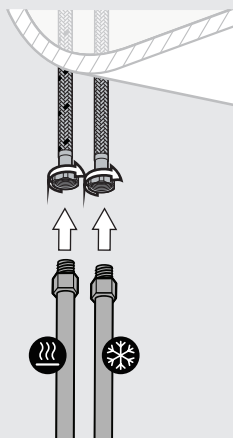

3

ON

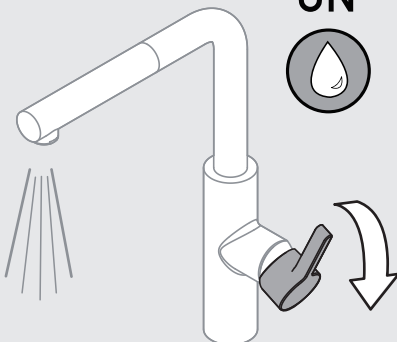

4

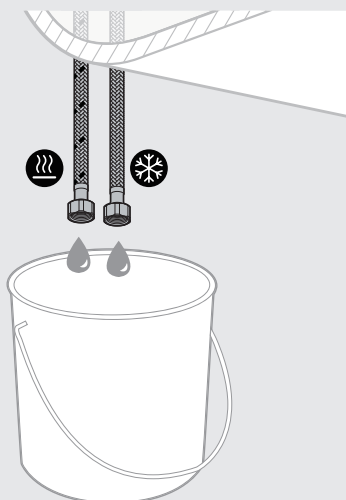



FR: Changement de flexibles/ ES: Cambio de flexibles / PT: Mudança de flexíveis/ IT: Cambio flessibili/
 EL: Αλλαγή λάστιχων/ PL: Wymiana wężyków instalacyjnych / RU: Смена гибкого шланга для смесителя/
 UA: Заміна гнучкого шланга для змішувача/ KZ: Қоспалауышқа арналған иілгіш шлангты ауыстыру/
 RO: Schimbare furtune flexibile/ BR: Substituição das mangueiras/ EN: Replacing the hoses

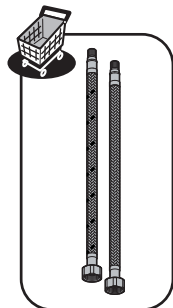
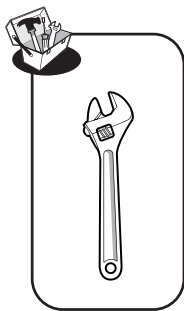

5

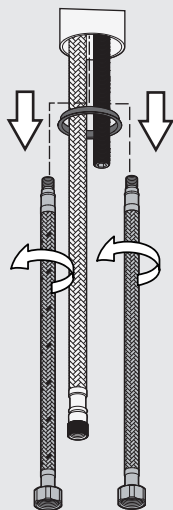

6

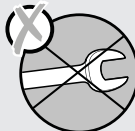
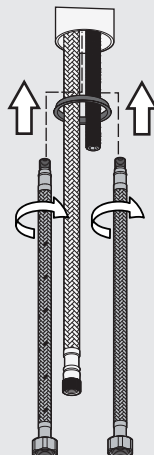
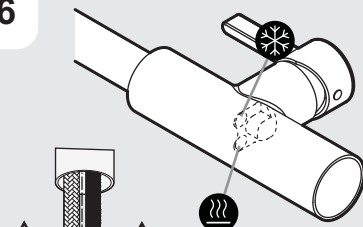

7

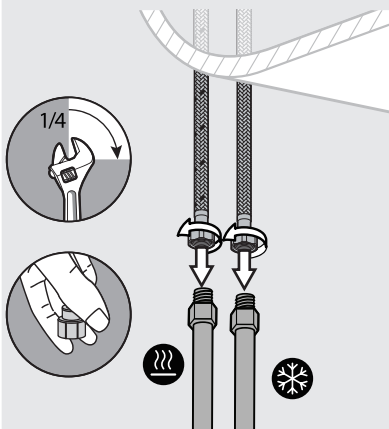

8

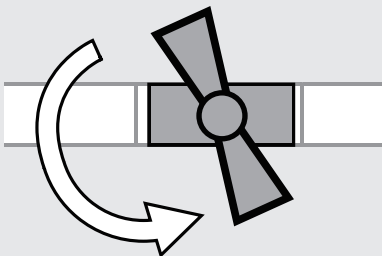



Eau claire / Agua limpia / Água limpa / Acqua pulita / Καθαρό νερό / Czysta woda / Чистая вода / Água limpa /
Чиста вода / Ara curata / таза су / Clean water



Sans solvant / Sin disolvente / Sem solventes / Senza solventi / Χωρίς διαλυτικά / Bez rozpuszczalnika / Без растворителя /
Sem solventes/ Без розчинника / Fara solvent / еріткішціз/ Solvent-free

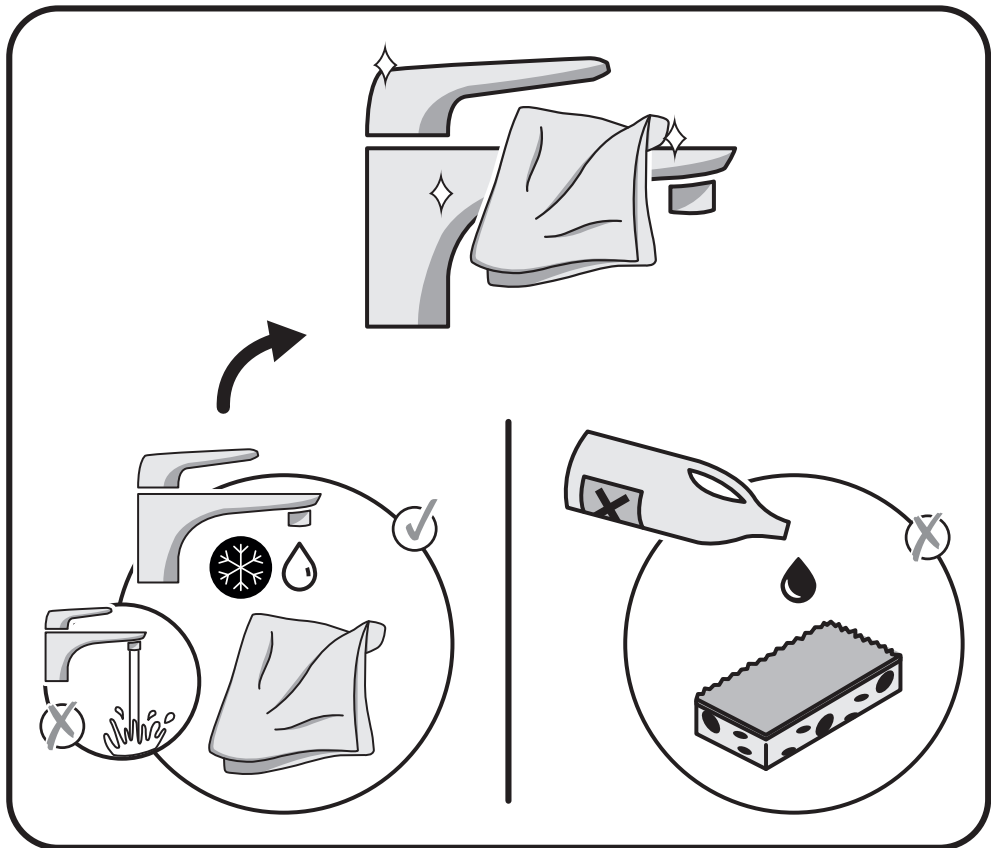

No.	Description	Code No.	QTY	Remark
1	Shower hose	553117 PULLOUT TWIST H11X1-M15X1-1500	1	
2	Weight	TQ-400G	1	
3	Fixing set	SD91311F-0-20A	1	
4	Triangle base	SD60045C-2-13	1	
5	Washer	SD61905.02-00-06	1	
6	Mixer Body	SD61905.02-00-10	1	
7	Cartridge	EN35 SD COLD DJE MIRROR	1	
8	Pressing Nut	SD97001-0-10P	1	
9	Beautifly Cover	ZS34-001	1	
10	Handle	SD2158-2	1	
11	Hand shower	SD517	1	
12	Aerator	40,0007,000	1	
13	Aerator shell	SD61905.02-00-11	1	
14	Inlet hose	TAQ-PEX-DN6-ACB H3/8-M8X1 L12 550	2	3276000592334
15	Joint	SD606-012S	2	3276000597445

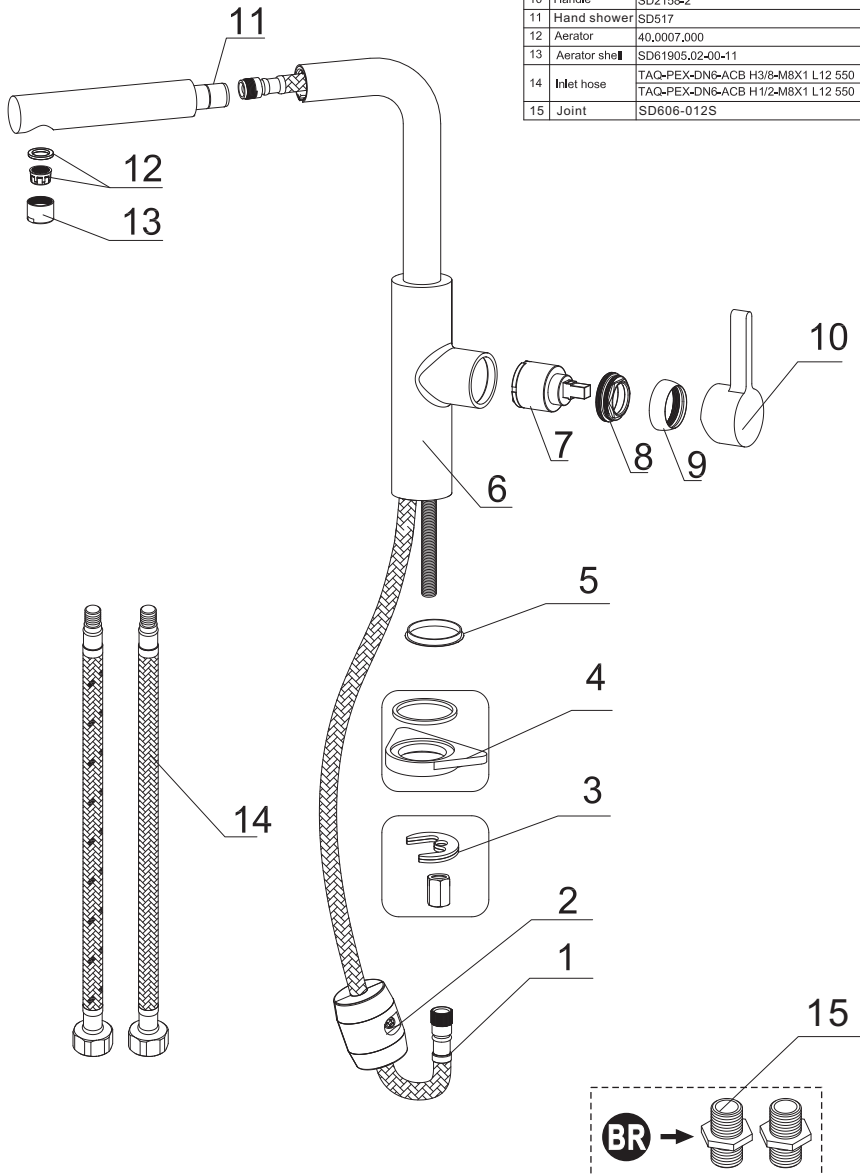

- FR** : La présence sur ce robinet d'un ou plusieurs clapet(s) anti-retour est nécessaire au bon fonctionnement de l'ensemble de votre installation en eau. Ne tentez pas de le(s) retirer.
- ES** : La presencia en este grifo de una o de varias válvula(s) de retención es necesaria para el buen funcionamiento del conjunto de su instalación de agua. No intente retirarlas.
- PT** : A presença nesta torneira de uma ou mais válvula(s) de retenção é necessária para o funcionamento adequado de toda a instalação de água. Não tente removê-la(s).
- IT** : La presenza su questo rubinetto di una o più valvole anti riflusso è necessaria per il buon funzionamento della totalità del vostro impianto in acqua. Non tentare di rimuoverle.
- PL** : Obecność jednego lub więcej zaworów zwrotnych kranu jest niezbędna dla prawidłowego funkcjonowania całej instalacji wodnej. Nie należy ich usuwać.
- EL** : Η παρουσία σε αυτήν την μπαταρία, μίας ή περισσοτέρων, βαλβίδων αντεπιστροφής είναι απαραίτητη για την καλή λειτουργία του συνόλου της υδραυλικής σας εγκατάστασης. Μην επιχειρήσετε να τις αποσπάσετε.
- RU** : Наличие на этом кране одного или нескольких обратных клапанов необходимо для для правильной работы всей водопроводной установки. Не пытайтесь его/их снимать.
- KZ** : Бұл шүмектегі бір немесе бірнеше қайырмалы қақпақашының болуы түгел су құбыры қондырғысының дұрыс жұмыс жасауы үшін қажет. Оны/оларды алып тастауға тырыспаңыз.
- UA** : Наявність на цьому крані одного або декількох зворотних клапанів необхідна для правильної роботи всієї водопровідної установки. Не намагайтеся його/їх знімати.
- RO** : Prezența pe această robinet a uneia sau mai multor supape de reținere este necesară pentru buna funcționare a întregii dvs. instalații de apă. Nu încercați să le eliminați.
- BR** : A presença de uma ou mais válvula(s) anti-retorno nessa torneira é necessária para o funcionamento adequado da sua instalação de água. Não tente remover a(s) válvula(s).
- EN** : The presence of one or more anti-return valve(s) on this tap is required for proper operation of your water setup. Please do not attempt to remove it/them.



Certificado de conformidad sanitaria.
 Atestado de conformidade sanitária.
 certificato di conformità sanitaria.
 Βεβαίωση υγειονομικής συμμόρφωσης.
 Certyfikat zgodności sanitarnej.
 Декларация о соответствии санитарным нормам
 Санитарлық талаптарға сәйкестік декларациясы
 Декларация про відповідність санітарним нормам
 Atestat de conformitate sanitară
 Certificado de conformidade sanitária.
 Declaration of sanitary conformity.
 Attestation de conformité sanitaire



* Garantie 10 ans / 10 años de garantía / Garantia de 10 años / Garanzia 10 Anni / Εγγύηση 10 ετών / Gwarancja 10-letnia / Гарантия 10 года / Кепілдік 10 жыл / Гарантія 10 років / Garantie 10 ani / 10 anos de garantia / 10-year guarantee

Made in P.R.C. 2018

ADEO Services - 135 Rue Sadi Carnot - CS 00001
 59790 RONCHIN - France

UA ТОВ «Леруа Мерлен Україна»,
 вул. Полярна 17а, м. Київ 04201, Україна

