

Rev	Design Change Note	Author	Date
A	Internal validation	RB	2018-06-12
001	First issue - proposal	RB	2018-06-15
002	Approved by client	RB	2018-06-25

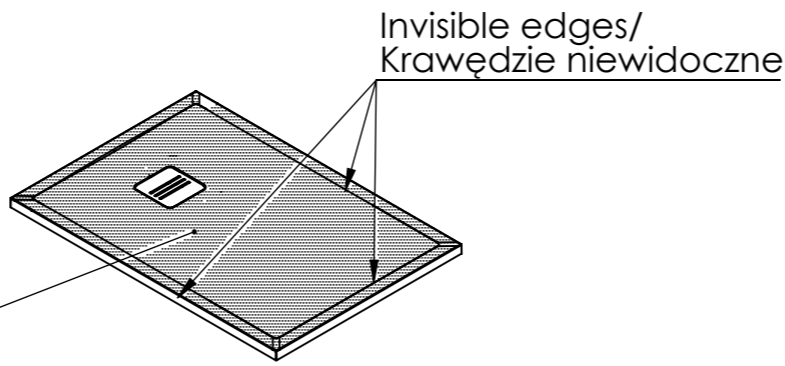

Bottom view - feet position/
Widok z dołu - rozstaw stóp

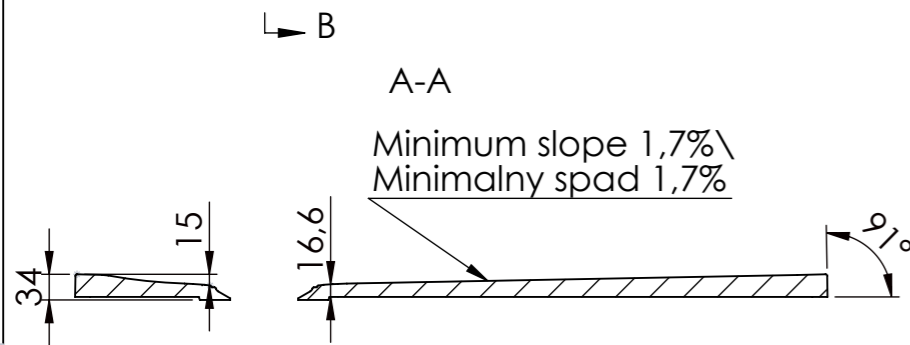
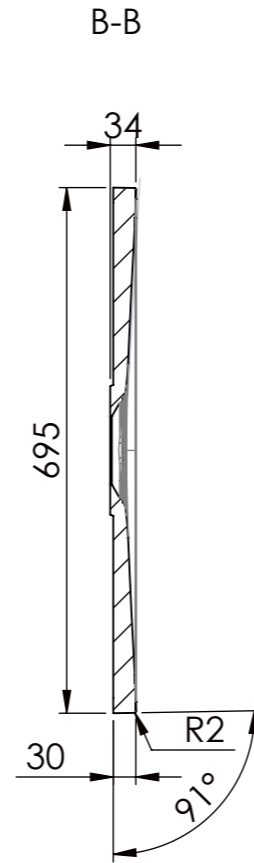
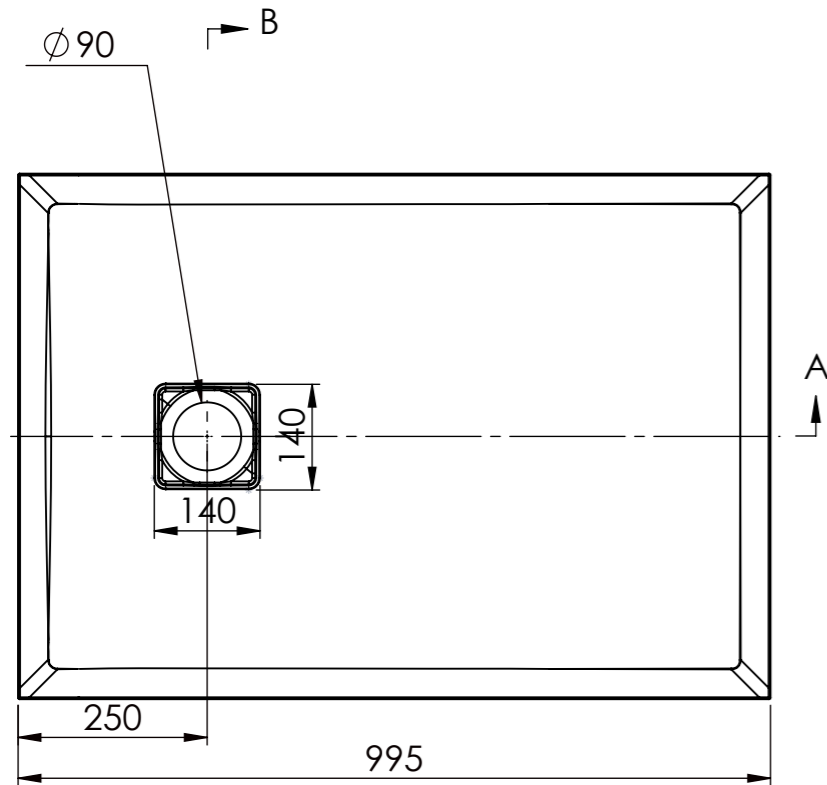
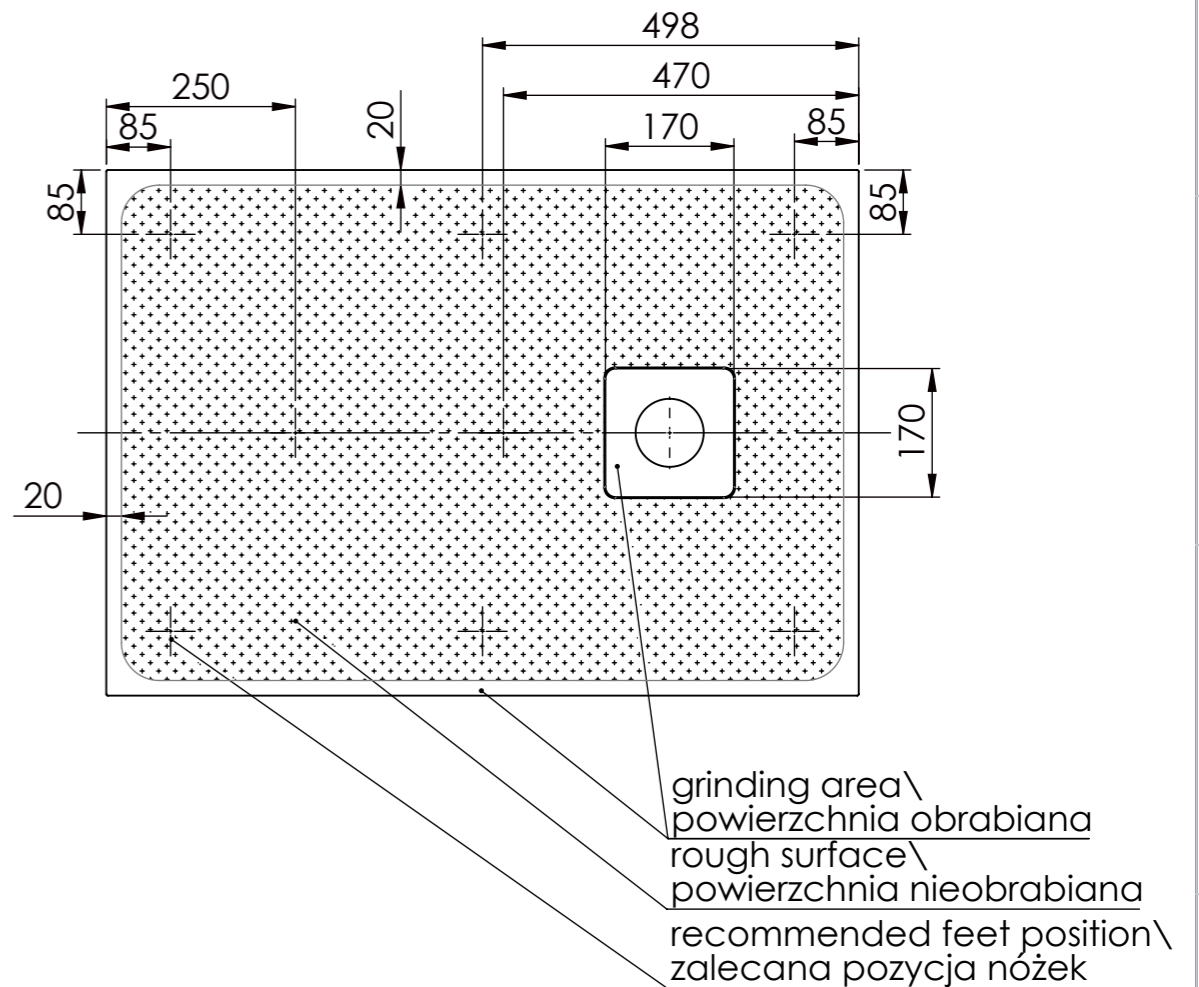

Notes/Uwagi:

1. Steel plate - see drawing 10330000055/Metalowa przykrywka - patrz rysunek 10330000055

Tolerance length/width	+5/0 mm	Drawn by	Created Date	Checked by	Art. Name: REMIX 1 1000x700
Tolerance height	+2/-2 mm	Rafal B	2018-06-12	Zbigniew P	Art. No: 6073411030xx
Tolerance plane bending	<1200 mm +2/-2 mm ≥1200 mm +3/-3 mm	Project status	Client		Mould No: FZ341103
Tolerance thickness	+2/-2 mm	Approved	LEROY MERLIN		Customer ID: 3127
Tolerance grinding	+2/0 mm			Material volume [mm³]	Overflow
Tolerance feet location	+7/-7 mm			17429633	No
Tolerance holes location	+2/-2 mm			Tap hole	0
Tolerance holes diameter	+1/-1 mm			Main dimensions L x W / H [mm]	1000 x 700 / 34
				Surface area [mm²]	1472304
				Sheet Size	A3
				Scale	1:10
				Current revision	002