

CAMPINGAZ®

Xpert 200 L • Xpert 200 L+ Xpert 200 LW • Xpert 200 LW Plus Vario Xpert 200 L Rocky • Xpert 200 L+ Rocky

**Xpert 200 L • Xpert 200 L+
Xpert 200 L Rocky • Xpert 200 L+ Rocky**

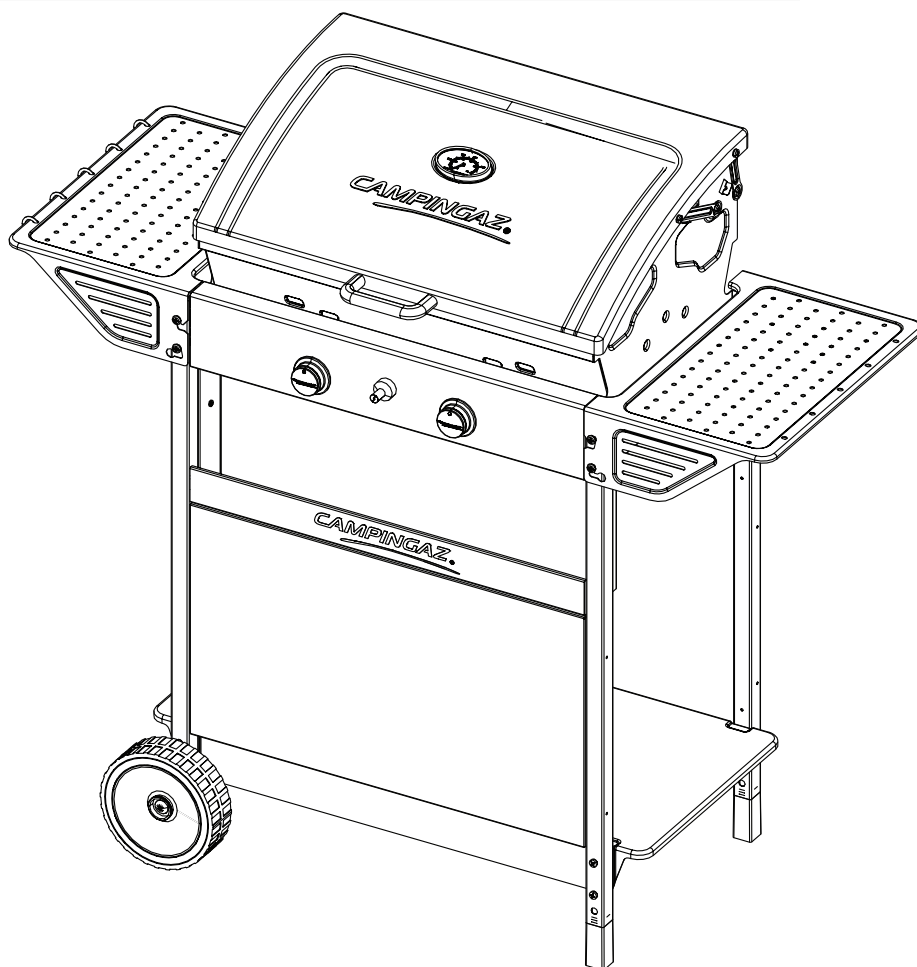
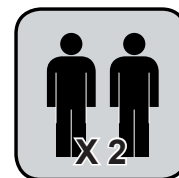

**Xpert 200 LW
Xpert 200 LW Plus Vario**

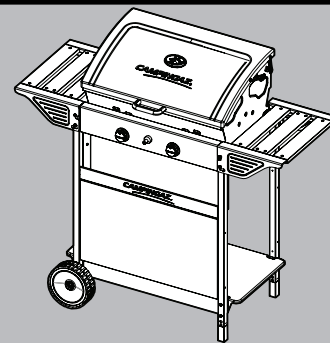

FR Instructions de montage
GB Assembly instructions
DE Montageanleitung
NL Montage-instructies
IT Istruzioni per il montaggio
ES Instrucciones de montaje
PT Instruções de montagem

NO Monteringsinstrukser
DK Monteringsvejledning
SE Monteringsanvisningar
FI Kokoamisohjeet
PL Instrukcja montażu
CZ Návod k montáži přiložen
SI Navodila za montažo

SK Návod na montáž
HU Összeszerelési-és használati utasítás
HR Upute za montiranje
RO Instrucțiuni de montaj
BG Указания за монтаж
TR Montaj
GR Οδηγίες συναρμολόγησης

- FR** * Les 8 écrous utilisés dans les étapes 13, 14 et 15 sont des écrous auto-freinés. Il faut plus de force pour les visser. Utiliser une clé de 8 ou une clé à molette. Visser jusqu'au blocage. Ensuite dévisser d'un quart de tour de façon à obtenir le bon serrage.
- GB** * The 8 nuts used in steps 13, 14 and 15 are self locking nuts. They need more force to be screwed. Use a 8mm wrench or an adjustable spanner. Screw until the stop point. Then unscrew a quarter turn in order to get the right tightness.
- DE** * Die 8 Muttern, die in den Schritten 13, 14 und 15 verwendet werden, sind selbstsichernde Muttern. Sie müssen mit grösserem Kraufaufwand verschraubt werden. Benutzen Sie einen 8mm Schlüssel oder eine verstellbaren Schraubenschlüssel. Ziehen Sie die Mutter bis zum Anschlag fest. Danach eine Vierteldrehung zurückschrauben, um den richtigen Sitz zu erreichen.
- NL** * De 8 moeren die in stap 13, 14 en 15 worden gebruikt, zijn zelfborgende moeren. Er is meer kracht nodig om ze te schroeven. Gebruik een moersleutel van 8 mm of een Engelse sleutel. Schroef tot het stoppunt wordt bereikt. Schroef vervolgens een kwartdraai terug om de juiste spanning te bereiken.
- IT** * Gli 8 dadi utilizzati nei passaggi 13, 14 e 15 sono dadi auto-bloccanti. Necessitano di una maggior forza per essere serrati. Usare una chiave da 8 mm o una chiave regolabile. Avvitare fino al completo bloccaggio. Poi, svitare di un quarto di giro per ottenere il corretto serraggio.
- ES** * Las 8 tuercas usadas en los pasos 13, 14 y 15 son tuercas de autobloqueo. Requieren más fuerza para enroscarlas. Use una llave de 8mm o una llave ajustable. Apriete hasta el tope. Luego desenrosque un cuarto de vuelta para obtener el apriete correcto.
- PT** * As 8 roscas utilizadas nas etapas 13, 14 e 15 são roscas de bloqueamento automático. Necessitam de ser apertadas com mais força. Utilize uma chave de 8mm ou uma chave ajustável. Aparafuse até ao ponto de paragem final. Em seguida soltar um quarto de volta, a fim de obter o aperto correto.
- NO** * De åtte mutrene som brukes i trinn 13, 14 og 15 er selvlåsende mutre. De krever mer kraft for å skrus inn. Bruk en 8 mm fastnøkkel eller en liten skiftenøkkel. Skru inn til stoppunktet. Skru deretter et kvart tårn tilbake for riktig stramming.
- DK** * De 8 møtrikker, der anvendes i trin 13, 14 og 15, er låsemøtrikker. Det kræver yderligere kraft at skru dem fast. Anvend en 8 mm skruenøgle eller en skiftenøgle. Skru indtil stoppunktet. Skru derefter en kvart omgang af for at opnå den korrekte tæthed.
- SE** * De 8 muttrarna i steg 13, 14 och 15 är av typen självlåsande. Mer kraft behövs för att skruva åt dem. Ta en 8 mm nyckel eller skiftnyckel. Skruva tills det säger stopp. Lossa ett kvarts varv för att få rätt spänning.
- FI** * Vaiheissa 13, 14 ja 15 käytetyt 8 mutteria ovat itsestään lukittuvia. Niitä täytyy ruuvata voimakkaammin. Käytä 8 mm kiintoavainta tai jakoavain. Ruuvaa pysäytyskohtaan saakka. Sitten ruuvaa takaisin neljänneskierron oikeaan kireyteen.
- PL** * 8 nakrętek użytych w krokach 13, 14 i 15 to nakrętki samohamowne. Ich wkręcenie wymaga większej siły. Należy użyć klucza 8 mm lub klucza nastawnego. Dokręcać do momentu końcowego. Następnie odkręcić o ćwierć obrotu, by uzyskać odpowiednie dokręcenie.
- CZ** * 8 matek používaných v krocích 13, 14 a 15 jsou samozamykací matky. Potřebují ke šroubování větší sílu. Použijte 8mm kleště či nastavitelné kleště. Šroubujte až do bodu zastavení. Pak je o čtvrt otočky uvolněte, abyste dostali správné utažení.
- SI** * 8 vijakov, ki so uporabljeni v koraku 13, 14 in 15, je samo-zapiralni vrste. Da bi jih ustrezno privili je potrebna velika moč. Uporabite 8mm francoski ključ ali prilagodljivi vičasti ključ. Privijajte dokler je mogoče. Nato odvijte za četrtno obrata, da bi dobili ustrezno tesnost.
- SK** * 8 matic použitých v krokoch 13, 14 a 15 sú poistné matice. Na ich priskrutkovanie treba viac sily. Použite 8 mm kľúč alebo nastaviteľný kľúč. Skrutkujte po značku. Na správne dotiahnutie ich odskrutkujte o štvrt' otočky.
- HU** * A 13, 14. és 15. pontban használt anyacsavarok önzáró anyák. Ezek becsavarásához nagyobb erő szükséges. Használjon 8 mm-es villáskulcsot vagy franciakulcsot. Addig csavarja be, amíg az anya megszorul. Ezután az optimális szorosság eléréséért csavarja vissza egy negyed fordulattal.
- HR** * Matice koje se koriste u koracima 13, 14 i 15 su samozaključavajuće matice. Potrebno je više snage kako bi se one pritegnule. Upotrijebite ključ od 8 mm ili podesivi ključ za matice. Pritegnite do tačke zaustavljanja. Zatim otpustite za jednu četvrtinu kruga kako biste postigli pravilnu pritegnutost.
- RO** * Cele 8 piulițe folosite la pașii 13, 14 și 15 sunt piulițe cu autoblocare. Necesită o forță mai mare pentru înșurubare. Folosiți o cheie de 8mm sau una reglabilă. Înșurubați până la capăt. Apoi desurubați un sfert de rotație pentru a obține strângerea corectă.
- BG** * Осемте гайки, използвани в стъпки 13, 14 и 15 са самозаклучващи се гайки. Необходима е по-голяма сила за затягането им. Използвайте гаечен ключ 8мм или френски ключ. Завивайте, докато спре. След това отвийте четвърт оборот, за да постигнете необходимата сила на затягане.
- TR** * 13, 14. ve 15. adımda kullanılan 8 somun, kendini kitleyen somunlardır. Bunların vidalanması için daha fazla güç gerekir. 8mm.'lik bir İngiliz anahtarı veya ayarlanabilir bir anahtar kullanın. Durma noktasına kadar çevirin. Daha sonra doğru sıklığa ulaşmak için çeyrek tur gevşetin.
- GR** * Τα 8 παξιμάδια που χρησιμοποιούνται στα στάδια 13, 14 και 15 είναι αυτοσφαιζόμενα. Χρειάζονται περισσότερη δύναμη για να βιδωθούν. Χρησιμοποιήστε κλειδί 8mm ή ρυθμιζόμενο. Βιδώστε μέχρι το σημείο στάσης. Στη συνέχεια ξεβιδώστε κατά ένα τέταρτο της βόλτας για να έχετε το σωστό σφίξιμο.



**Xpert 200 L Rocky
Xpert 200 L+ Rocky**

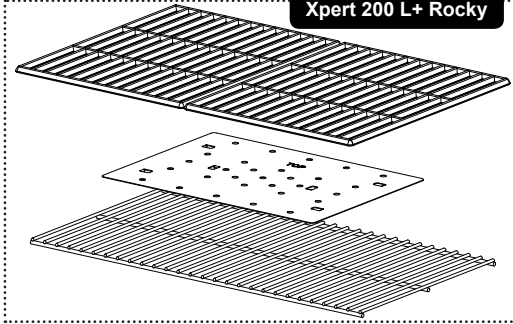

Option

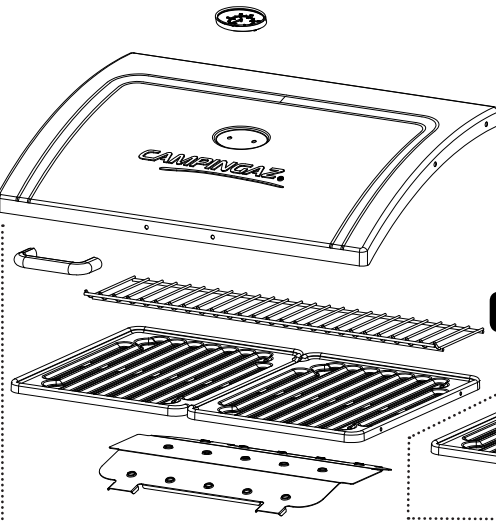

Xpert 200 LW Plus Vario

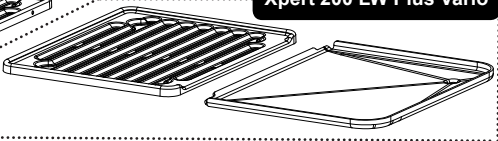

**Xpert 200 LW
Xpert 200 LW Plus Vario**

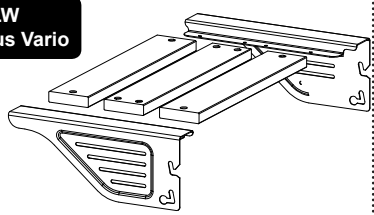



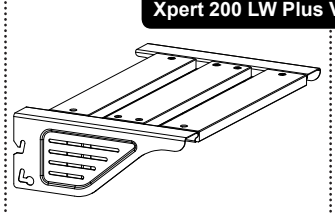

**Xpert 200 LW
Xpert 200 LW Plus Vario**

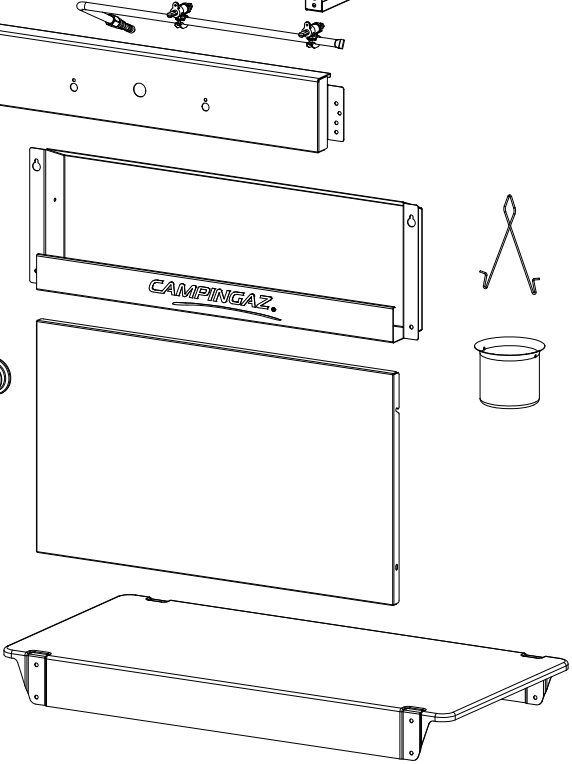
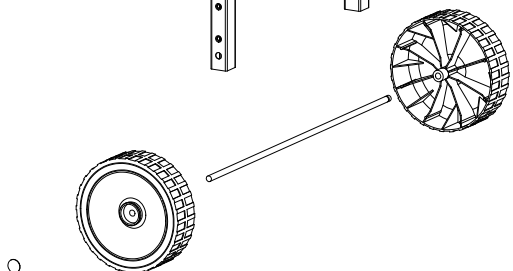
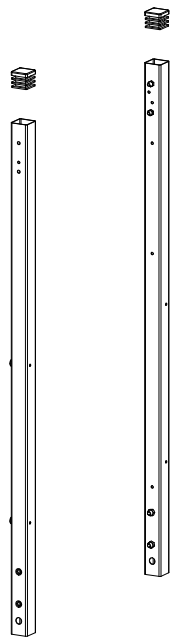
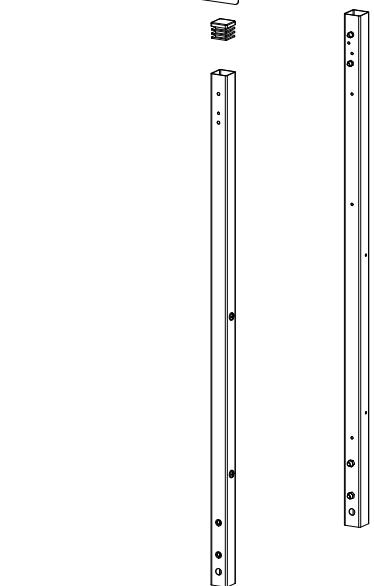
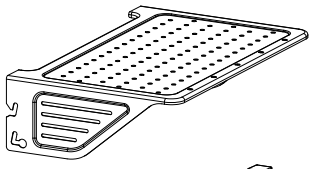
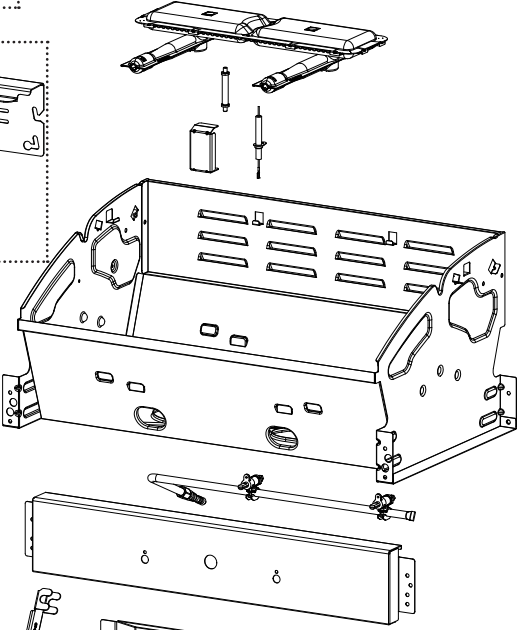
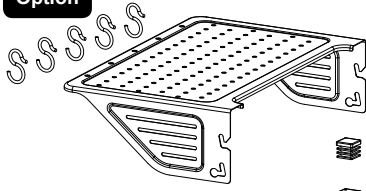

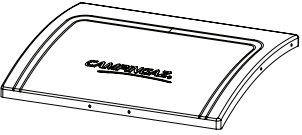
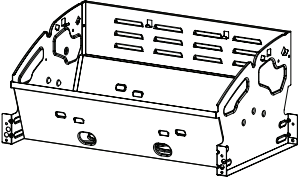
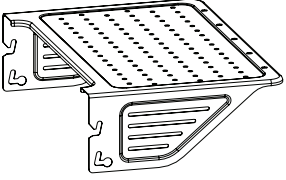
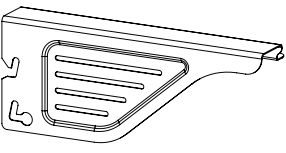
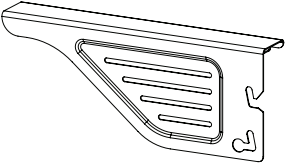
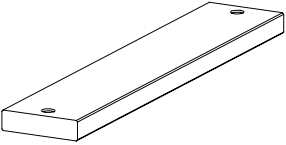
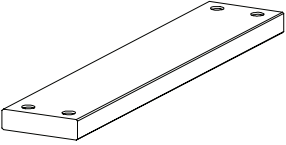
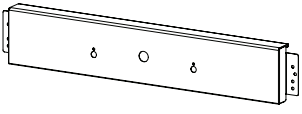
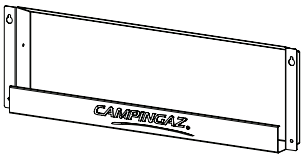
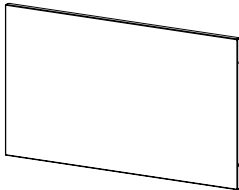

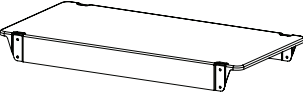
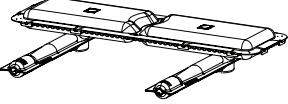
Option

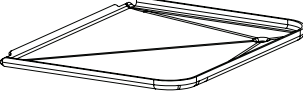
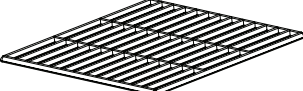
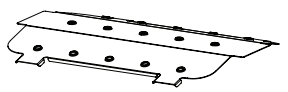
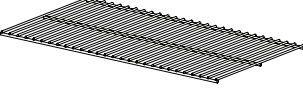
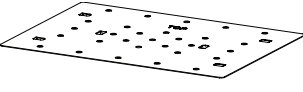



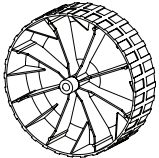
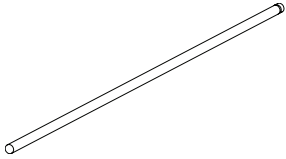
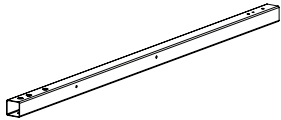



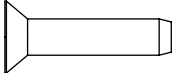

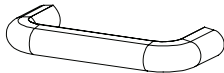
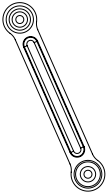

Xpert 200 L Xpert 200 L+	Xpert 200 LW Xpert 200 LW Plus Vario	Xpert 200 L Rocky Xpert 200 L+ Rocky	
1	1	1	
1	1	1	
2	0	2	
0	2	0	
0	2	0	
0	4	0	
0	2	0	
1	1	1	
1	1	1	
1	1	1	

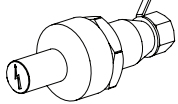

Xpert 200 L Xpert 200 L+	Xpert 200 LW Xpert 200 LW Plus Vario	Xpert 200 L Rocky Xpert 200 L+ Rocky	
1	1	1	
1	1	1	
2	2 (LW) 1 (LW Plus Vario)	0	
0	0 (LW) 1 (LW Plus Vario)	0	
0	0	2	
1	1	0	
0	0	1	
0	0	1	
Option			
1	1	1	

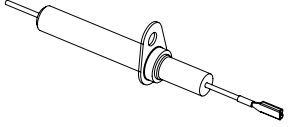
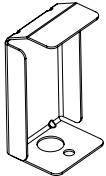

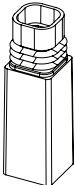
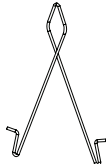
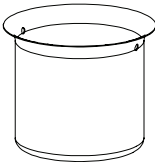

Xpert 200 L Xpert 200 L+	Xpert 200 LW Xpert 200 LW Plus Vario	Xpert 200 L Rocky Xpert 200 L+ Rocky	
2	2	2	
1	1	1	
4	4	4	

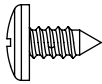
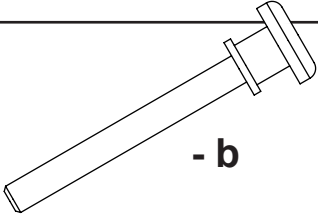
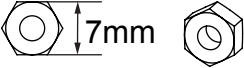
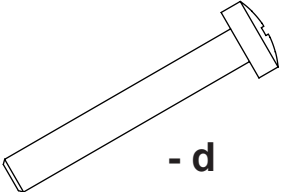
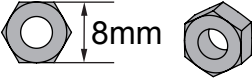
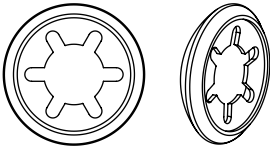
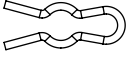
Xpert 200 L Xpert 200 L+	Xpert 200 LW Xpert 200 LW Plus Vario	Xpert 200 L Rocky Xpert 200 L+ Rocky	
0	16	0	 - p

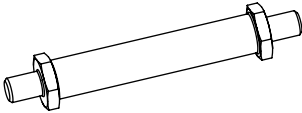
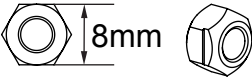
Xpert 200 L Xpert 200 L+	Xpert 200 LW Xpert 200 LW Plus Vario	Xpert 200 L Rocky Xpert 200 L+ Rocky	
1	1	1	
2	2	2	
2	2	2	
Option			

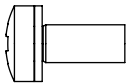
Xpert 200 L Xpert 200 L+	Xpert 200 LW Xpert 200 LW Plus Vario	Xpert 200 L Rocky Xpert 200 L+ Rocky	
2	2	2	
1	1	1	
Option			
1	1	1	
1	1	1	
4	4	4	
2	2	2	
1	1	1	
1	1	1	
1	1	1	

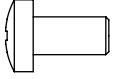
Xpert 200 L Xpert 200 L+	Xpert 200 LW Xpert 200 LW Plus Vario	Xpert 200 L Rocky Xpert 200 L+ Rocky	1:1 
13	13	13	 - a
8	8	8	 - b
9	9	9	 7mm - c
8	8	8	 - d
10	10	10	 8mm - e
1	1	1	
1	1	1	
2	2	2	 - f
1	1	1	
8	8	8	 8mm - g

Xpert 200 L Xpert 200 L+	Xpert 200 LW Xpert 200 LW Plus Vario	Xpert 200 L Rocky Xpert 200 L+ Rocky	1:1 
8	8	8	 - h
5	5	5	 - n
2	2	2	 - i
1	1	1	 - j

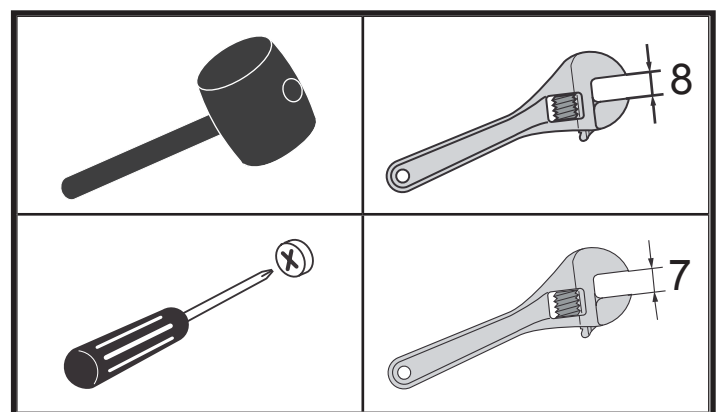

01



X 4

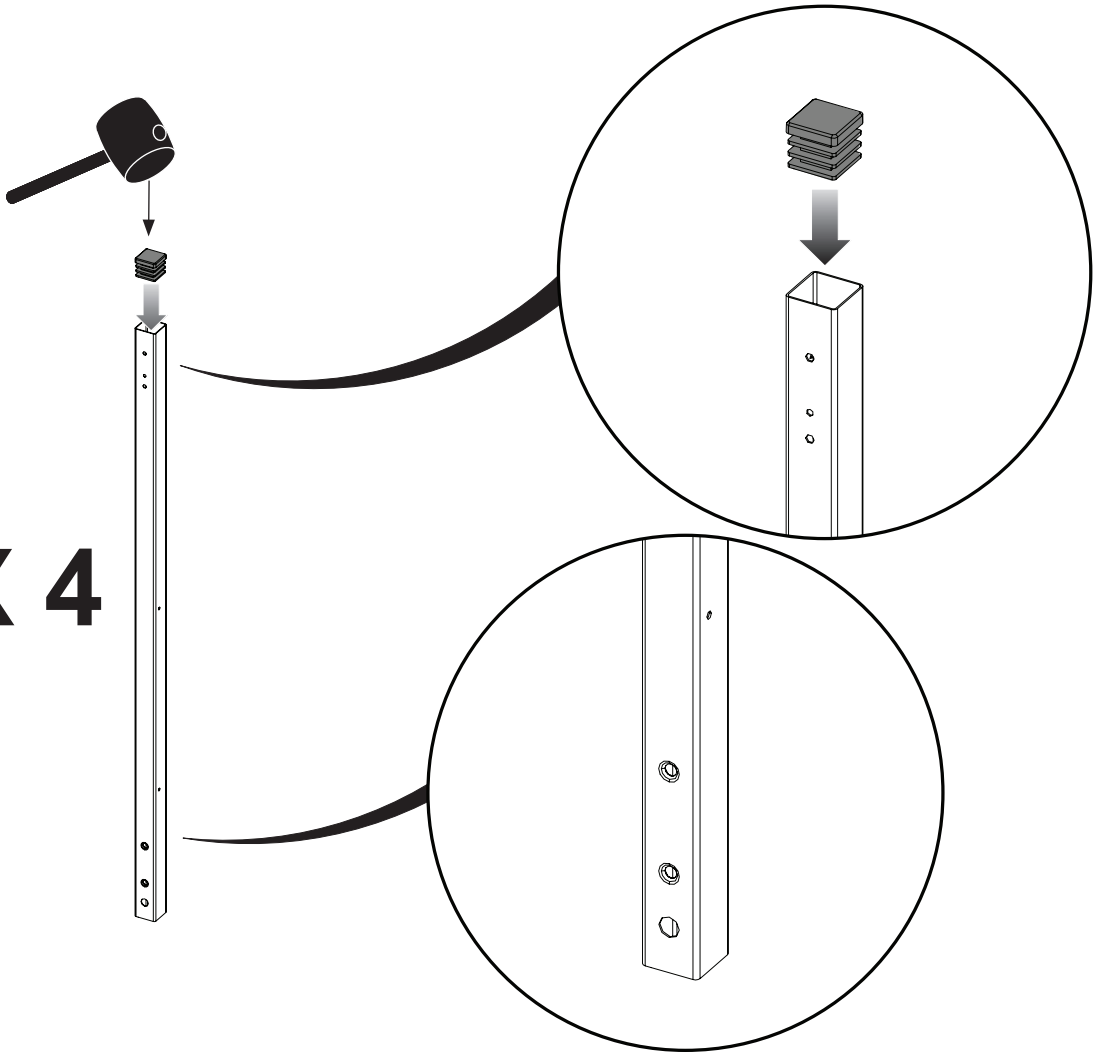

02

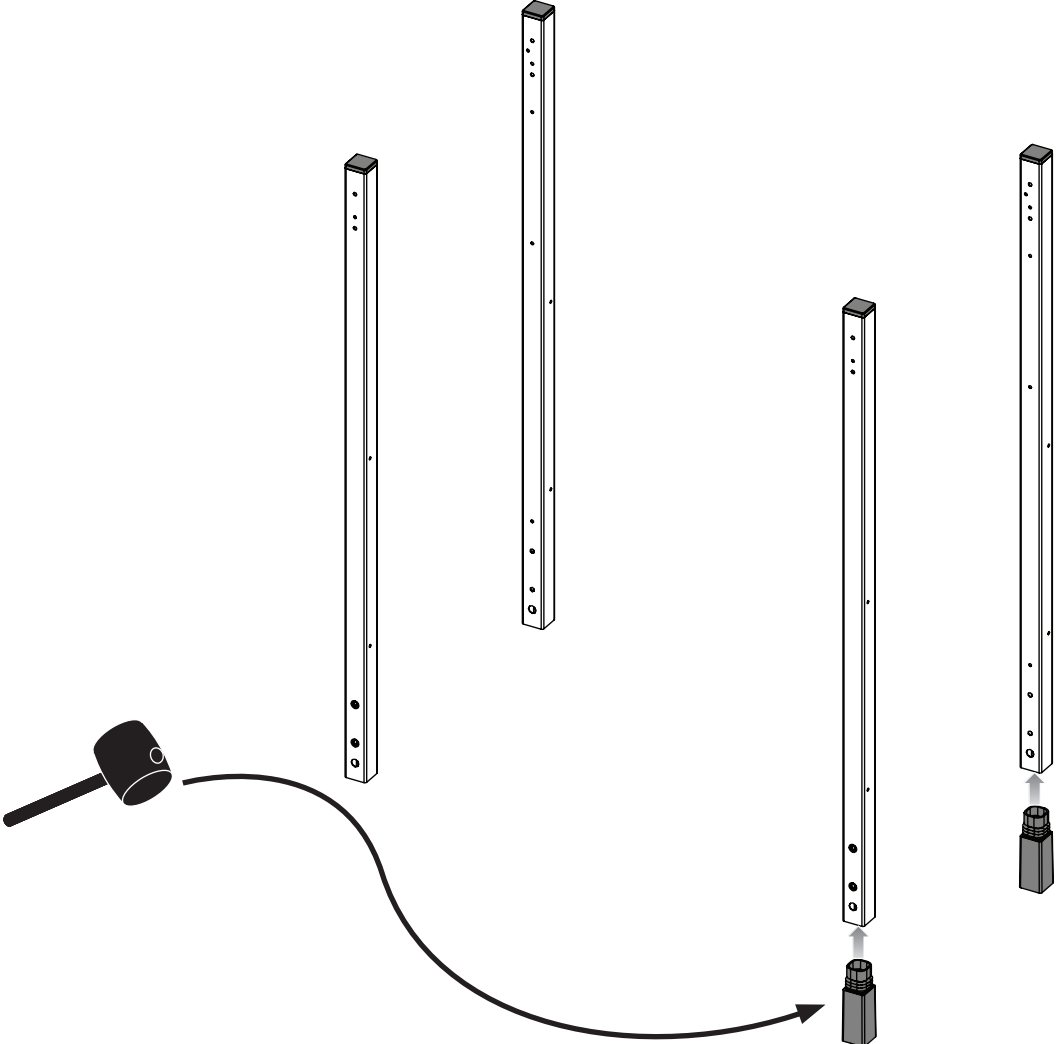
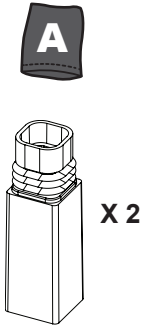

03

- C**
- a**
- X 4

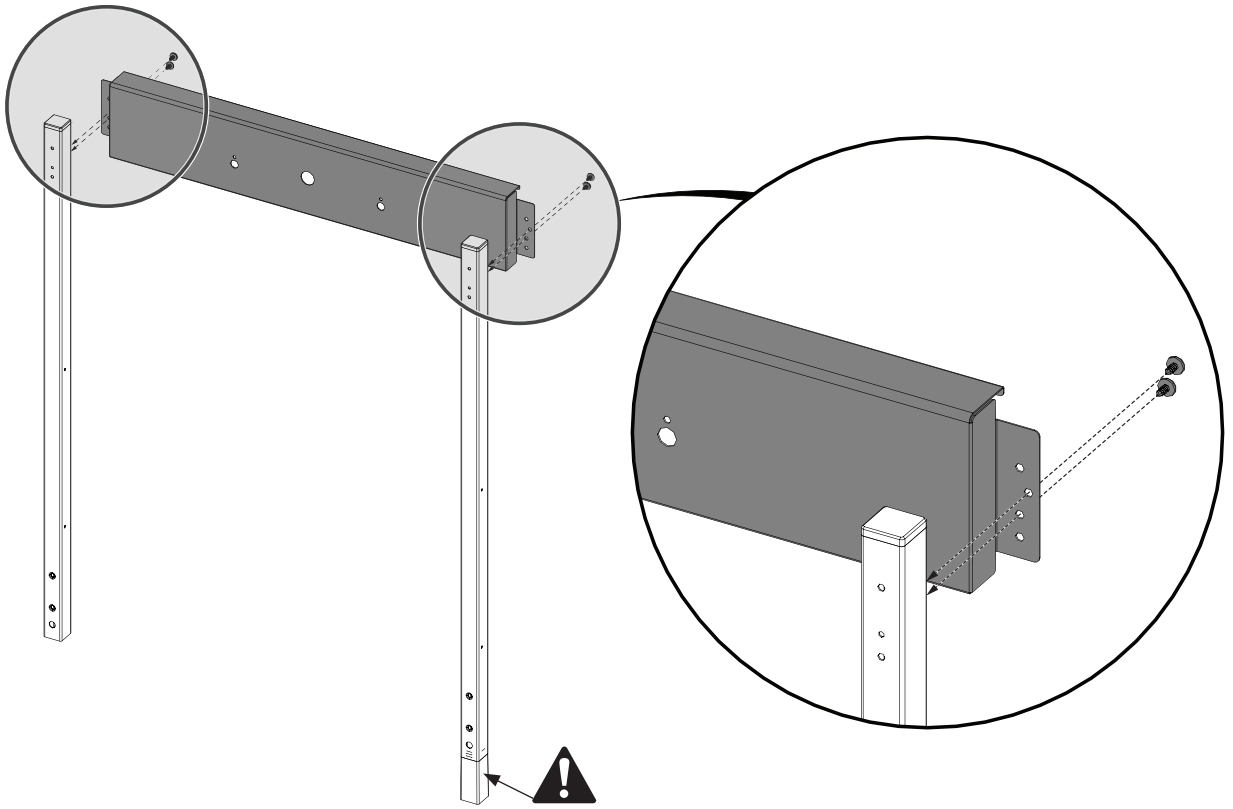

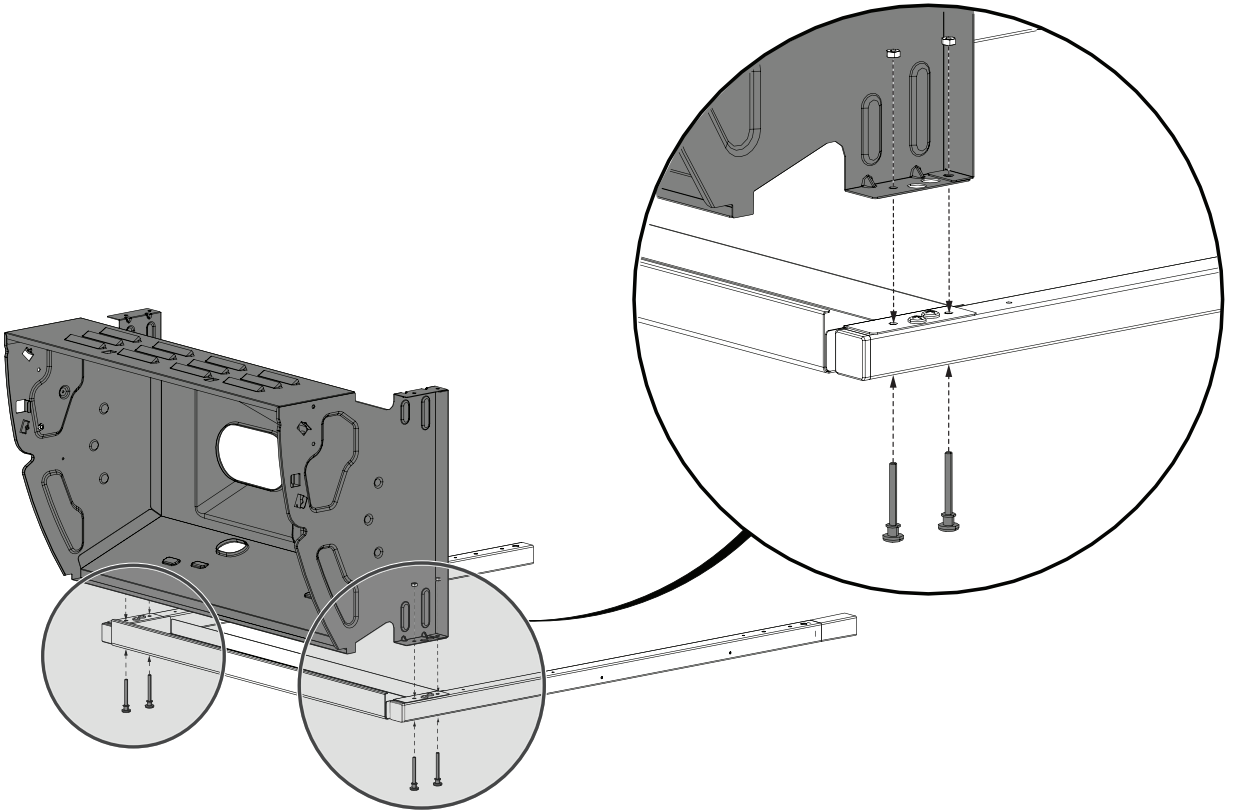

04

- C**
- b**
- X 4
- c**
- X 4
- 7



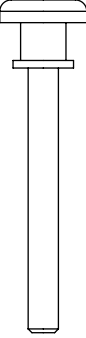

05

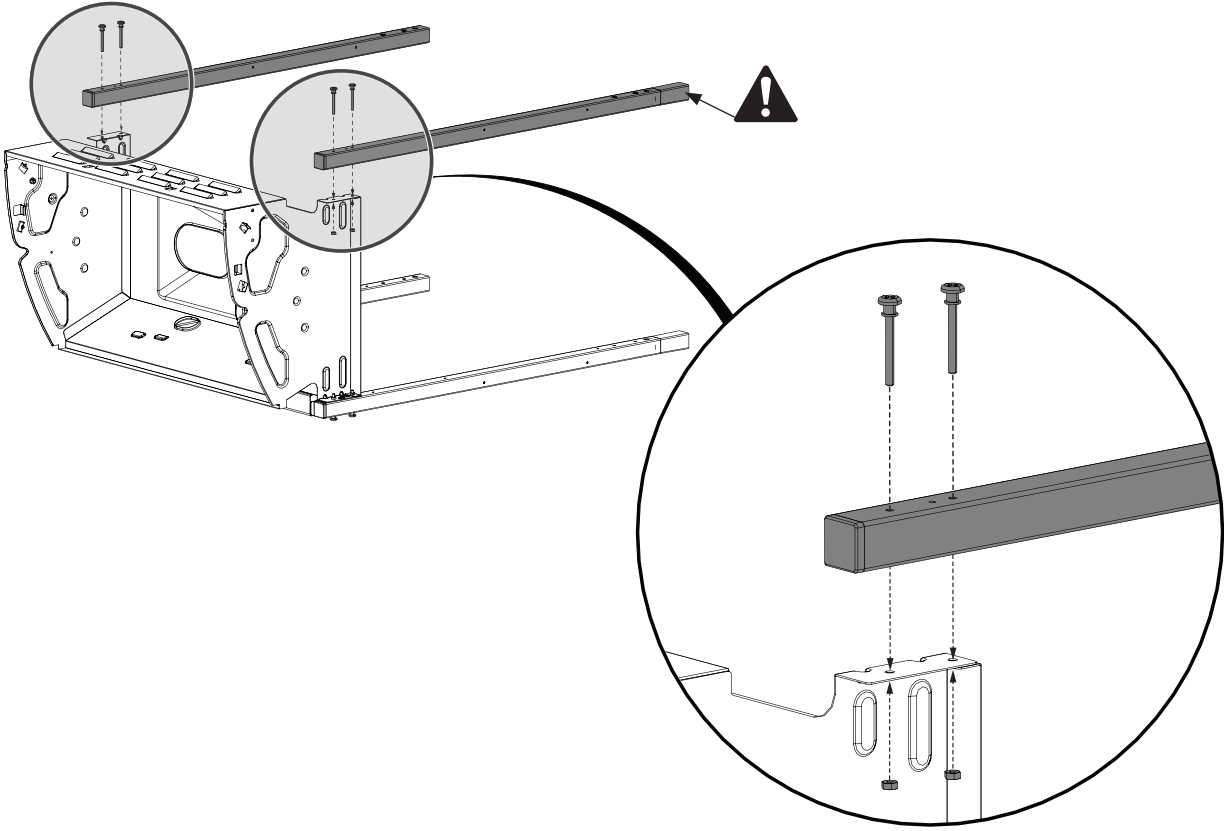
- c**
-  X 4
- b**
-  X 4
- c**
- 

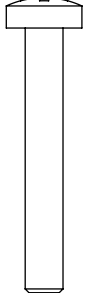

06

- c**
-  X 8
- d**
-  X 8
- e**
- 

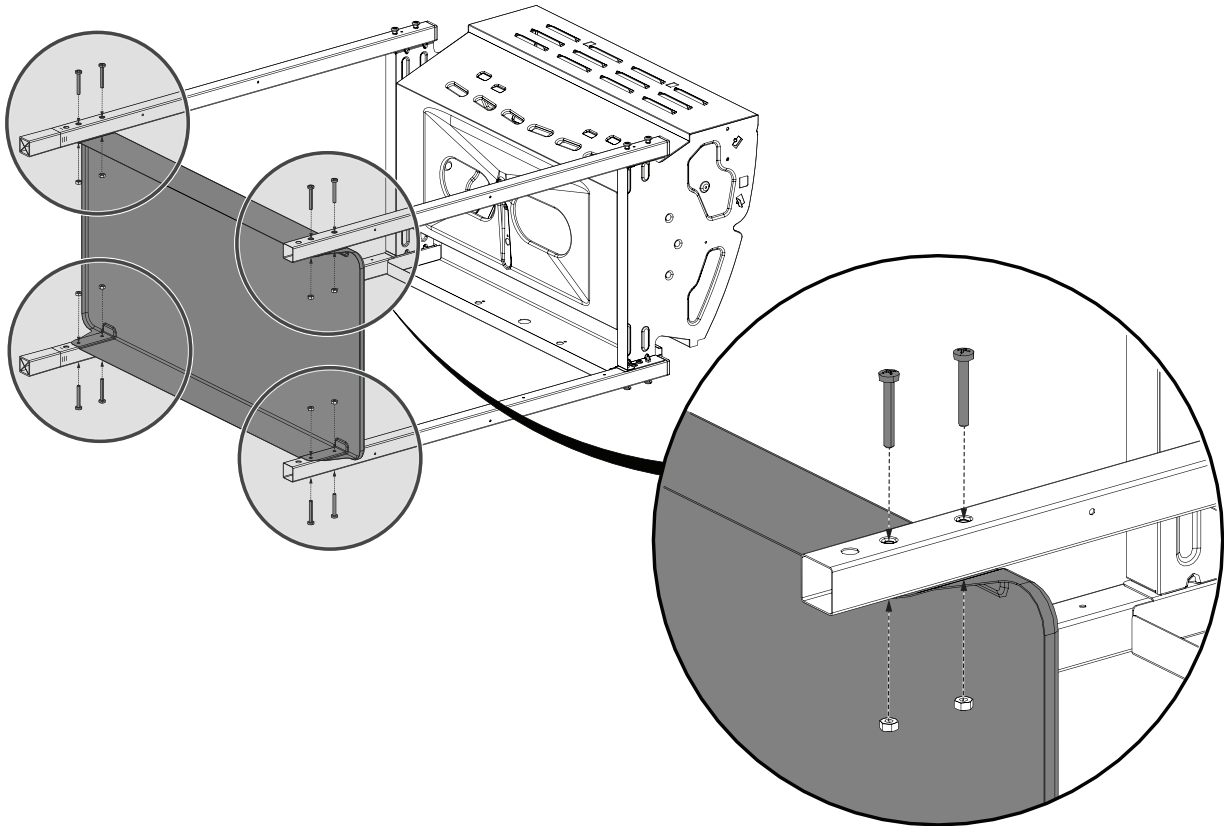

07

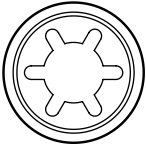

X 1

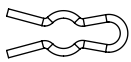
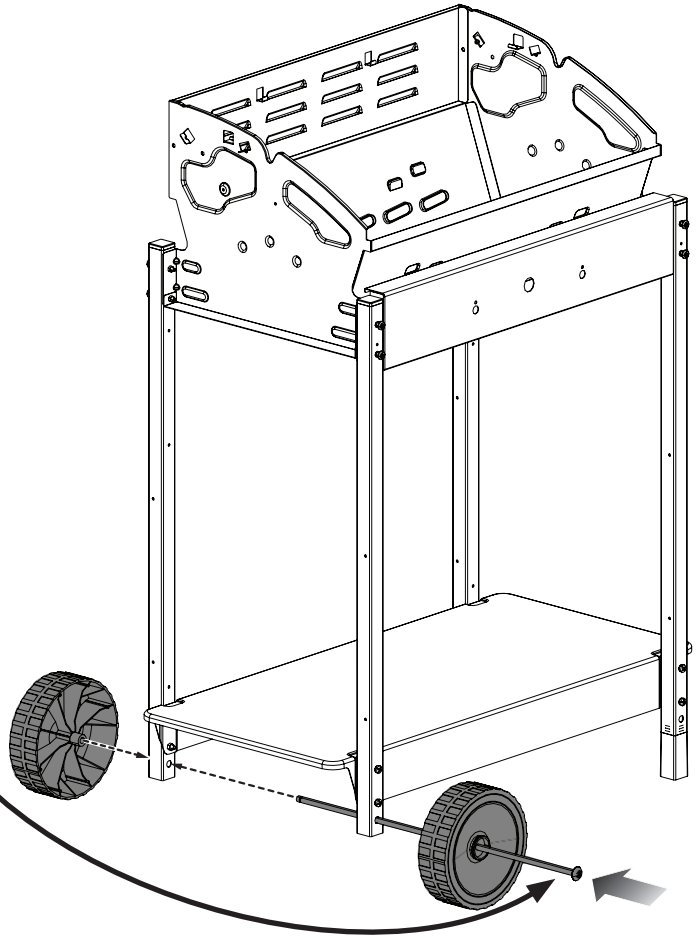
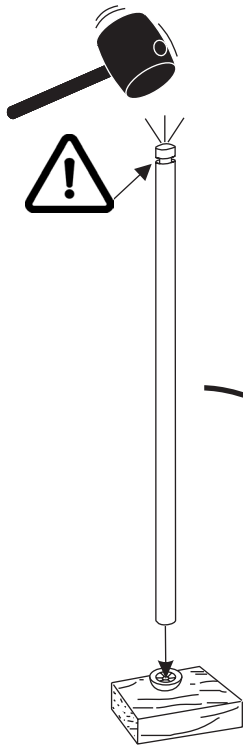

X 1

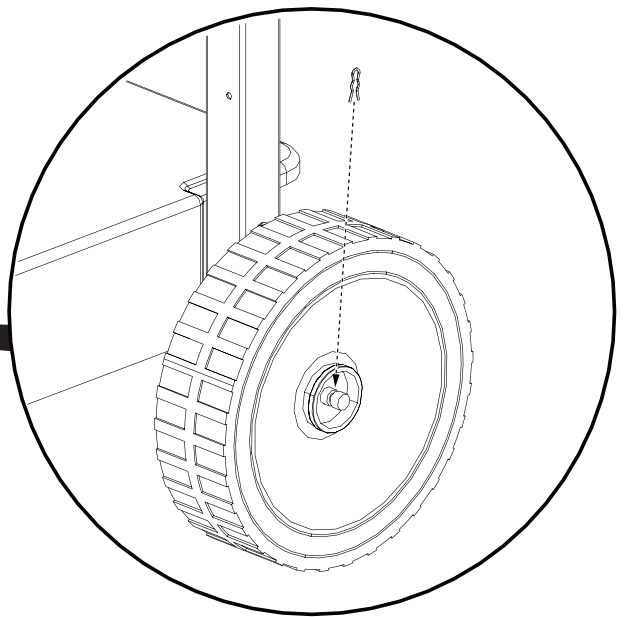
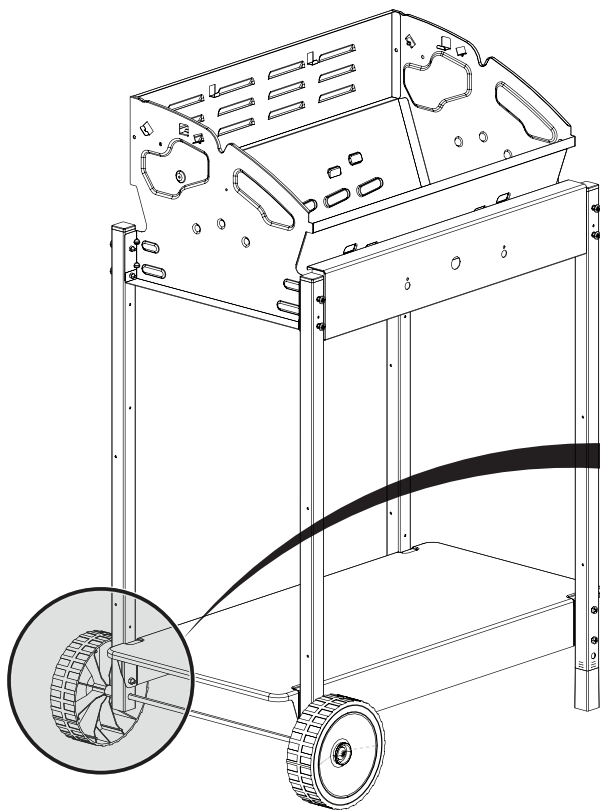

08

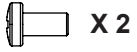

X 2

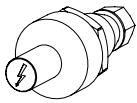
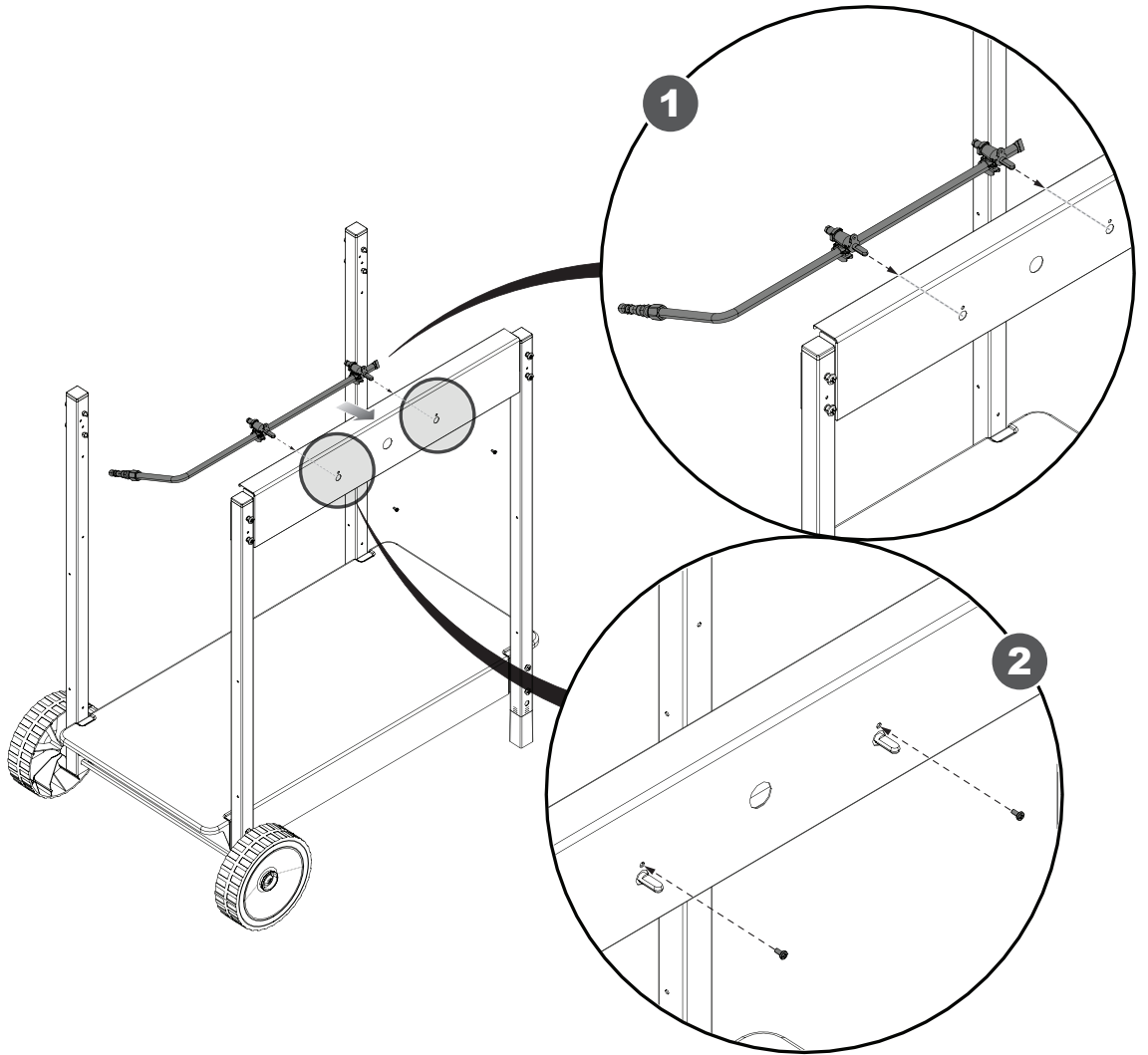

X 1

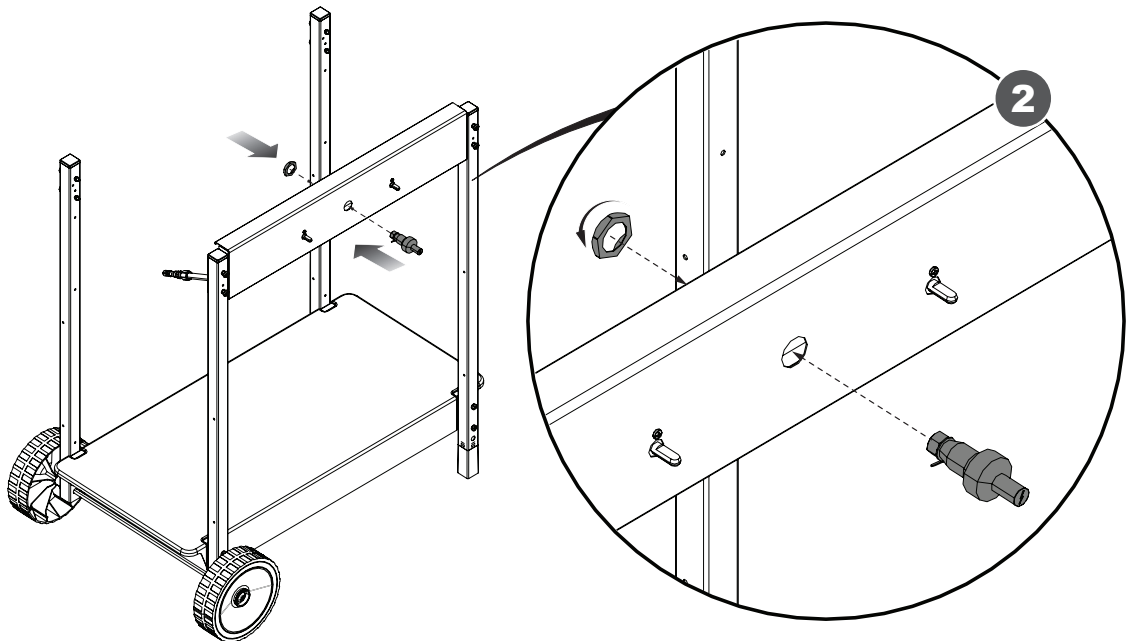
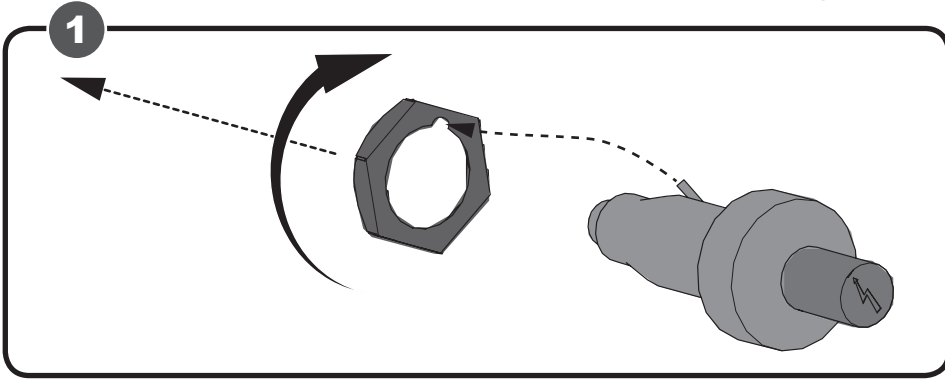

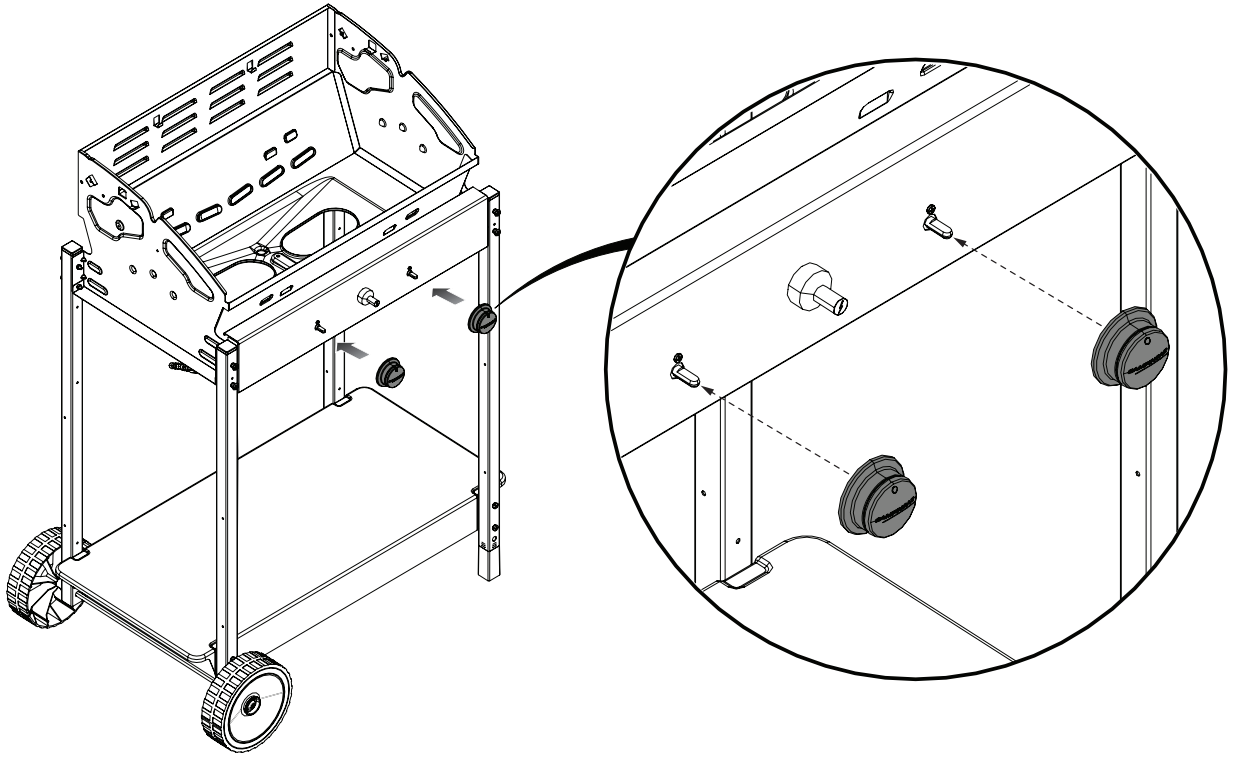

09

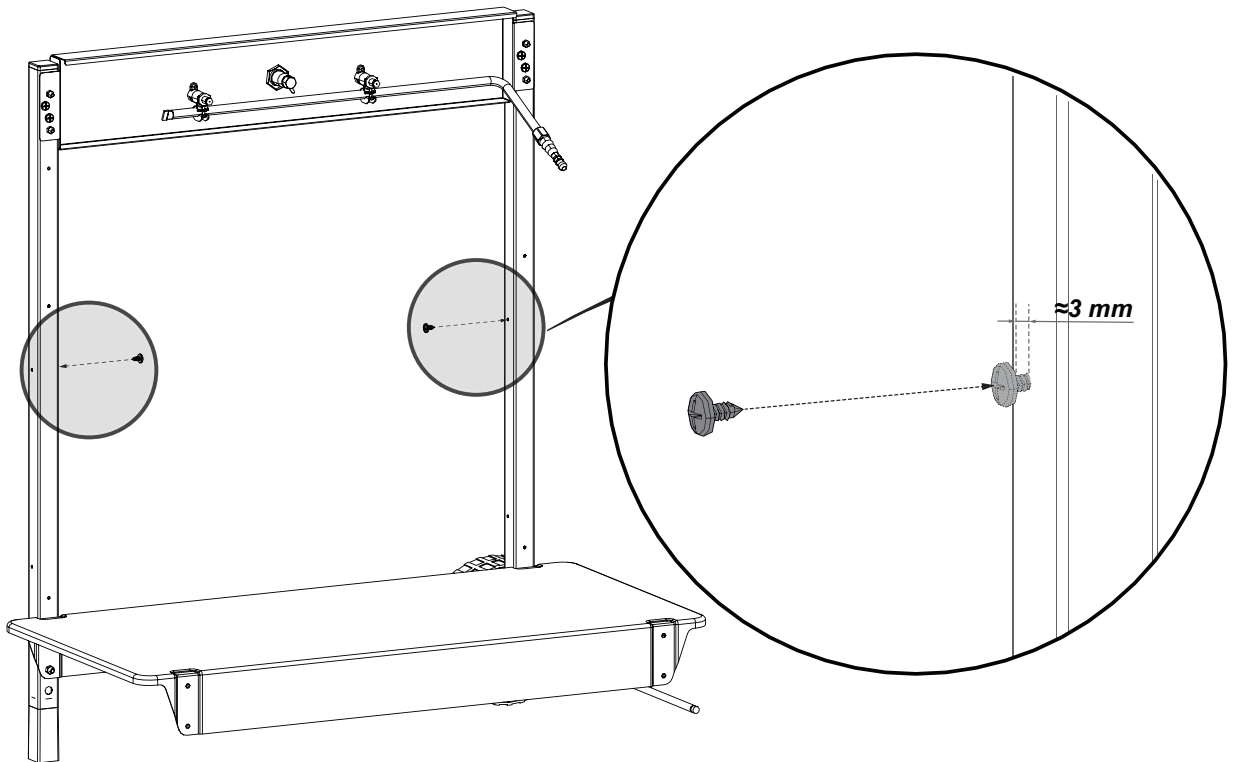
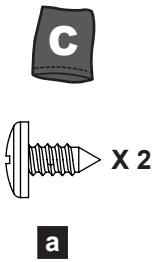

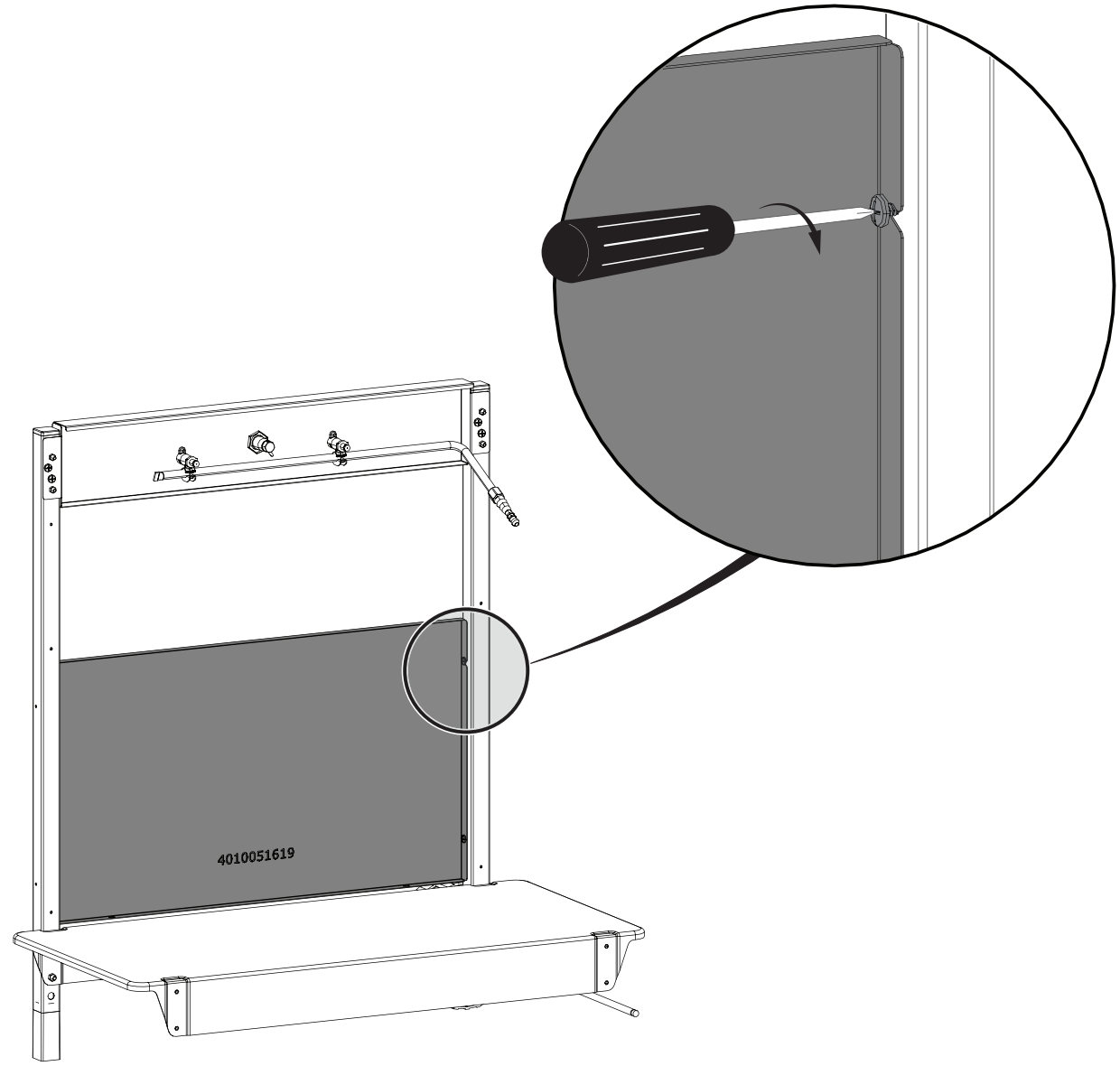
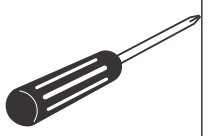
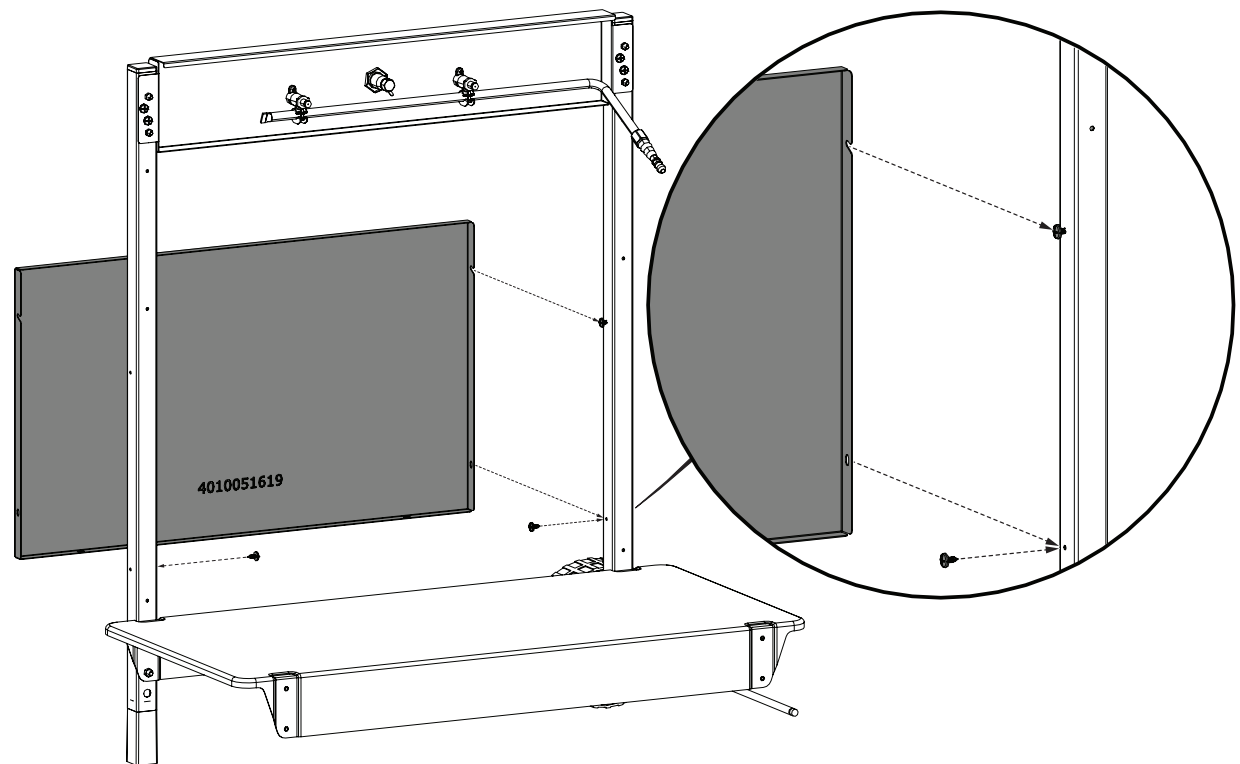
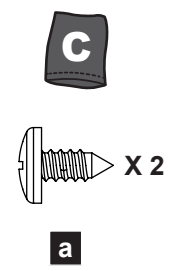

10

A

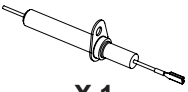

X 1

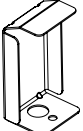

X 1

C

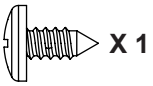





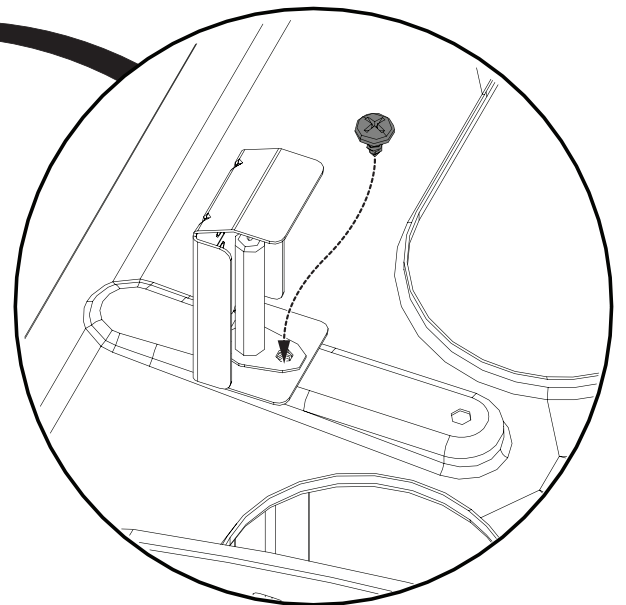
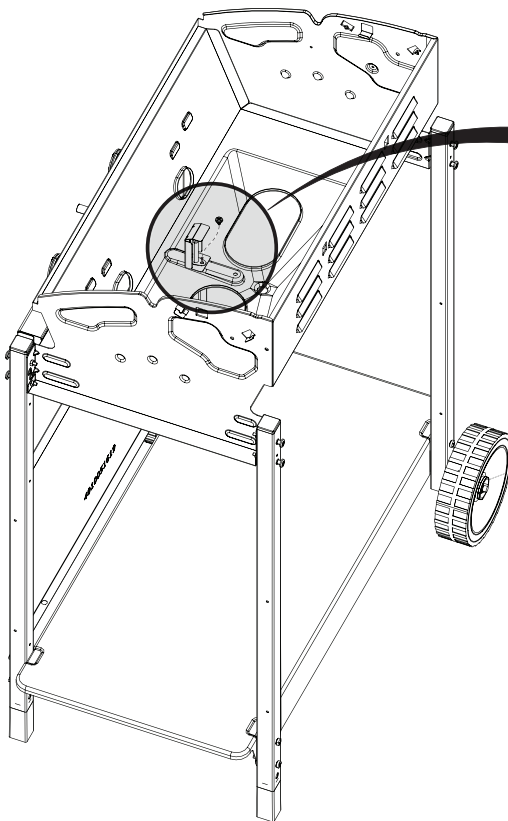
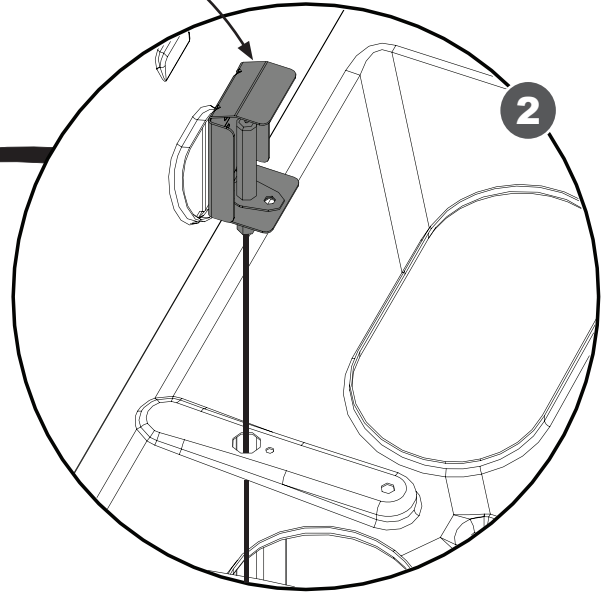
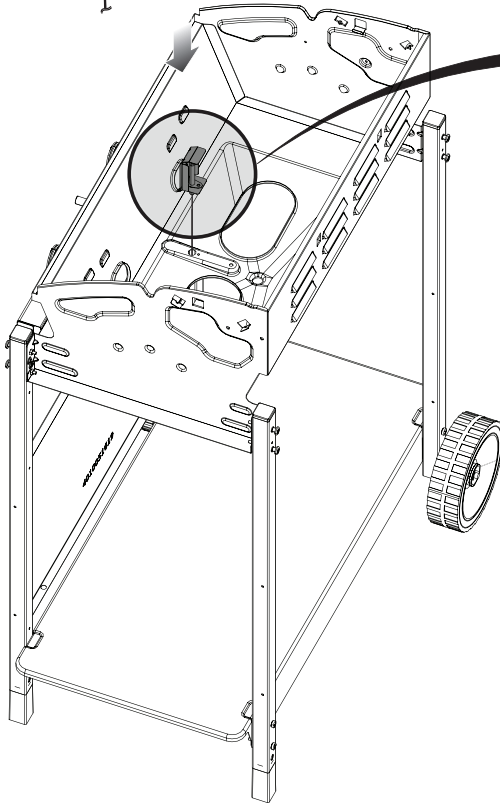
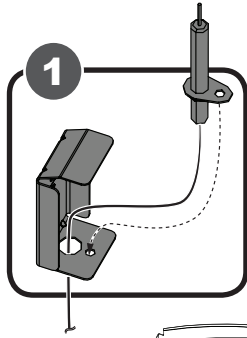

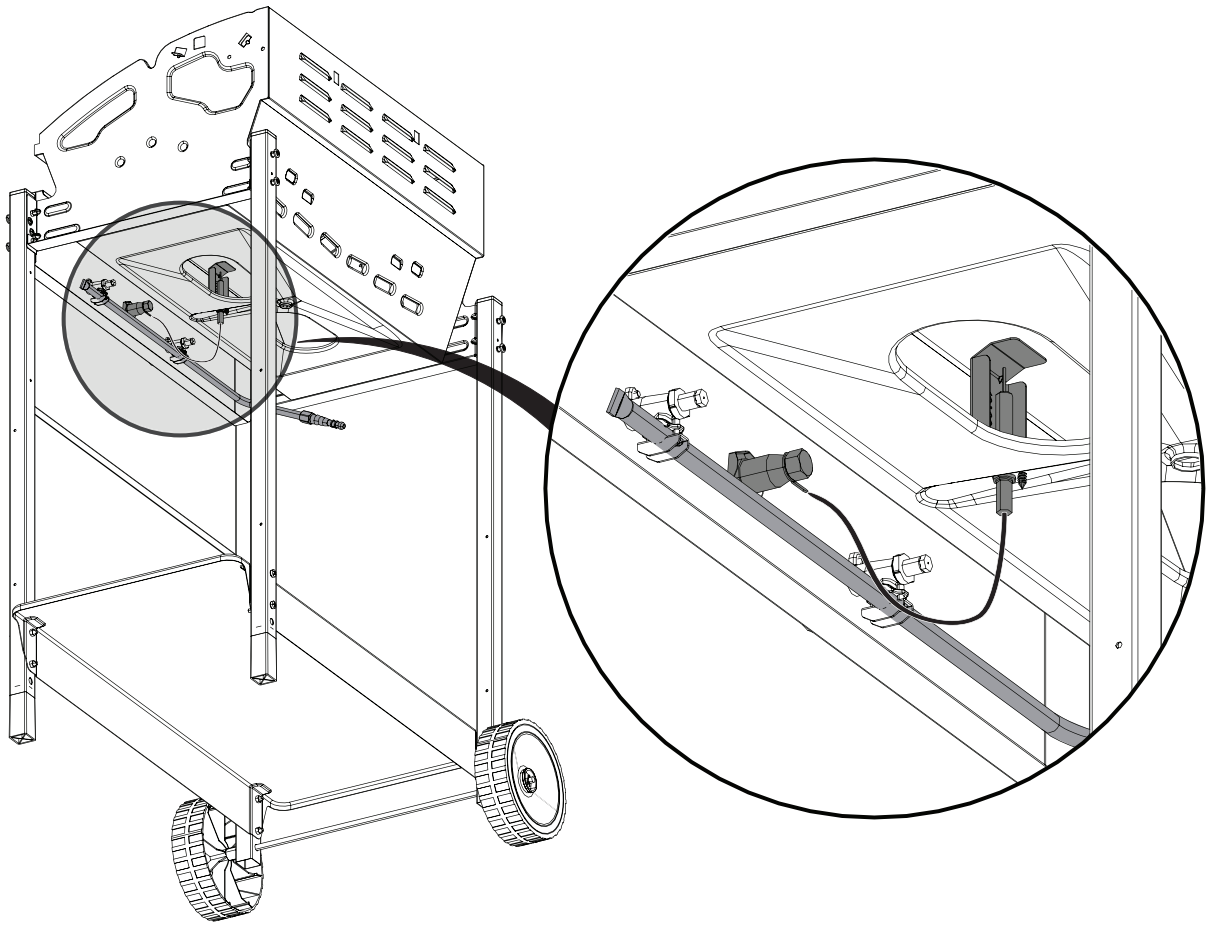
X 1

a





11

-  **C**
-  **X 1**
-  **X 1**
-  **e**
-  **X 1**
-  **n**
-  **8**

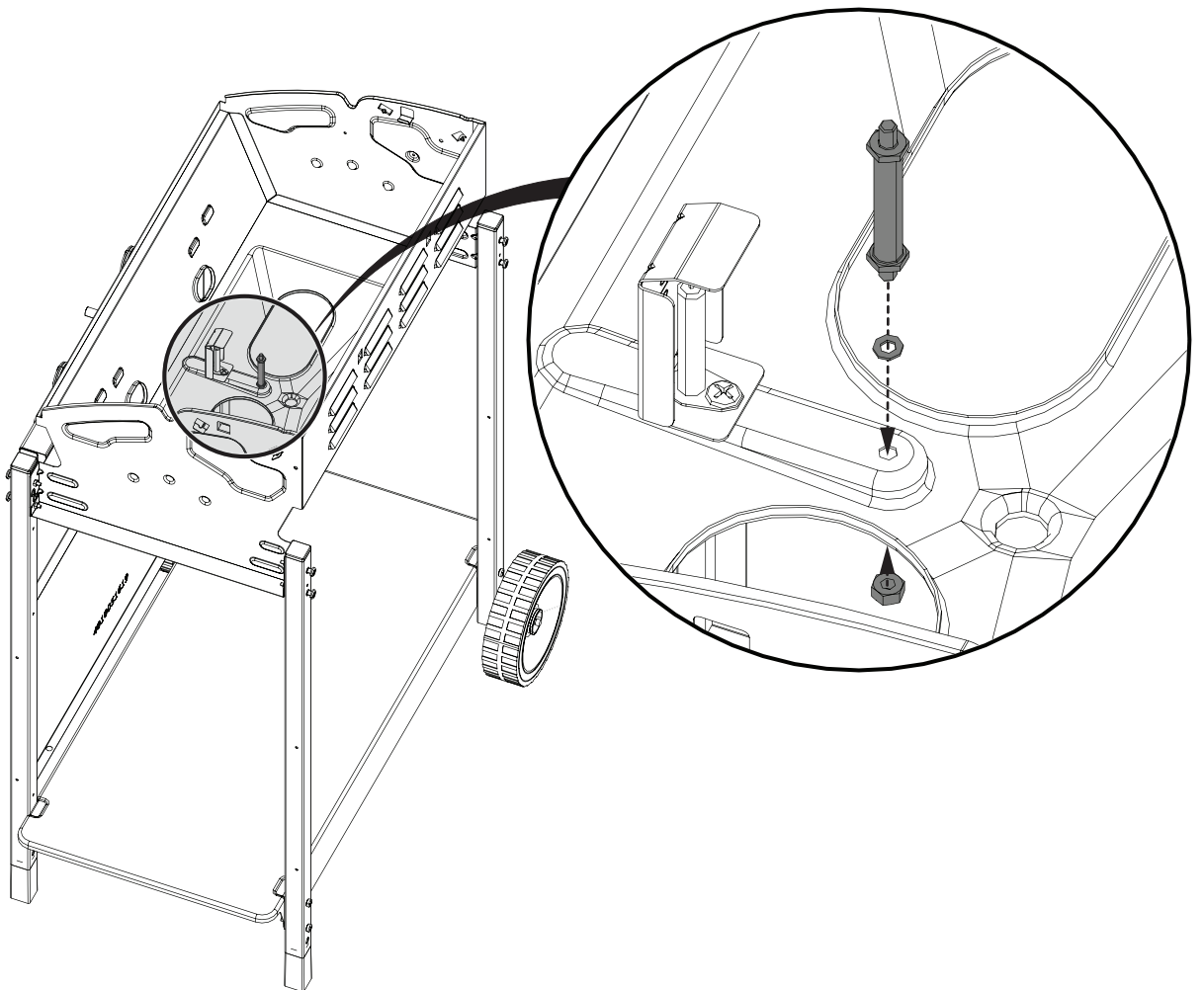

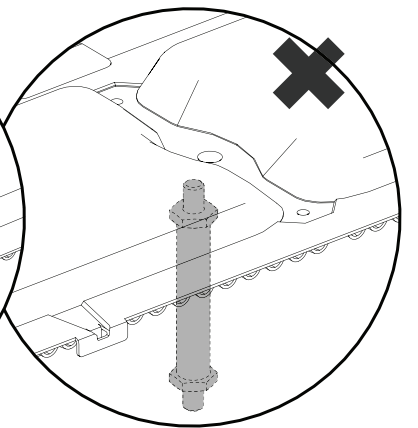
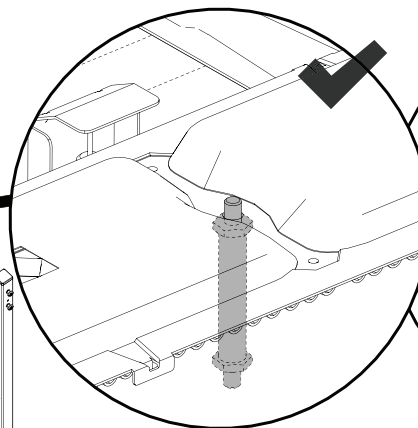
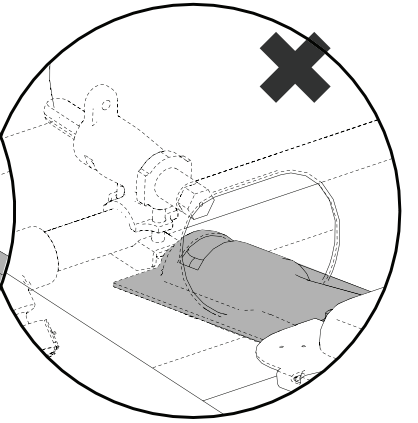
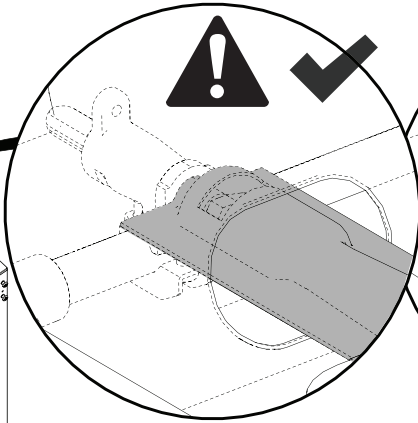
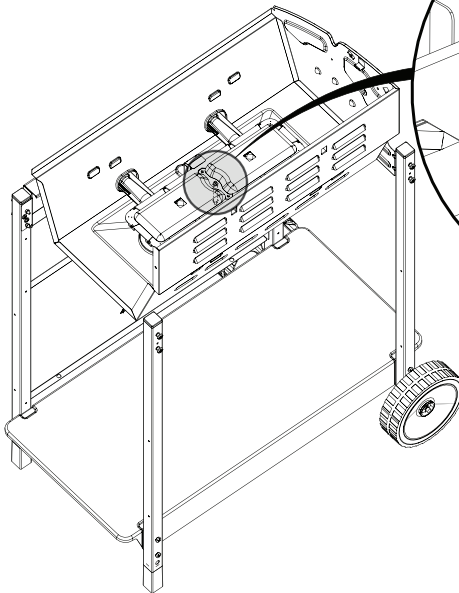
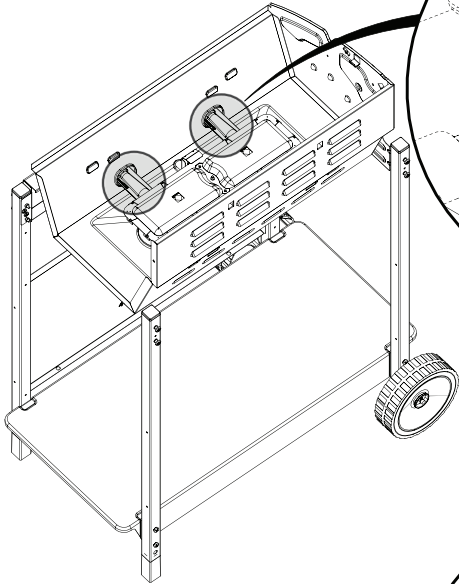
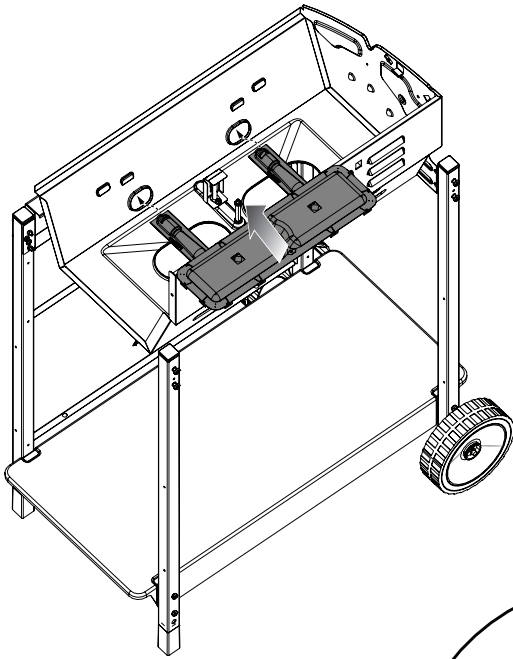

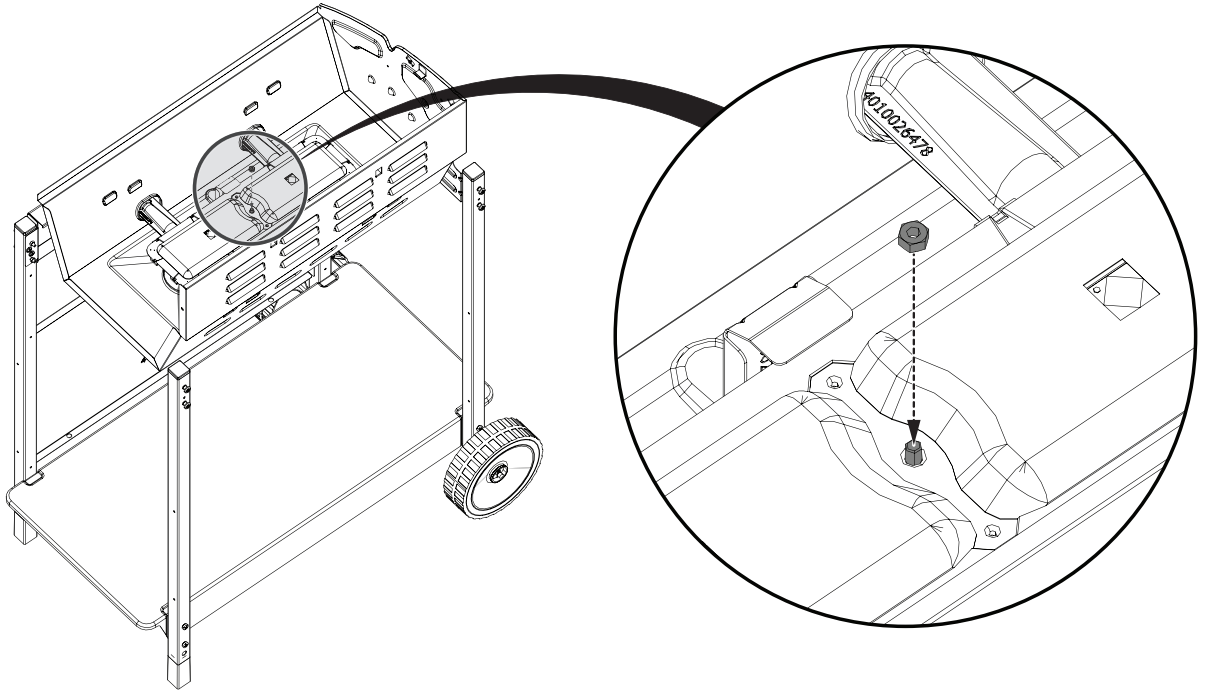
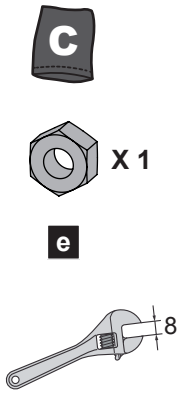



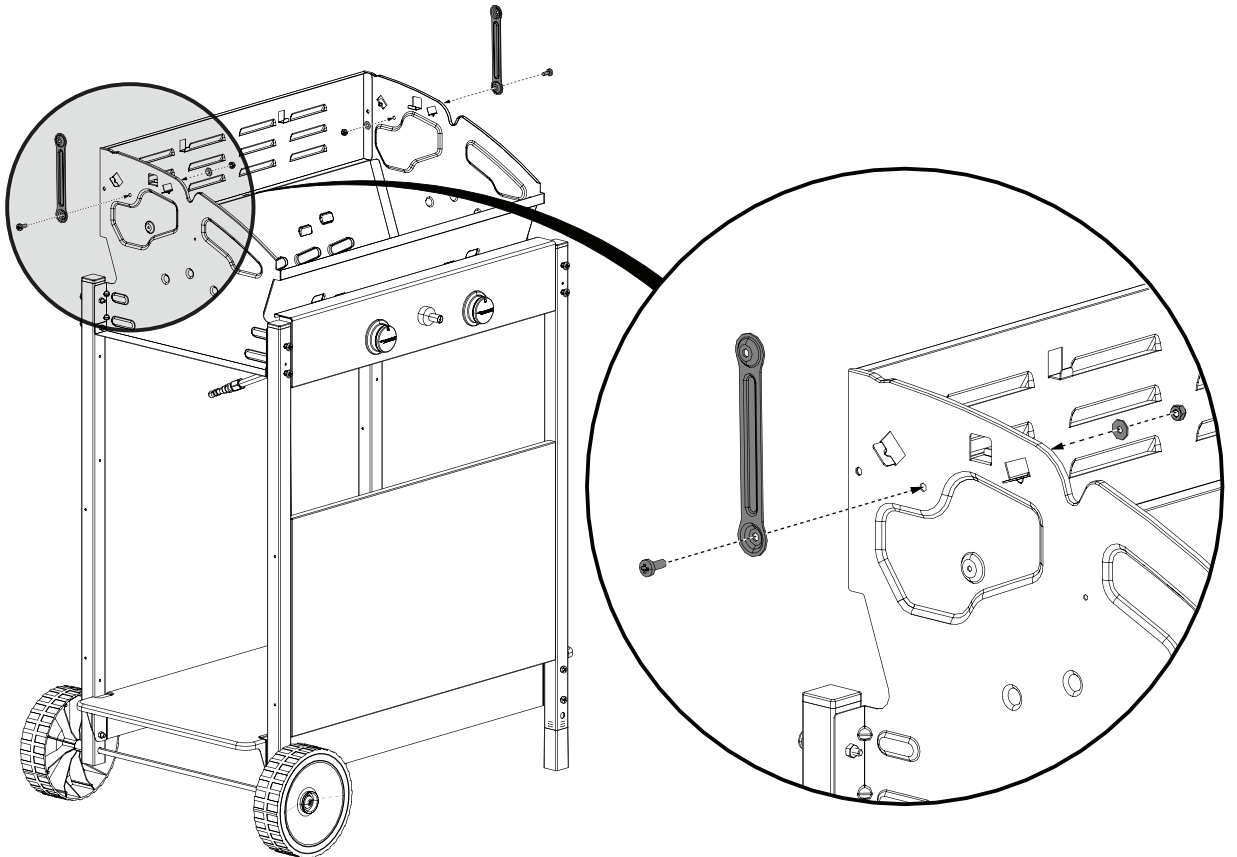
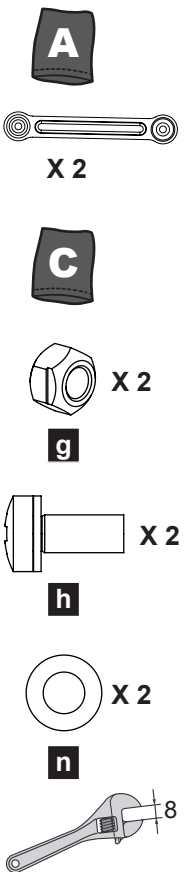





13

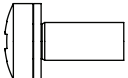

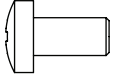

14

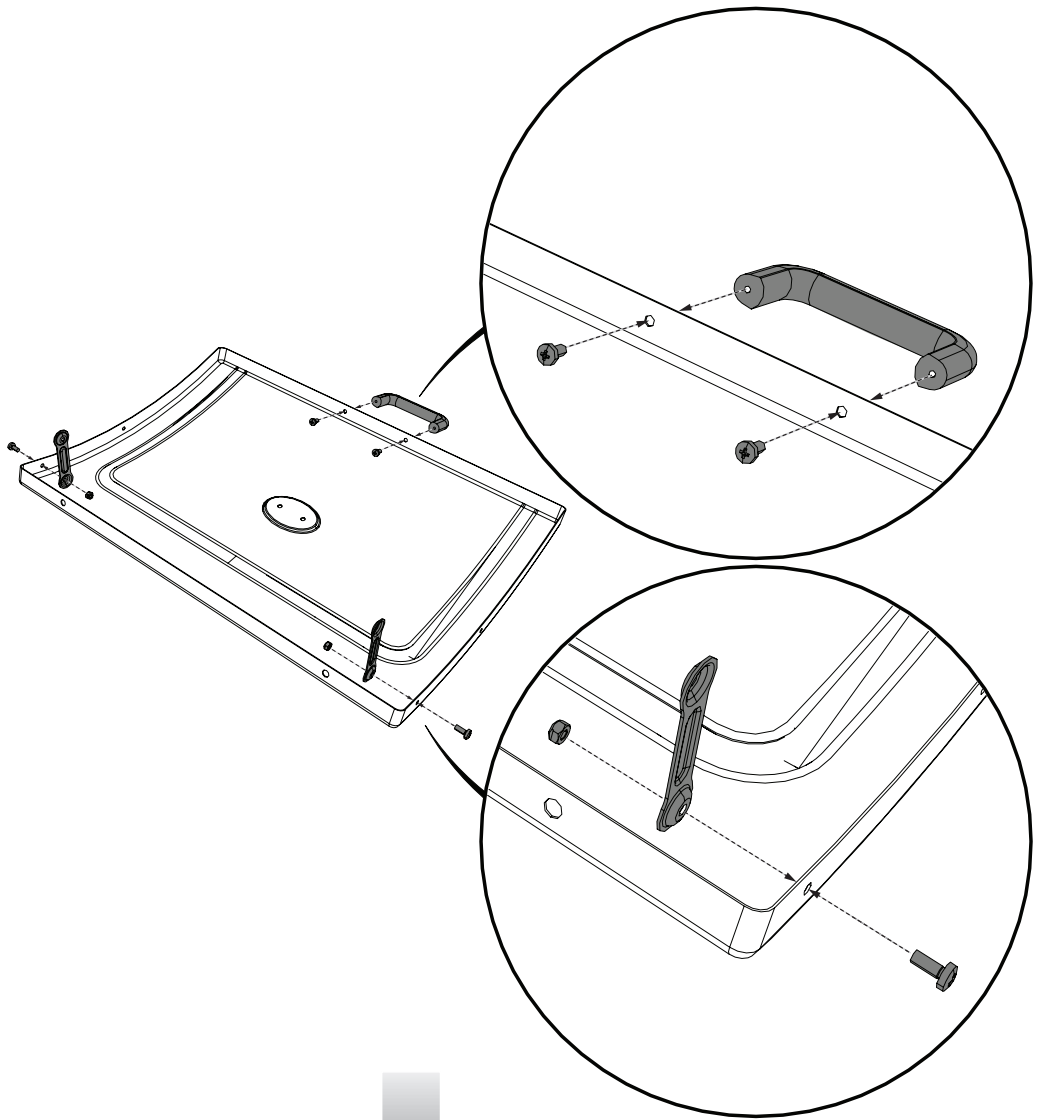
- **A**
- **X 2**
- **C**
- **X 2**
- **g**
- **X 2**
- **h**
- **X 2**
- **i**
- **8**



Option

- **A**
- **X 1**
- **8**

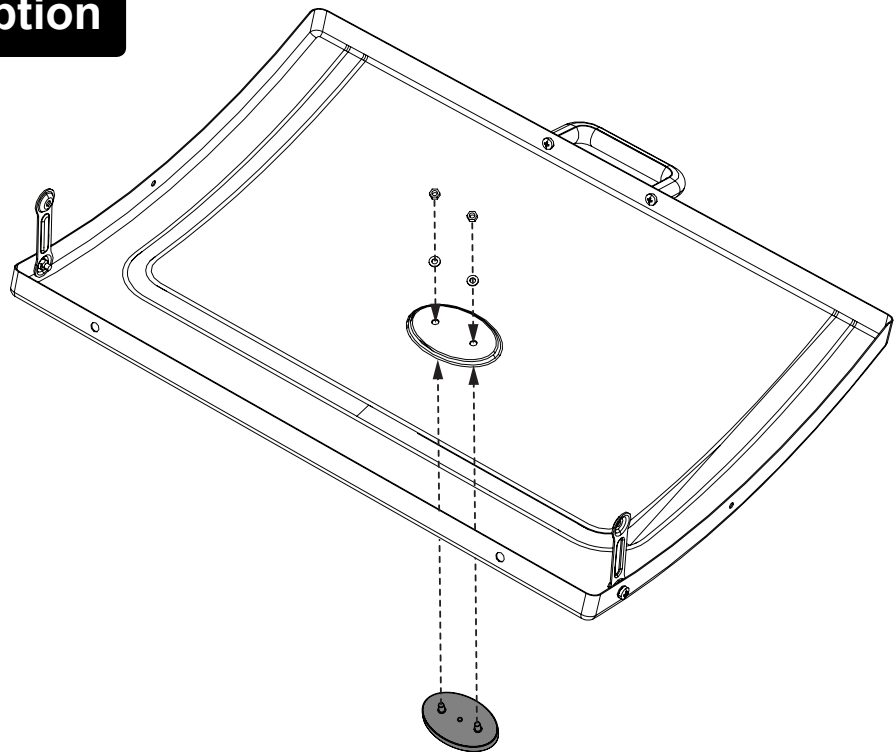

15

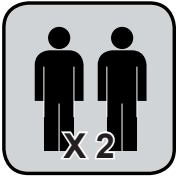

g

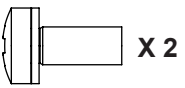

h

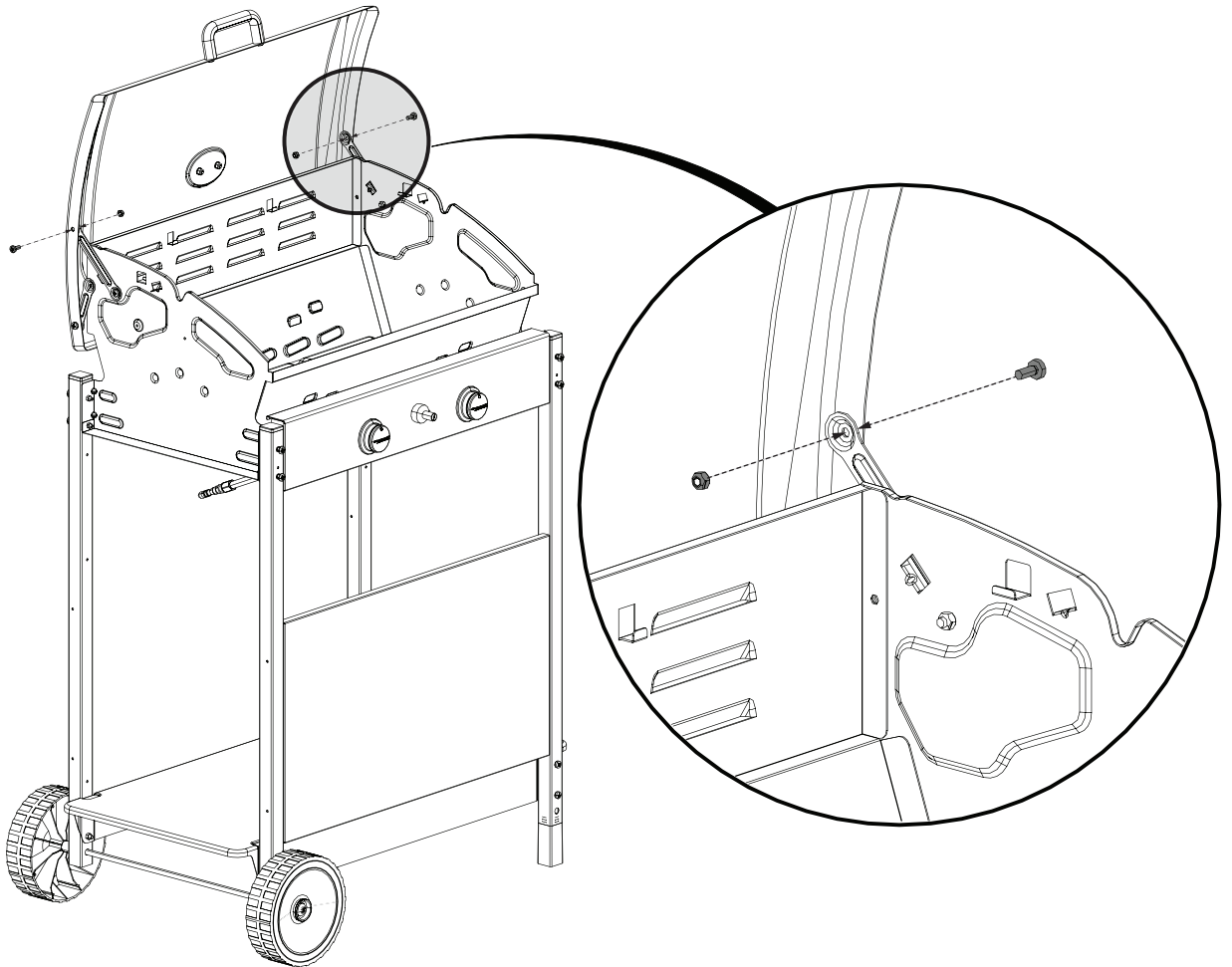

g

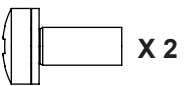

h



n

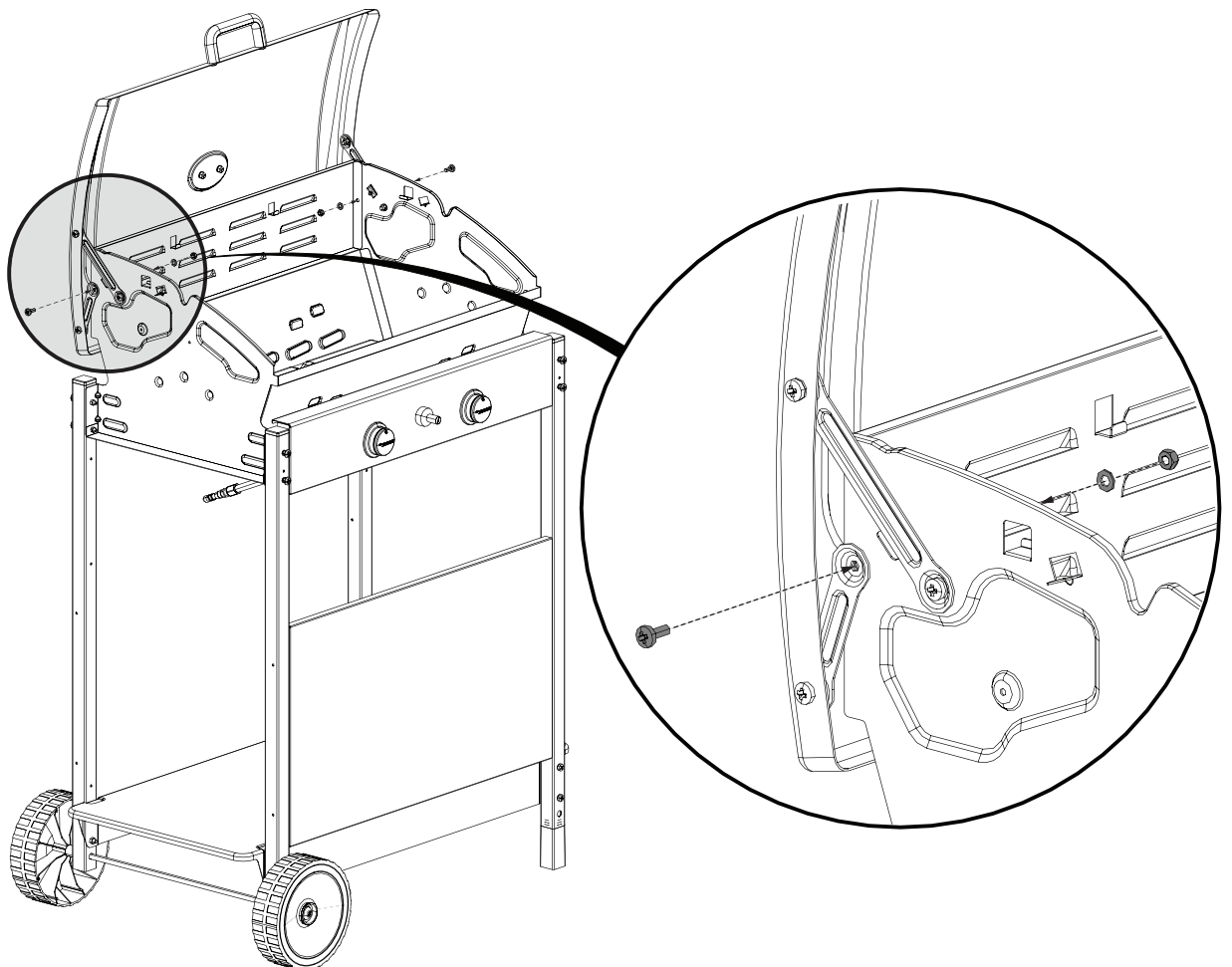

16

C

X 2

a

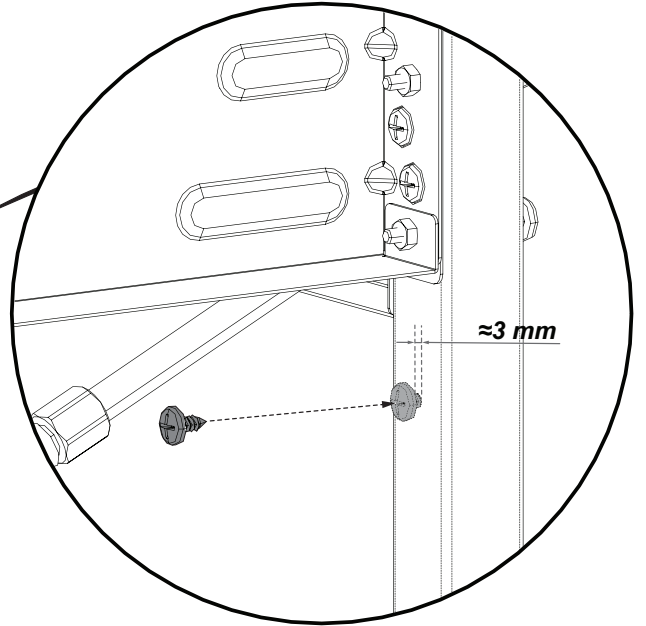
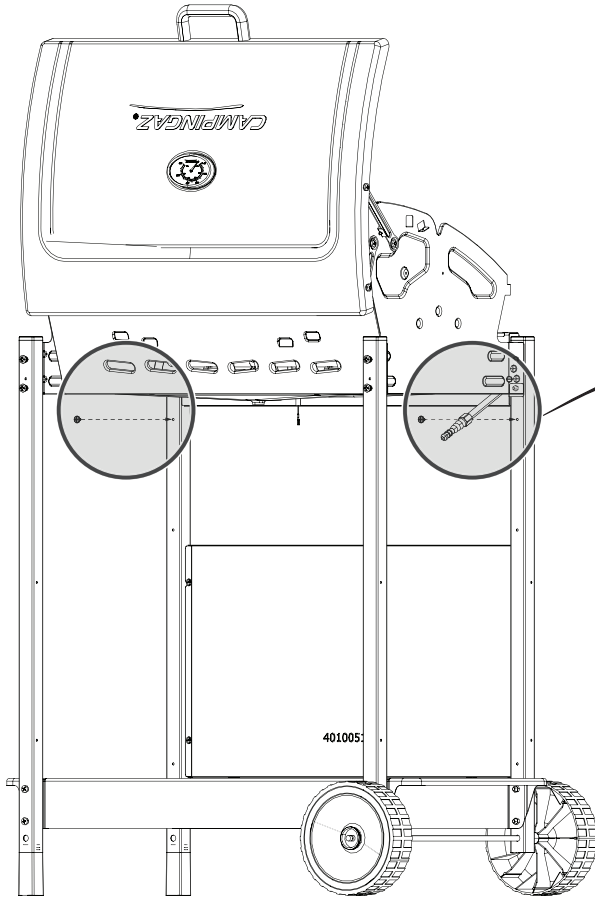

C

X 2

a

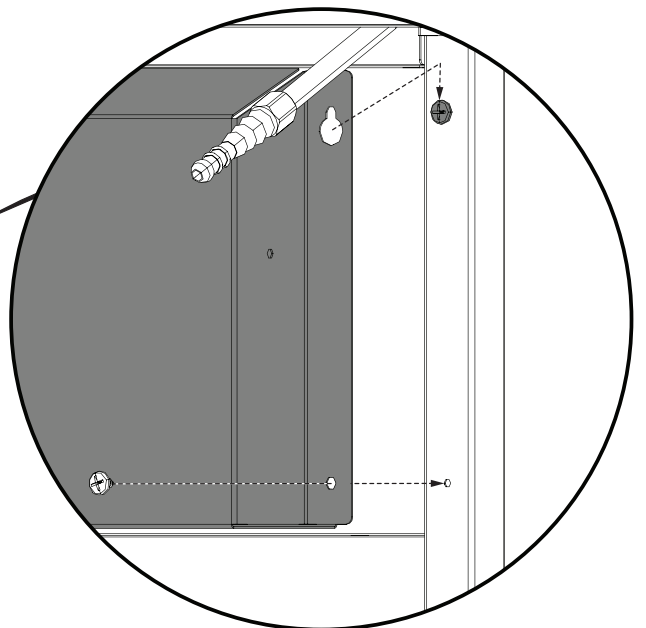
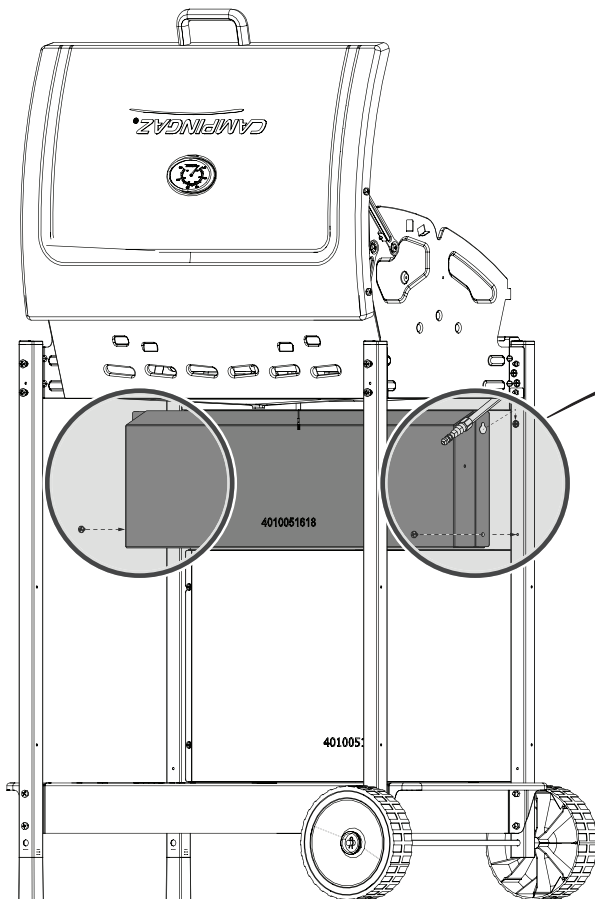

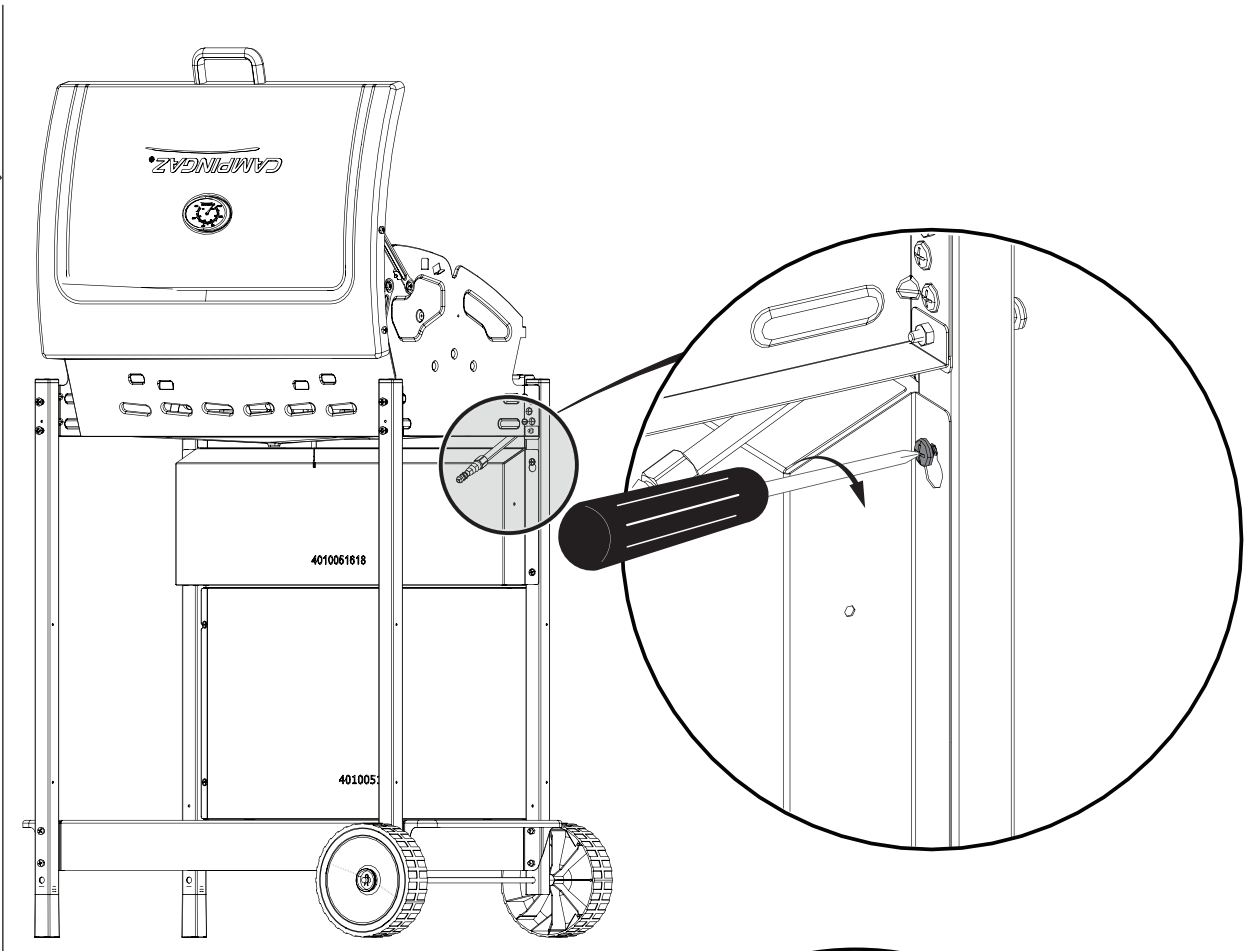
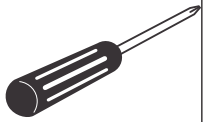

17

- A**
- B**
- C**
- D**
- E**
- F**
- G**
- H**
- I**
- J**
- K**
- L**
- M**
- N**
- O**
- P**
- Q**
- R**
- S**
- T**
- U**
- V**
- W**
- X**
- Y**
- Z**

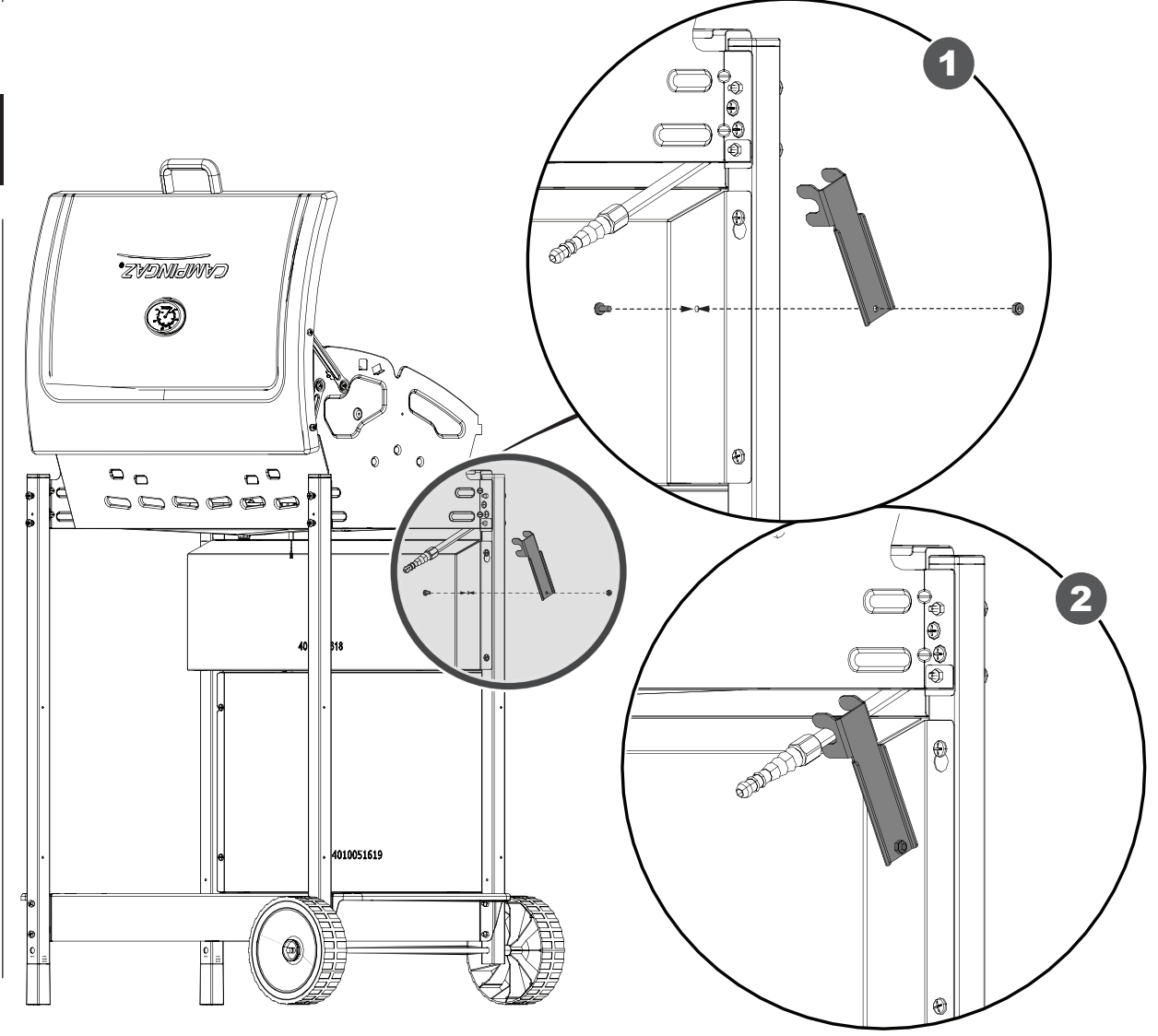

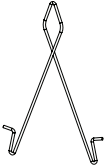

X 1

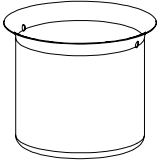

X 1

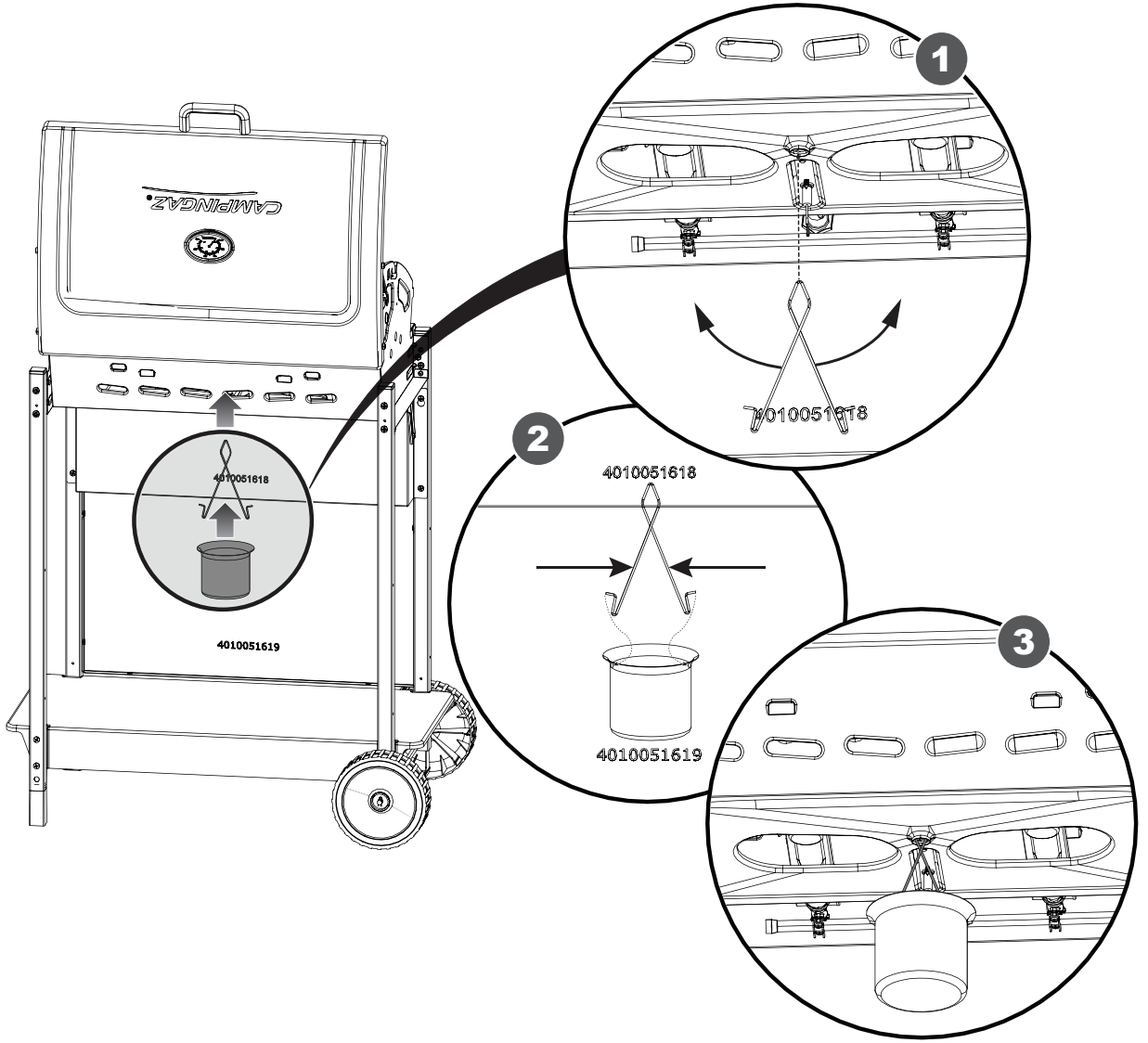



Xpert 200 L • Xpert 200 L+
Xpert 200 L Rocky • Xpert 200 L+ Rocky

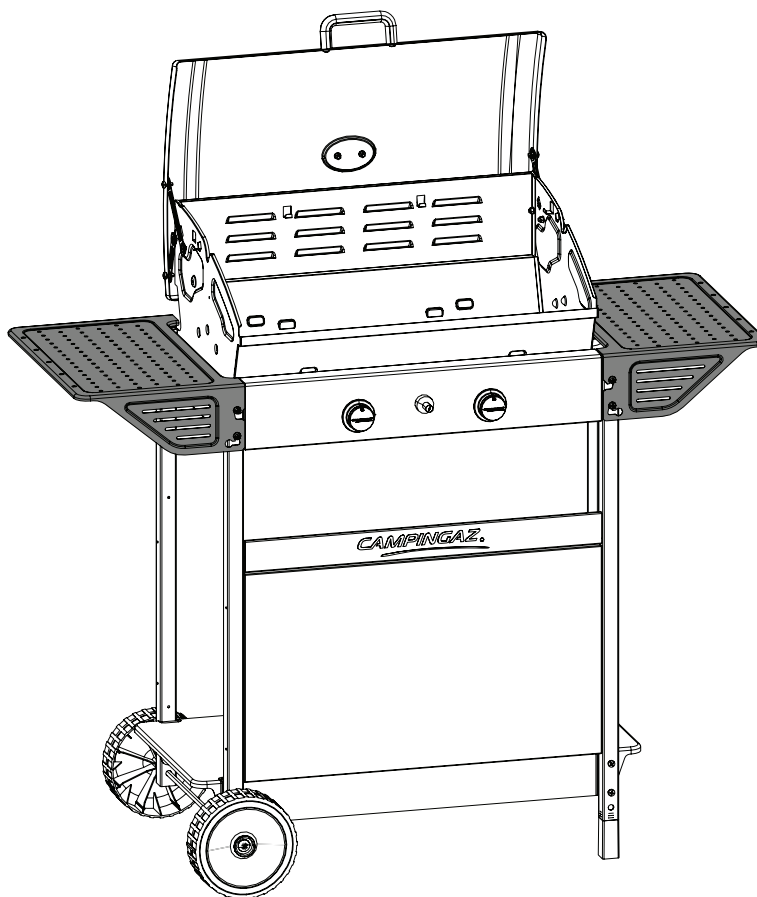
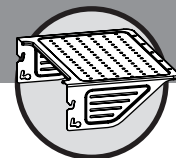

P24



Xpert 200 LW
Xpert 200 LW Plus Vario

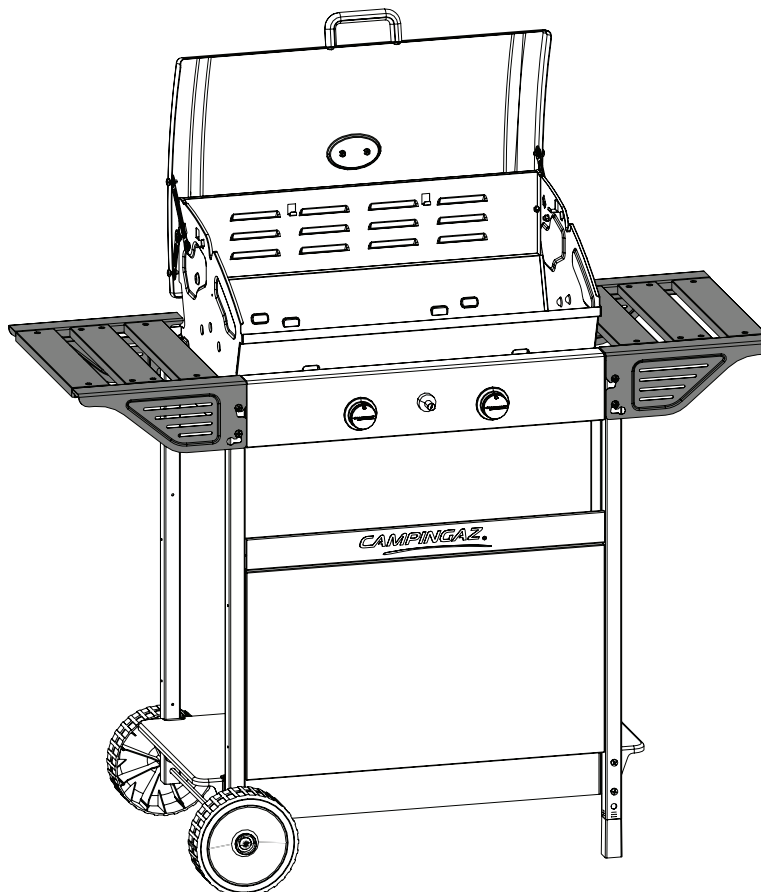
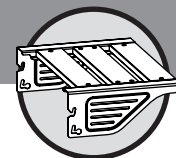

P25

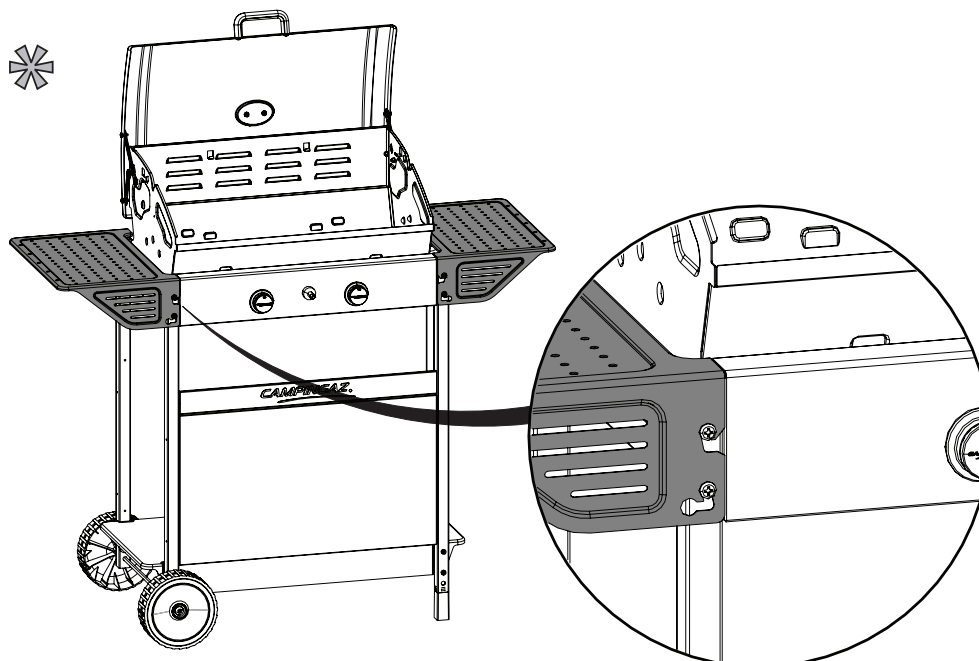
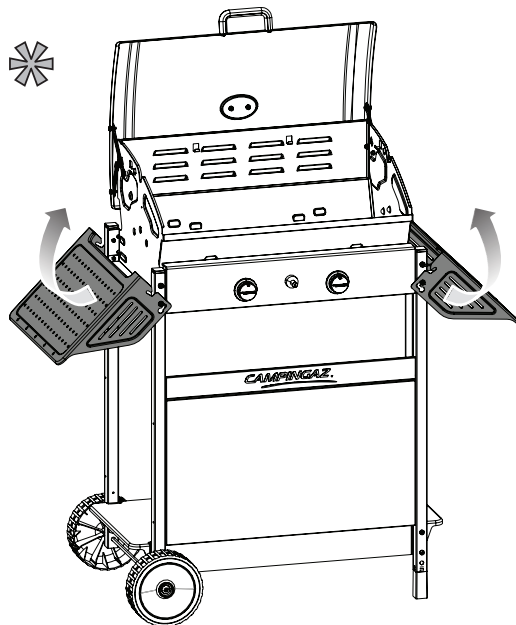
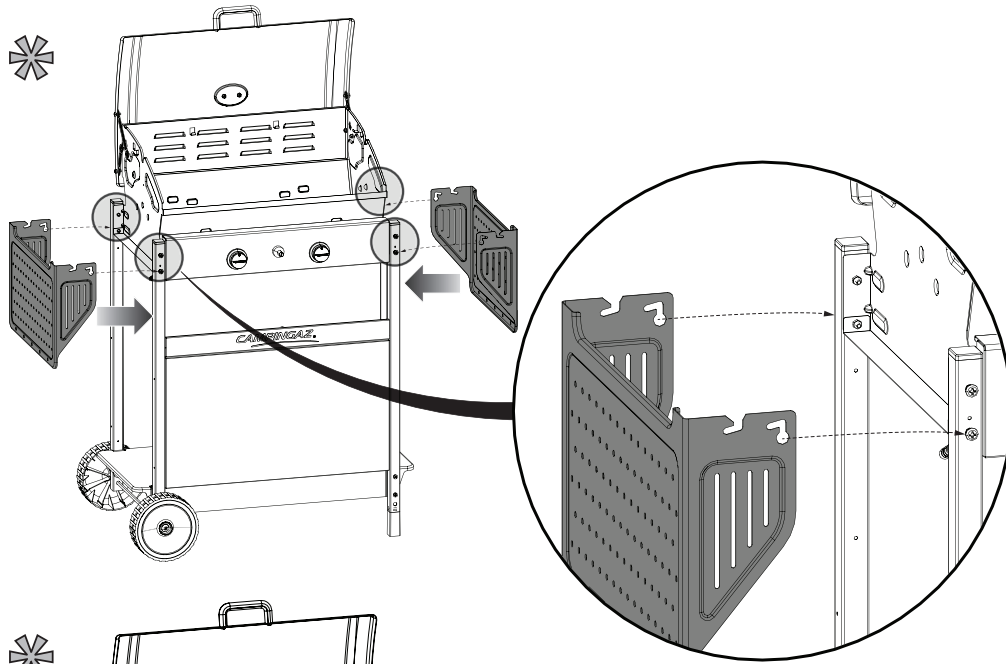
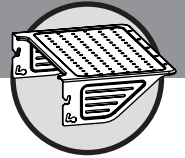

(Continued on Page 26)

*19



Xpert 200 LW Xpert 200 LW Plus Vario

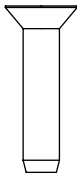
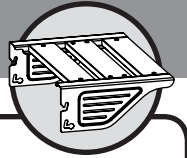

X 16

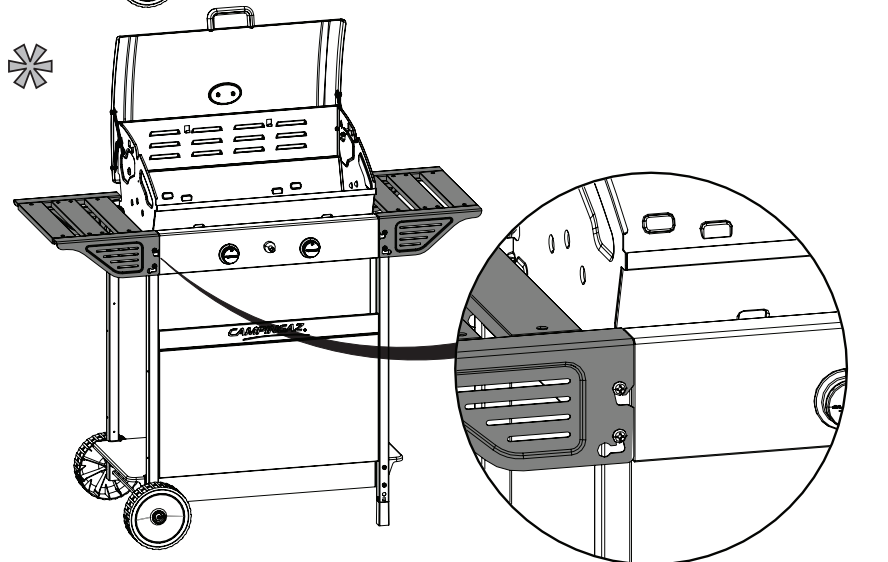
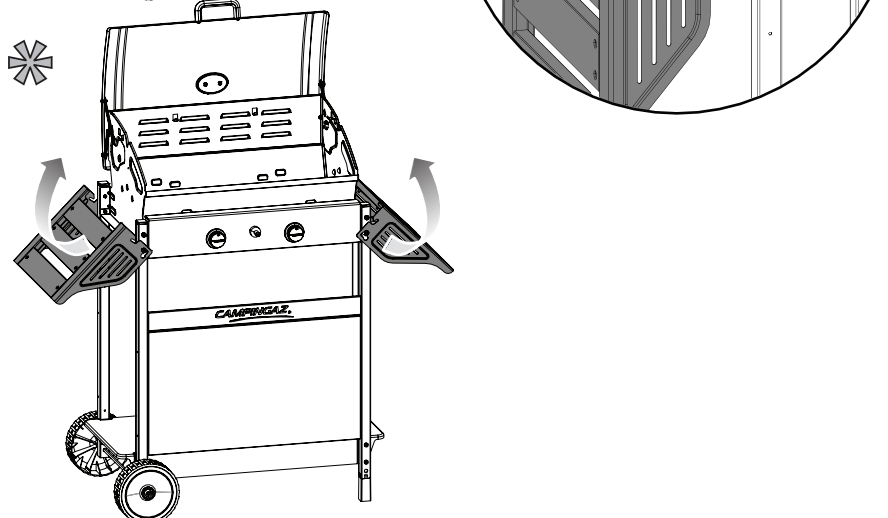
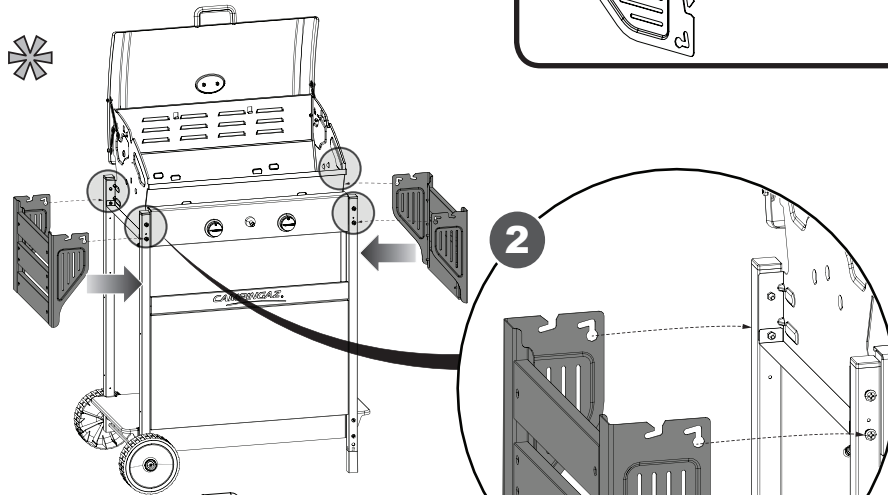
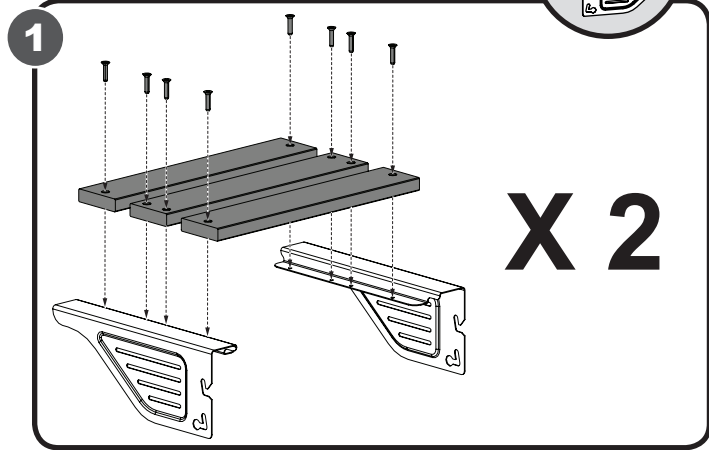

***20**



Xpert 200 L
Xpert 200 L+

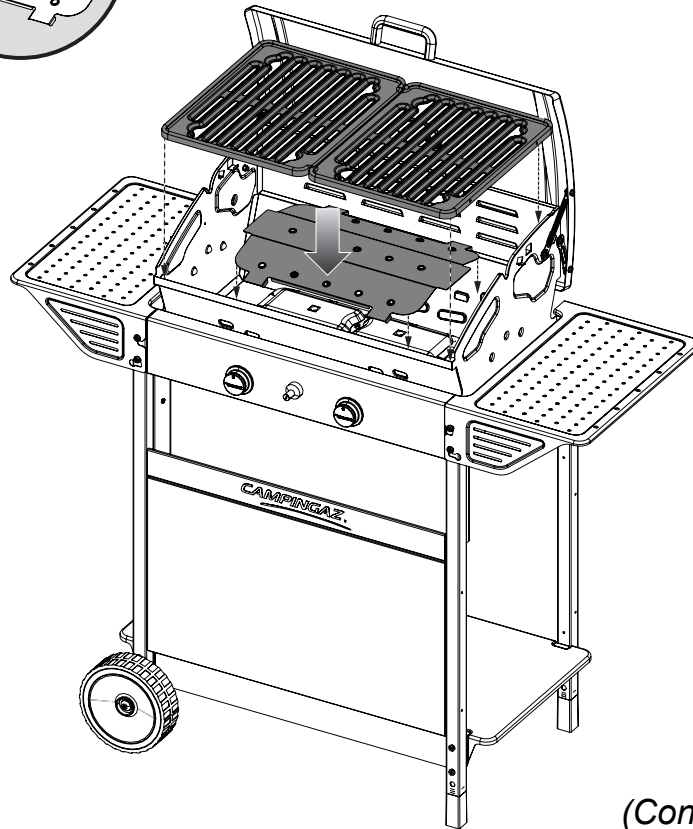
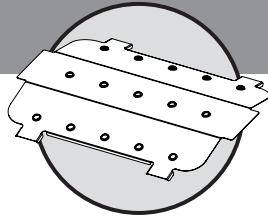

(Continued on Page 28)

***20**



Xpert 200 LW
Xpert 200 LW Plus Vario

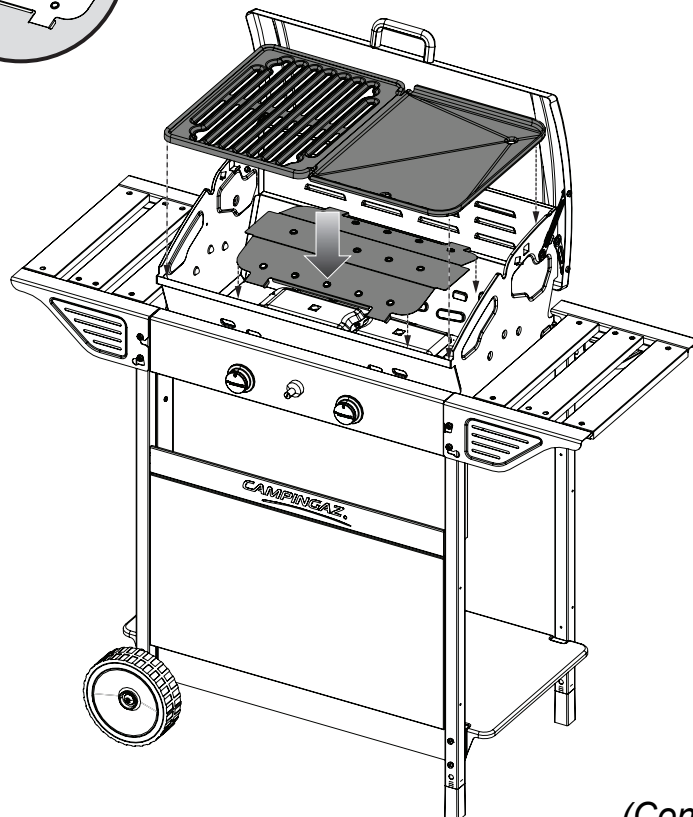
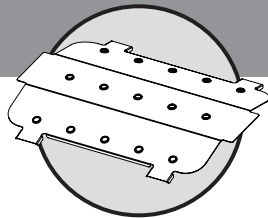

(Continued on Page 28)

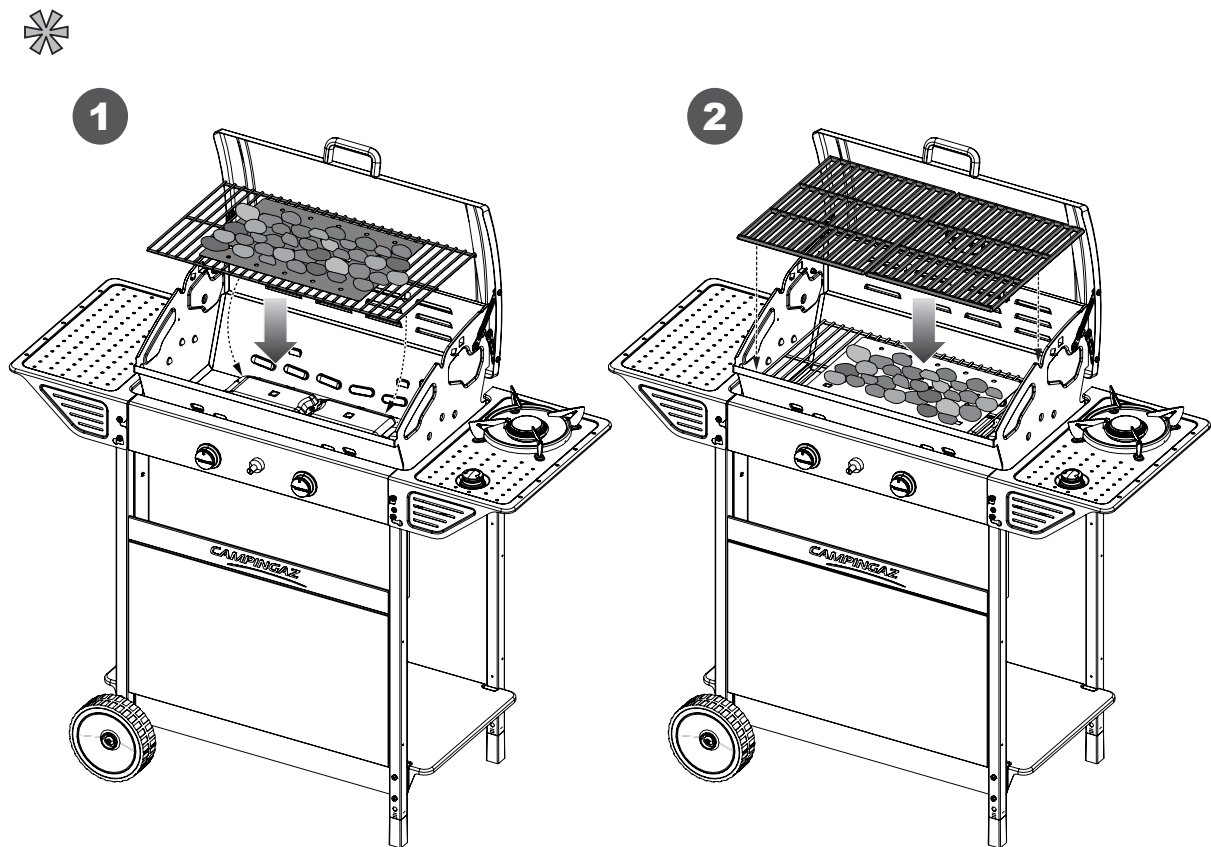
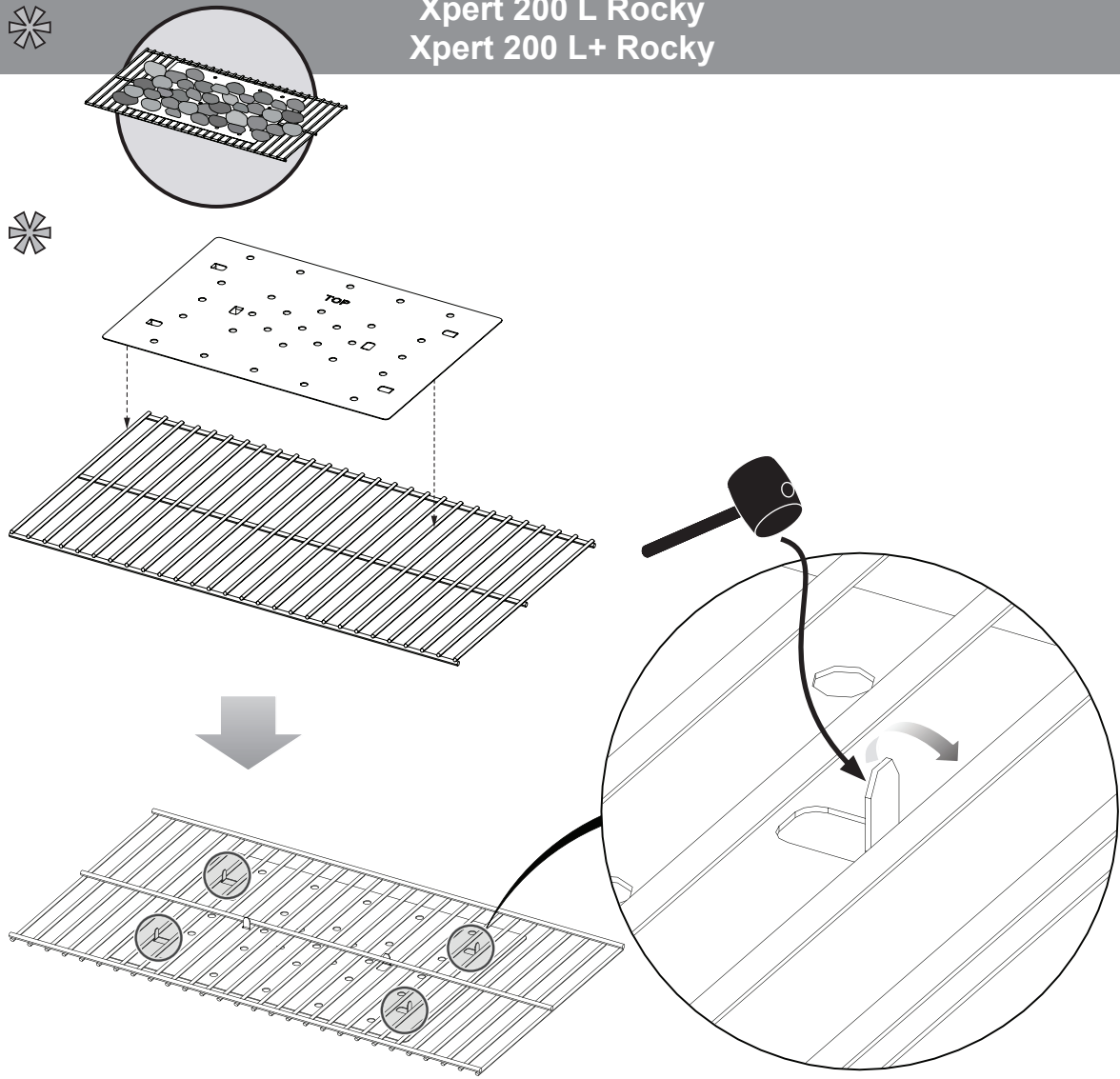

Option

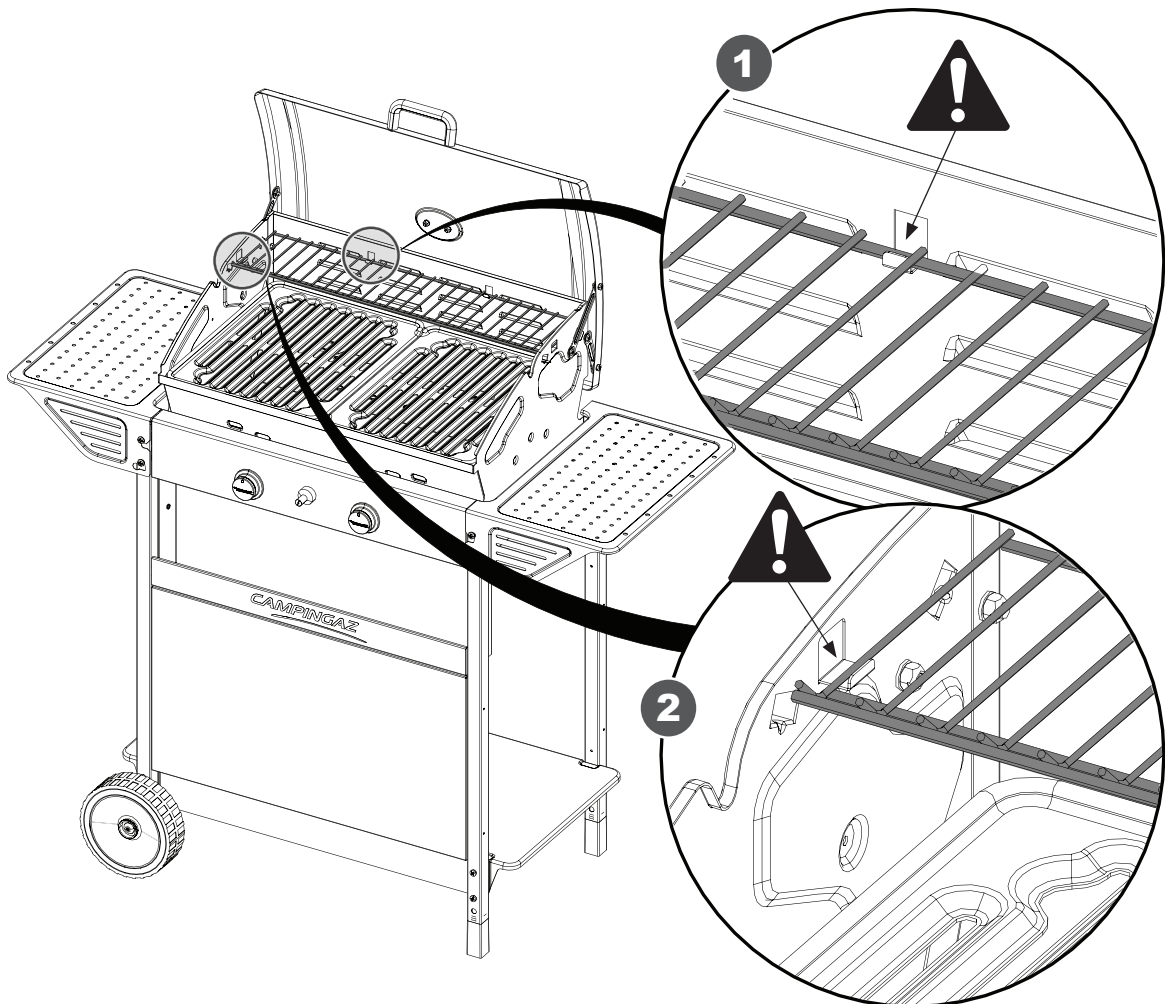
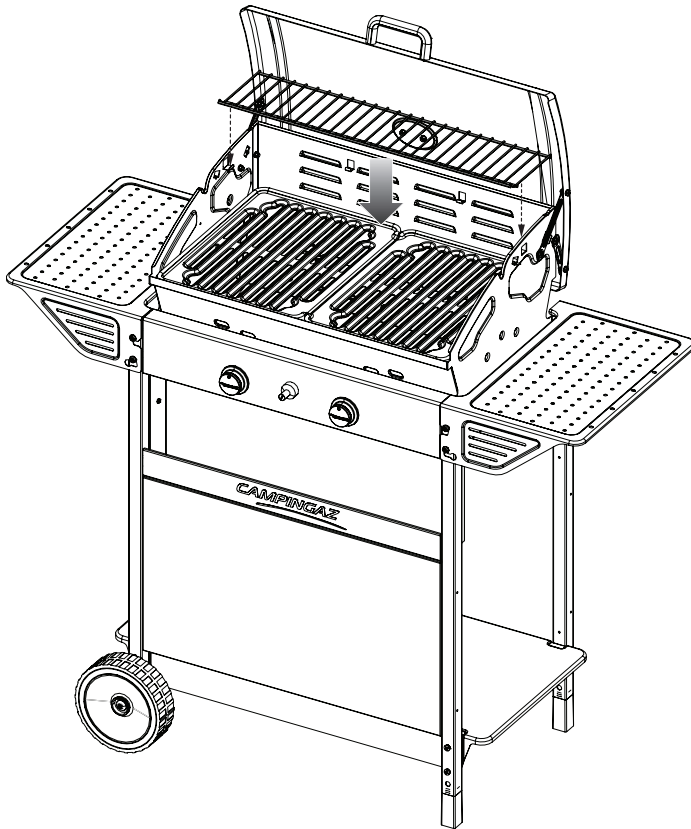

22

Option



X 5

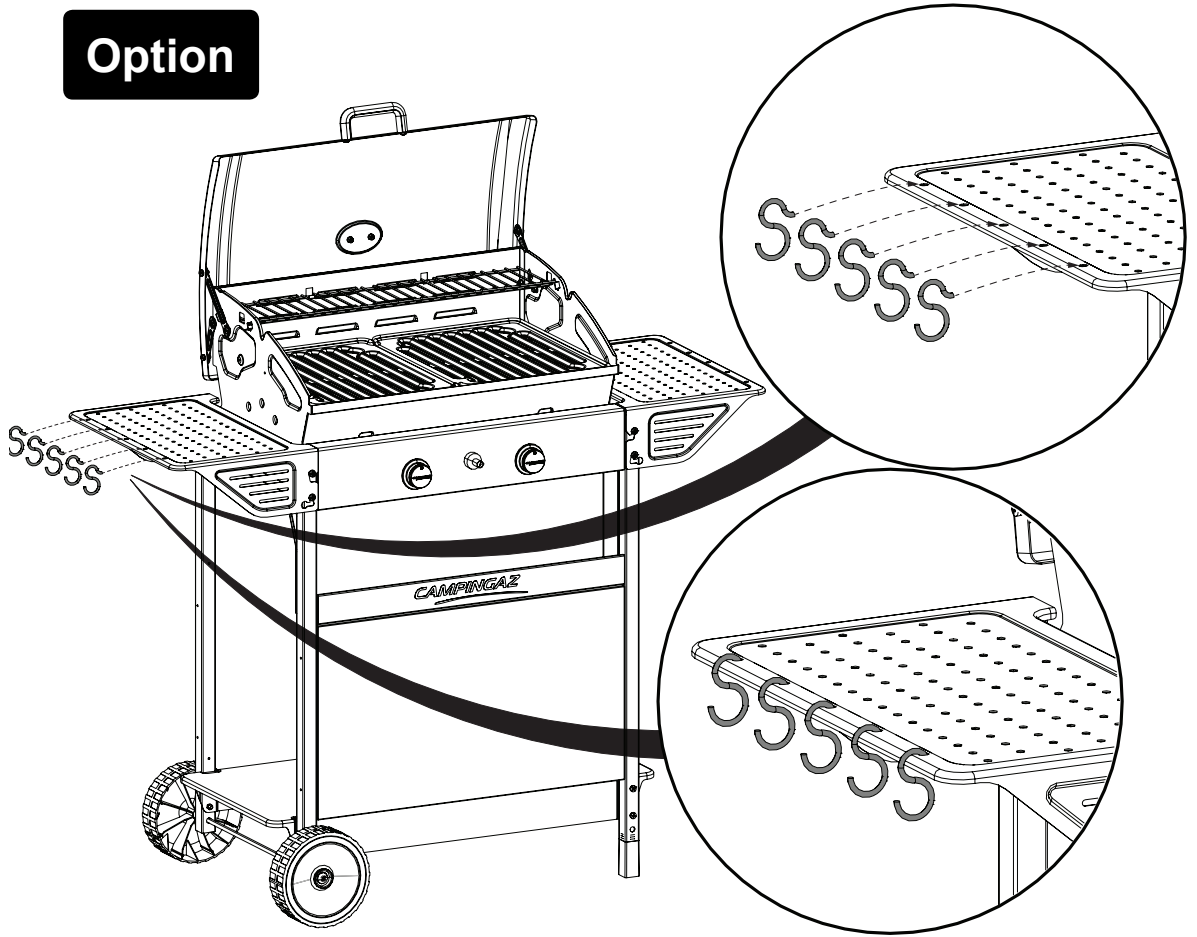

NOTES

NOTES

