

FR/ Annexe ES/ Apéndice PT/ Anexo IT/ Appendice
 EL/ Παράρτημα PL/ Załącznik RU/ Приложение UK/ Додаток
 RO/ Anexa EN/ Appendix

Ean code	**Model No.	size(mm)	DOP number
3276005997165	** QD5010005001	1000×1900 silver	* DOP 207994/0017/2016
3276005997127	** QD5010005002	1000×1900 white	* DOP 207994/0017/2016
3276005997240	** QD5010005003	1000×1900 silver	* DOP 207994/0017/2016
3276005997202	** QD5010005004	1000×1900 white	* DOP 207994/0017/2016
3276005997325	** QD5011005001	1100×1900 silver	* DOP 207994/0017/2016
3276005997288	** QD5011005002	1100×1900 white	* DOP 207994/0017/2016
3276005997400	** QD5011005003	1100×1900 silver	* DOP 207994/0017/2016
3276005997363	** QD5011005004	1100×1900 white	* DOP 207994/0017/2016
3276005997486	** QD5012005001	1200×1900 silver	* DOP 207994/0017/2016
3276005997448	** QD5012005002	1200×1900 white	* DOP 207994/0017/2016
3276005997561	** QD5012005003	1200×1900 silver	* DOP 207994/0017/2016
3276005997523	** QD5012005004	1200×1900 white	* DOP 207994/0017/2016
3276000232582	** QD5013005001	1300×1900 silver	* DOP 207994/0017/2016
3276000232285	** QD5013005002	1300×1900 white	* DOP 207994/0017/2016
3276000232292	** QD5013005003	1300×1900 silver	* DOP 207994/0017/2016
3276005997646	** QD5014005001	1400×1900 silver	* DOP 207994/0017/2016
3276005997608	** QD5014005002	1400×1900 white	* DOP 207994/0017/2016
3276005997721	** QD5014005003	1400×1900 silver	* DOP 207994/0017/2016
3276005997684	** QD5014005004	1400×1900 white	* DOP 207994/0017/2016

FR/ Annexe	ES/ Apéndice	PT/ Anexo	IT/ Appendice
EL/ Παράρτημα	PL/ Załącznik	RU/ Приложение	UK/ Додаток
RO/ Anexa	EN/ Appendix		

Ean code	**Model No.	size(mm)	DOP number
3276000232599	** QD5015005001	1500×1900 silver	* DOP 207994/0017/2016
3276000232308	** QD5015005002	1500×1900 white	* DOP 207994/0017/2016
3276000232315	** QD5015005003	1500×1900 silver	* DOP 207994/0017/2016
3276000232605	** QD5016005001	1600×1900 silver	* DOP 207994/0017/2016
3276000232322	** QD5016005002	1600×1900 white	* DOP 207994/0017/2016
3276000232339	** QD5016005003	1600×1900 silver	* DOP 207994/0017/2016



QUAD

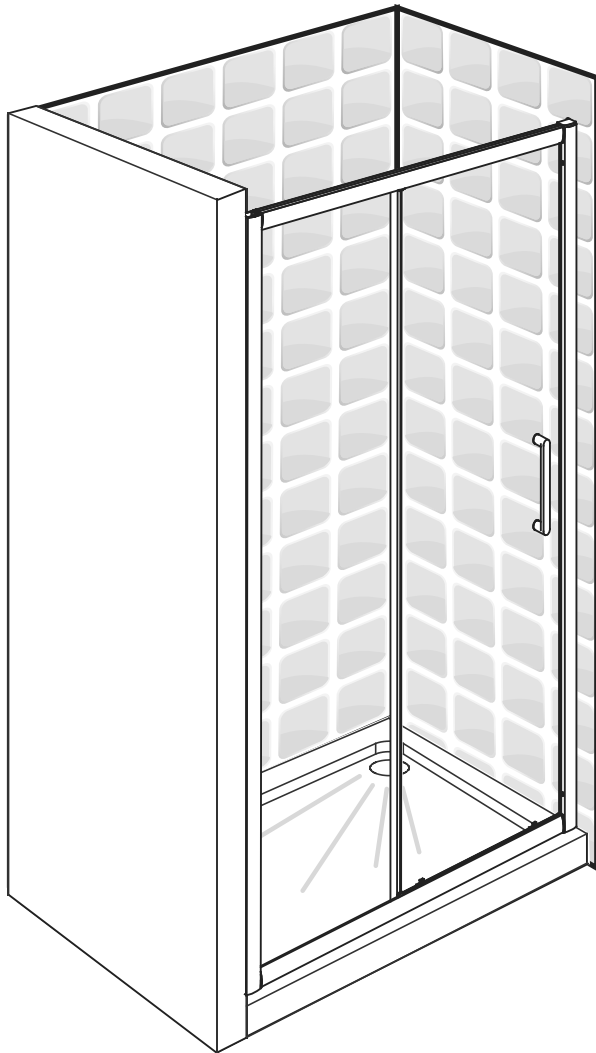

- FR Notice de Montage - Utilisation - Entretien
- ES Instrucciones de Montaje, Utilización y Mantenimiento
- PT Instruções de Montagem, Utilização e Manutenção
- IT Istruzioni per il Montaggio, l'Uso e la Manutenzione
- EL Εγχειρίδιο συναρμολόγησης, χρήσης και συντήρησης
- PL Instrukcja Montażu, Użytkowania i Konserwacji
- RU Руководство По Сборке и Эксплуатации
- UK Керівництво По Збірці і Експлуатації
- RO Manual asamblare, utilizare și întreținere
- EN Assembly - Use - Maintenance Manual

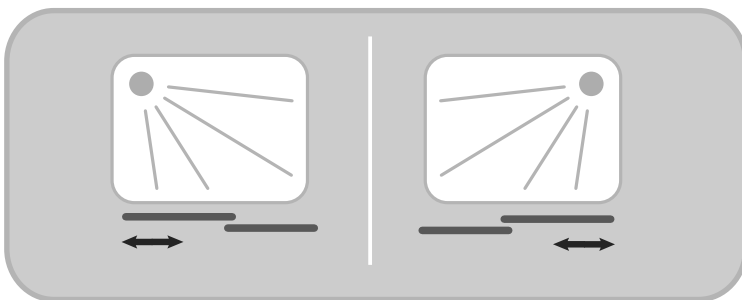

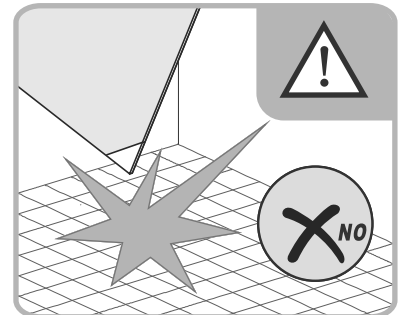
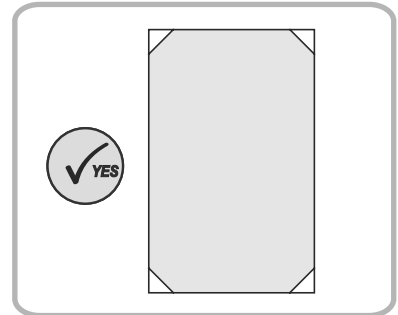
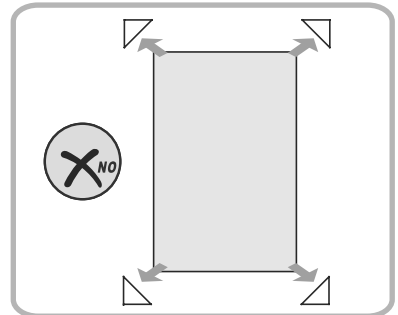
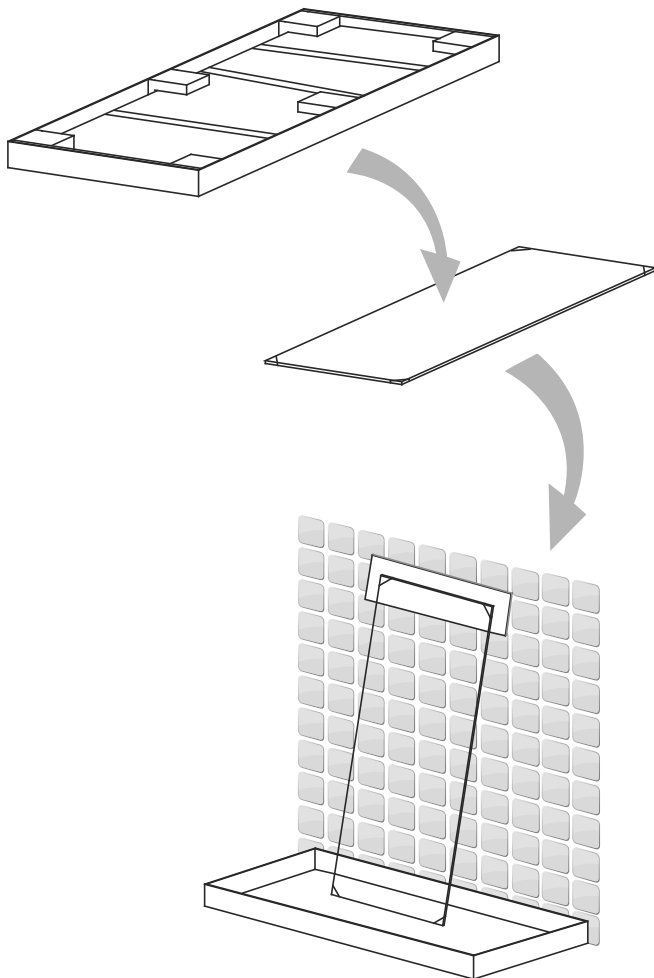
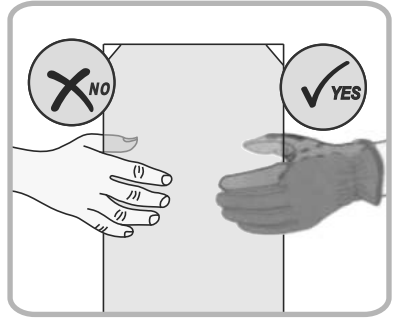
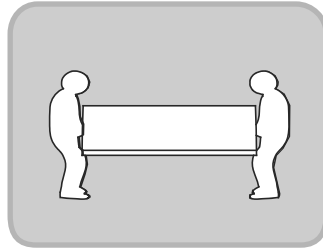
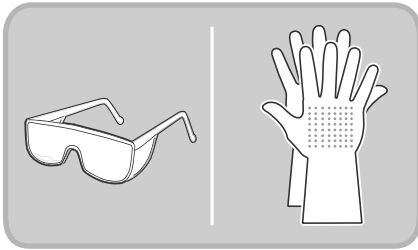
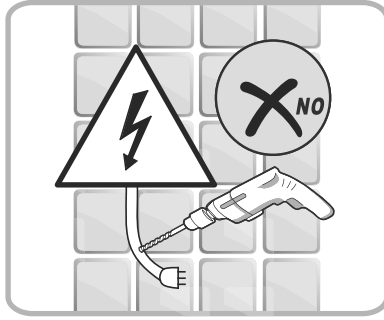
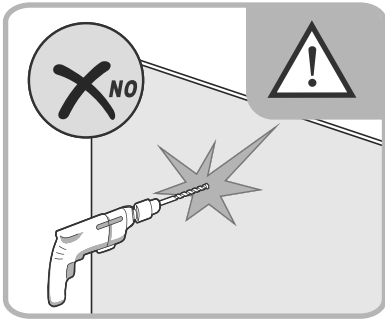

FR Vérifiez que les chevilles murales fournies sont appropriées à votre mur (celles fournies dans l'emballage sont conçues pour le béton). Sinon, utilisez des vis et des chevilles murales adaptées au type de matériau de votre mur. Pour obtenir des conseils concernant les vis et les chevilles appropriées à votre mur, demandez à un vendeur spécialisé.

ES Compruebe que todos los tacos suministrados puedan ser utilizados con su pared (los incluidos en la caja son para hormigón). En caso contrario, utilice tornillos y tacos de pared apropiados para el material de su pared. Para información acerca de las fijaciones y tornillos apropiados para su pared, consulte con un asistente de ventas especializado.

PT Certifique-se de que as buchas fornecidas são adequadas à sua parede (as fornecidas na embalagem são para betão). Caso contrário, use parafusos e buchas adequados ao tipo de material da sua parede. Para se aconselhar acerca dos parafusos e buchas adequados à sua parede, fale com um assistente de vendas especializado.

IT Verificare che i tasselli da parete forniti siano compatibili con la propria parete (quelli forniti con l'articolo sono per cemento). Altrimenti, utilizzare viti e tasselli adatti per la superficie della propria parete. Per ottenere consigli e suggerimenti sulle viti e i tasselli più adatti alla propria parete, consultare un rivenditore specializzato.

EL Βεβαιωθείτε ότι οι παρεχόμενες στερεώσεις τοίχου είναι κατάλληλες για τον τοίχο σας (οι παρεχόμενες στη συσκευή προορίζονται για μπετό). Αλλιώς χρησιμοποιήστε βίδες και στερεώσεις τοίχου κατάλληλες για τον τύπο υλικού του τοίχου σας. Για να λάβετε συμβουλές σχετικά με τις κατάλληλες βίδες και τα εξαρτήματα για τον τοίχο σας, ρωτήστε έναν ειδικό πωλητή.

PL Prosimy sprawdzić, czy dostarczone kołki do ścian nadają się do użycia w posiadanej ścianie (kołki dostarczone w zestawie są przeznaczone do betonu). Jeśli tak nie jest, należy użyć śrub i kołków odpowiednich do materiału, z którego wykonana jest ściana. Aby uzyskać poradę w sprawie śrub i elementów montażowych odpowiednich do danego typu ściany, należy zwrócić się z pytaniem do wyspecjalizowanego sprzedawcy.

RU Убедитесь, что прилагаемые дюбеля подходят для ваших стен (входящие в комплект дюбеля предназначены для бетона). В противном случае используйте шурупы и дюбеля, соответствующие материалу стены. Для получения рекомендаций по выбору шурупов и крепежных деталей, подходящих для вашей стены, обратитесь к специалисту-консультанту.

UK Перевірте, що анкери підходять для вашої стіни (ті, що постачаються в упаковці – для бетону). В іншому випадку використовуйте гвинти й стінові анкери, що відповідають матеріалу вашої стіни. Для отримання консультації щодо гвинтів й фітингів для вашої стіни зверніться до відповідного продавця-консультанта.

RO Verificați ca toate ancorele de perete furnizate să fie adecvate pentru peretele dumneavoastră (cele furnizate în pachet sunt pentru beton). În caz contrar, folosiți șuruburi și ancore de perete adecvate pentru tipul de material din care este peretele dumneavoastră. Pentru a obține recomandări privind șuruburile și armăturile adecvate pentru peretele dumneavoastră, întrebați un vânzător specializat.

EN Check that wall anchors provided are suitable for your wall (those provided in the package are for concrete). Otherwise, use screws and wall anchors suited to the type of material of your wall. To obtain advice on the screws and fittings suited to your wall, ask a specialized sales assistant.

2



3M

Assemble with this side, with easy clean treatment, on the inside.

İze karşı işleme tabi tutulmuş bu yüz iç tarafa doğru konulmalıdır

Cette face, avec un traitement facilement nettoyable, doit être positionnée vers l'intérieur

Esta cara está tratada para facilitar su limpieza y se debe colocar hacia el interior

Esta face com tratamento para facilitar a limpeza, deve ficar voltada para o interior

Questo lato, deve essere posizionato con il trattamento easy clean all'interno.

Эта сторона, обработанная средством против образования накипи, должна быть обращена вовнутрь.

Сторона, оброблена засобом проти накипу, повинна бути звернена всередину.

Această față, tratată pentru curățare ușoară, trebuie poziționată spre interior

Strona z powłoką zapewniającą łatwe czyszczenie powinna być skierowana do wewnątrz.

Αυτή η όψη, με επεξεργασία για εύκολο καθαρισμό, πρέπει να τοποθετηθεί προς το εσωτερικό.

V.7 2014



Attention danger / Atención: Peligro / Atencão perigo / Attenzione pericolo / Προσοχή κίνδυνος /
Uwaga niebezpieczeństwo / Внимание! Опасно! / Увага! Небезпечно! / Atentie, pericol / Caution danger



Correct / Correcto / Corretto / Σωστό / Dobrze / Правильный /
Правильно / Corect / Correct



Incorrect / Incorrecto / Errato / Λάθος / Źle / Неправильный /
Неправильно / Incorect / Incorrect

Notes / Observaciones / Notas / Note / Σημειώσεις / Notatki / Примечания / Примітки / Note / Notes

FR Préparation

ES Preparación

PT Preparação

IT Preparazione

EL Προετοιμασία

PL Przygotowanie

RU Подготовка

UK Підготування

RO Pregătire

EN Preparation

A

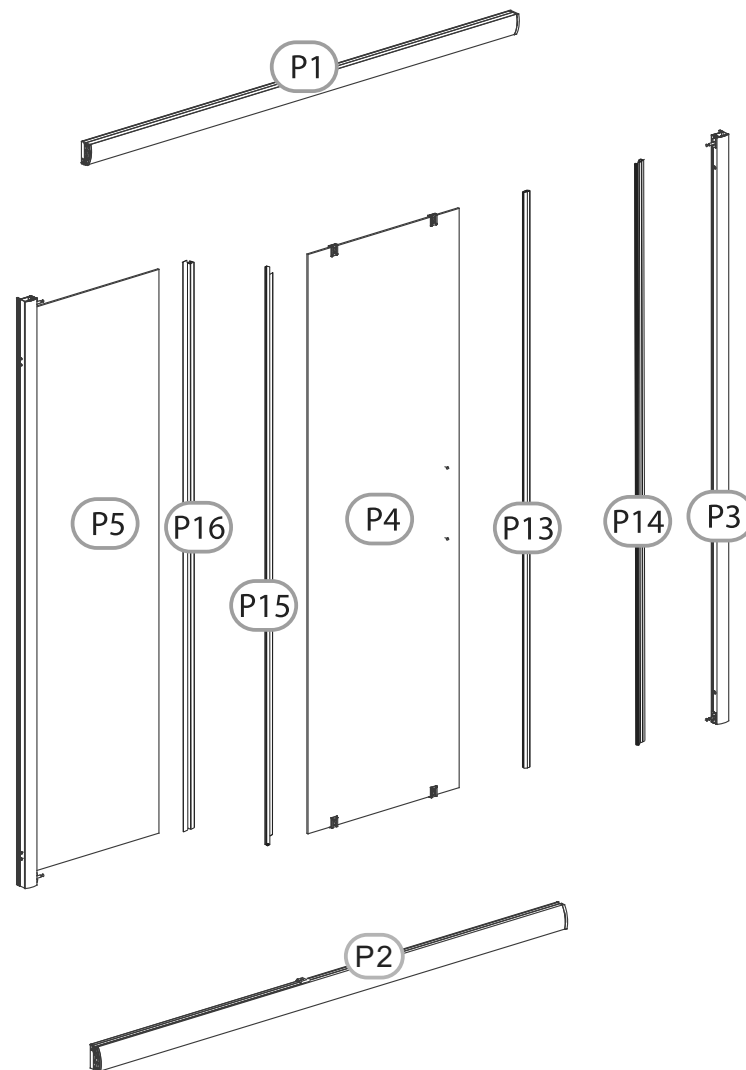
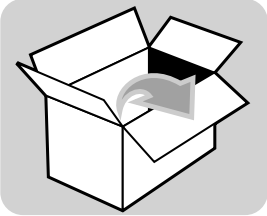

A

FR Préparation

ES Preparación

PT Preparação

IT Preparazione

EL Προετοιμασία

PL Przygotowanie

RU Подготовка

UK Підготування

RO Pregătire

EN Preparation

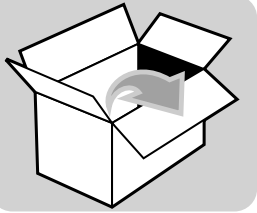

H1



x4

H2

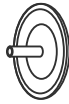

x4

H3



x6

H4



ST4x30mm

x6

H5



x10

H8



x1

H9

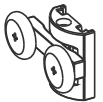

x2

H10



x2

H11

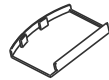

x1

H12

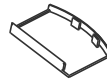

x1

H13



x2

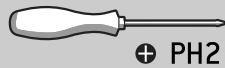
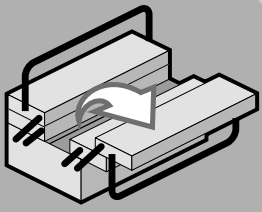

⊕ PH2



∅ 6mm

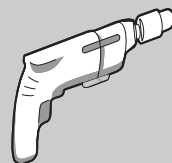
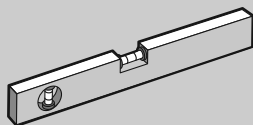
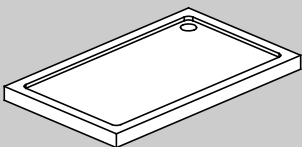
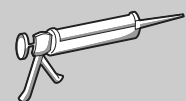
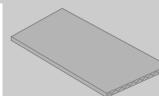
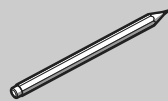
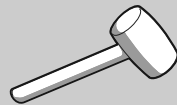

FR Montage

ES Montaje

PT Montagem

IT Montaggio

EL Συναρμολόγηση

PL Montaż

RU Сборка

UK Збірка

RO Montaj

EN Assembly

B

1

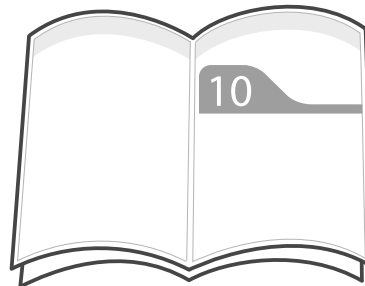
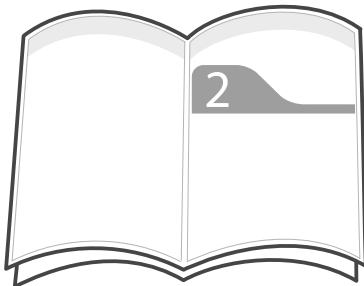
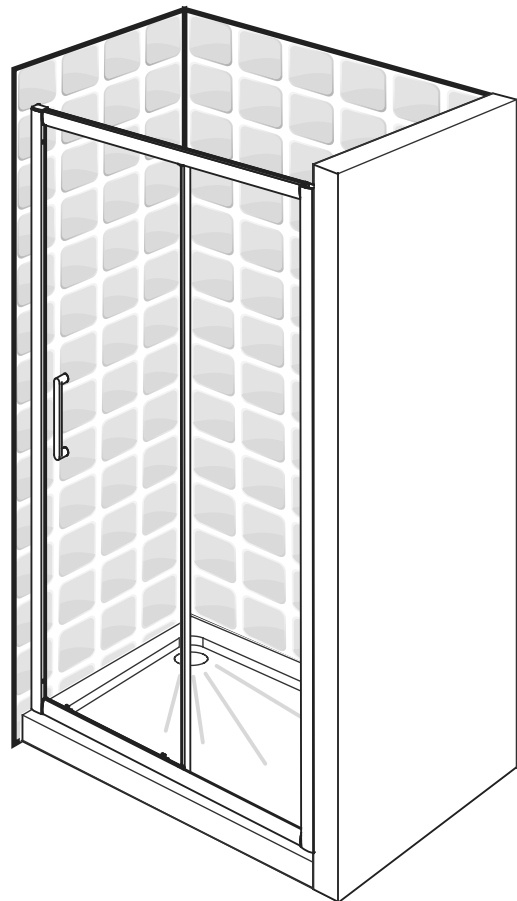
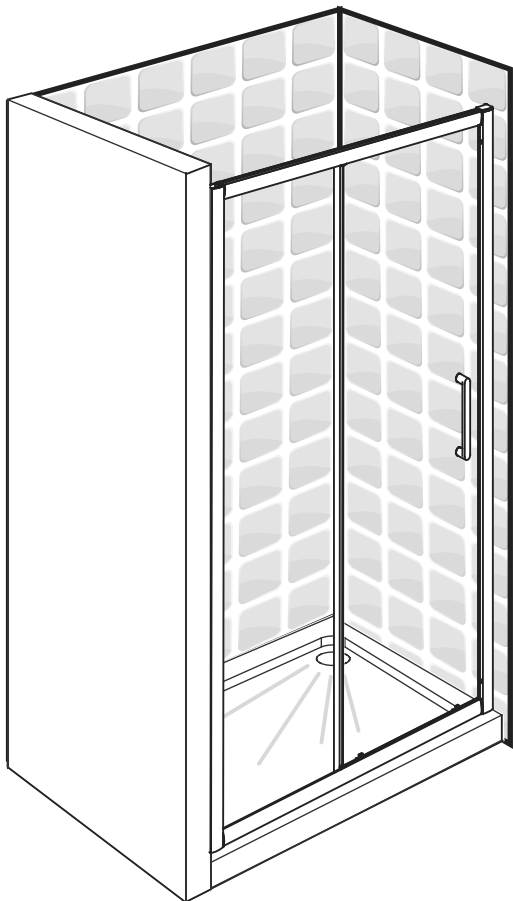

B

FR Montage

ES Montaje

PT Montagem

IT Montaggio

EL Συναρμολόγηση

PL Montaż

RU Сборка

UK Збірка

RO Montaj

EN Assembly

2

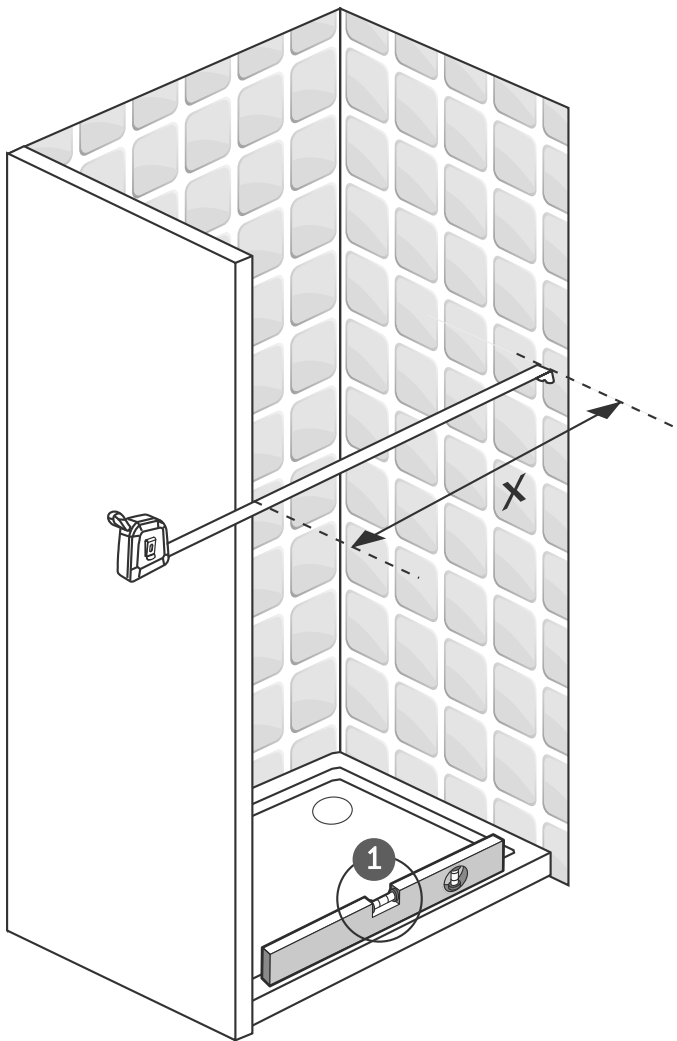

QUAD	X(mm)
1000x1900 mm	975-1005
1100x1900 mm	1075-1105
1200x1900 mm	1175-1205
1300x1900 mm	1275-1305
1400x1900 mm	1375-1405
1500x1900 mm	1475-1505
1600x1900 mm	1575-1605

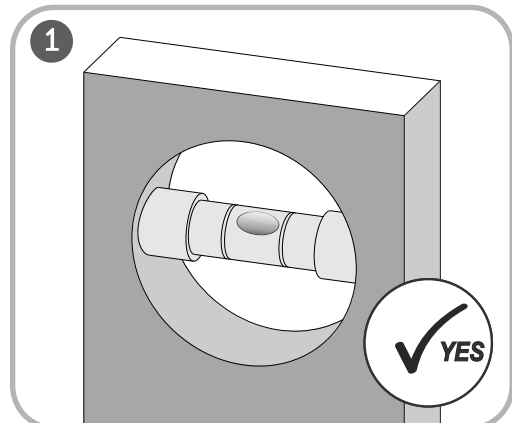
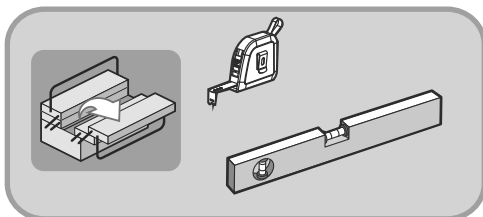
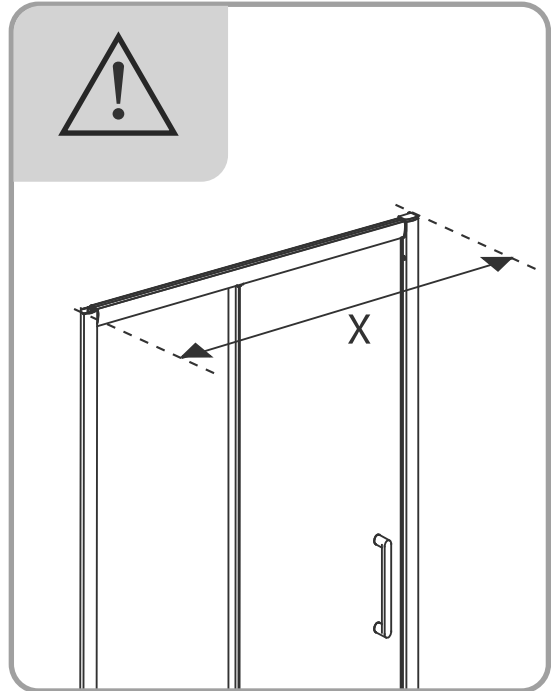

FR Montage

ES Montaje

PT Montagem

IT Montaggio

EL Συναρμολόγηση

PL Montaż

RU Сборка

UK Збірка

RO Montaj

EN Assembly

B

3

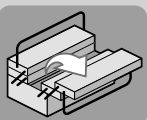
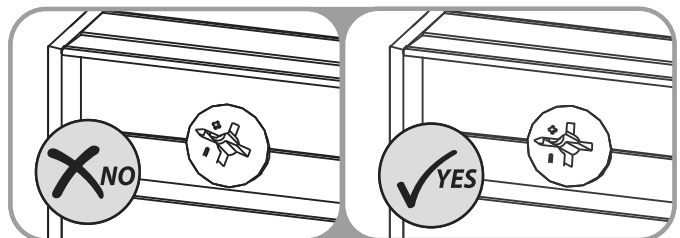
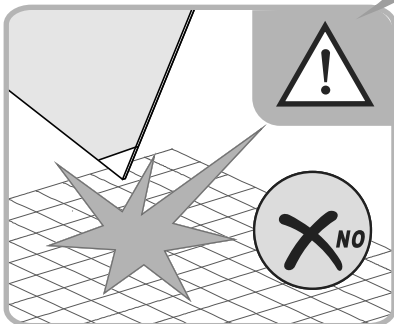
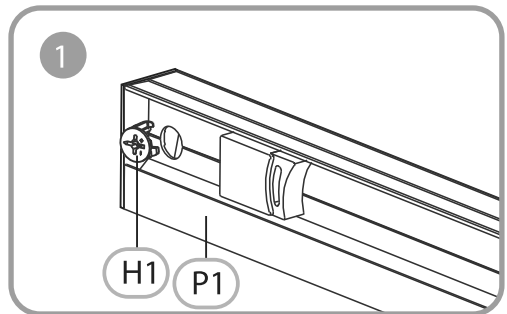
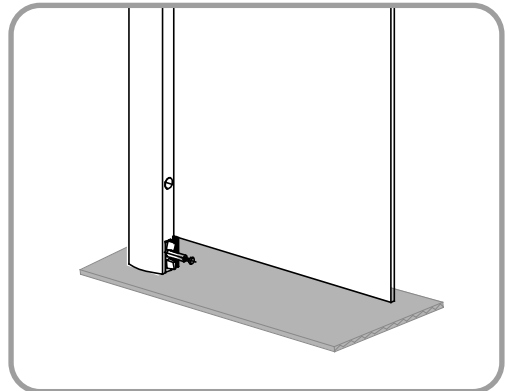
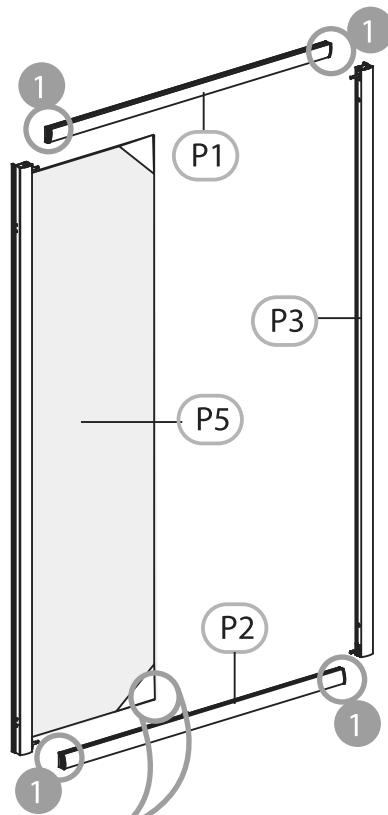
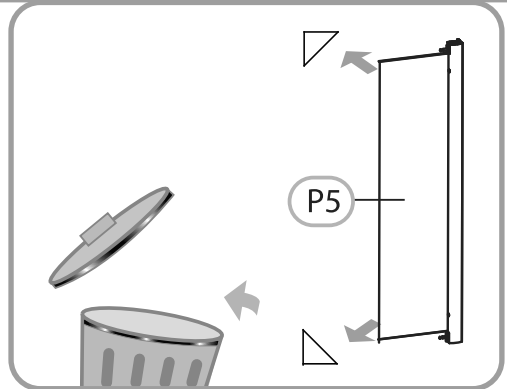
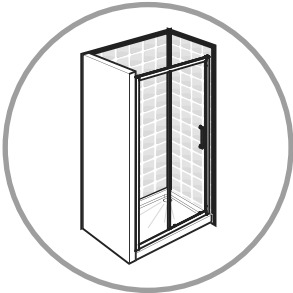

H1



x4

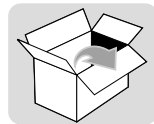

B

FR Montage

ES Montaje

PT Montagem

IT Montaggio

EL Συναρμολόγηση

PL Montaż

RU Сборка

UK Збірка

RO Montaj

EN Assembly

4

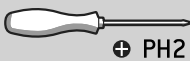
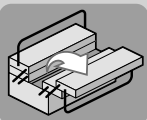
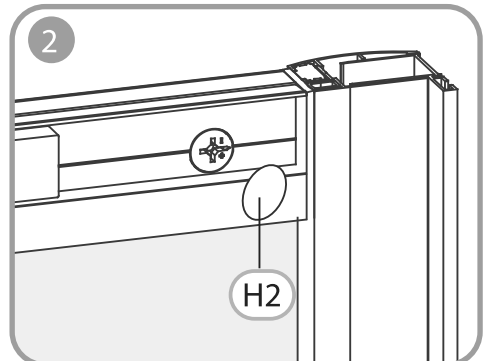
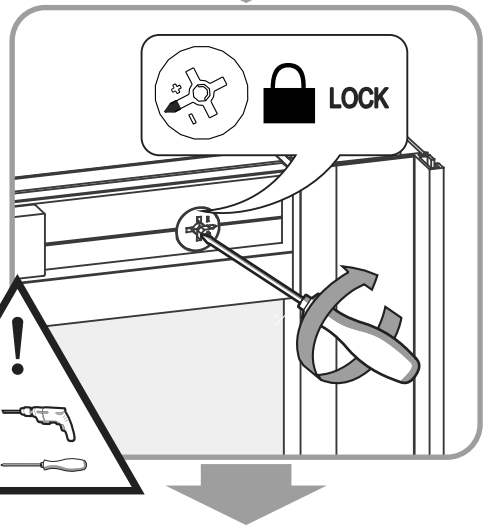
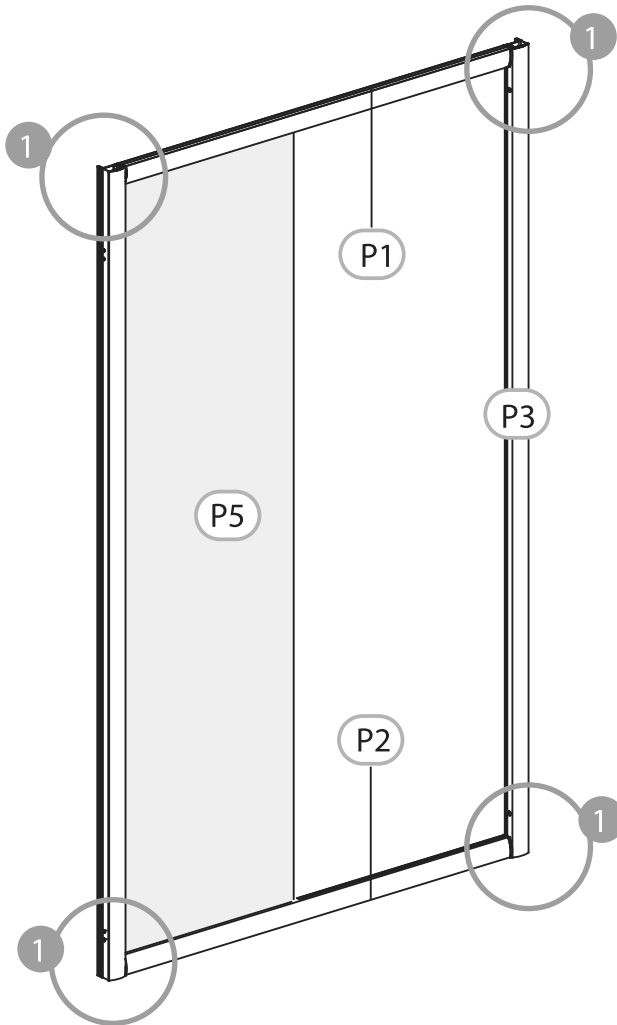
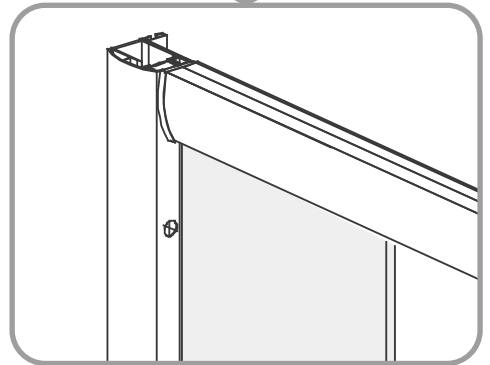
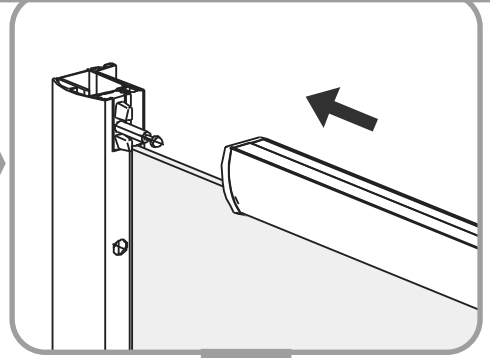
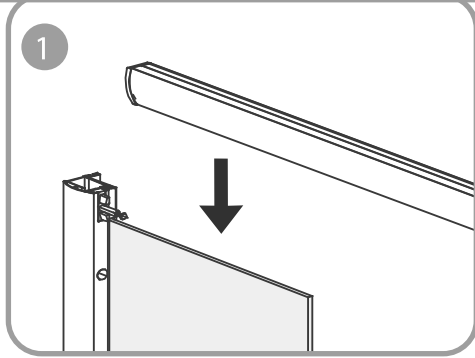
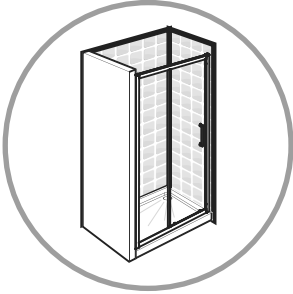

H2 x4

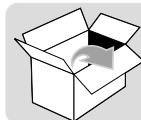

FR Montage

ES Montaje

PT Montagem

IT Montaggio

EL Συναρμολόγηση

PL Montaż

RU Сборка

UK Збірка

RO Montaj

EN Assembly

B

5

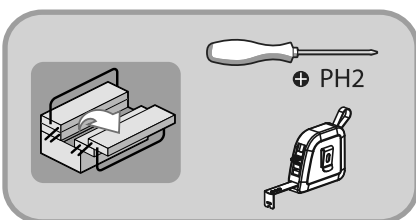
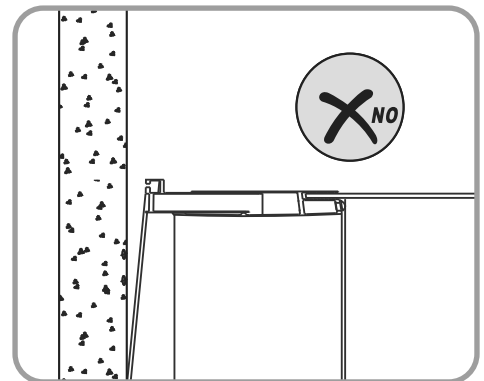
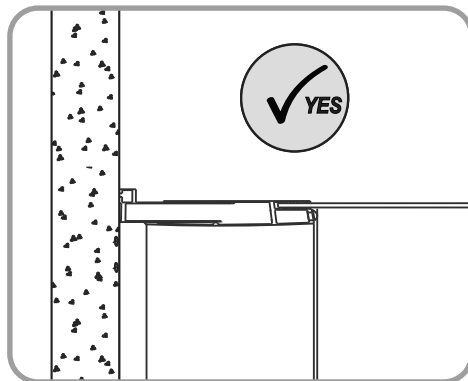
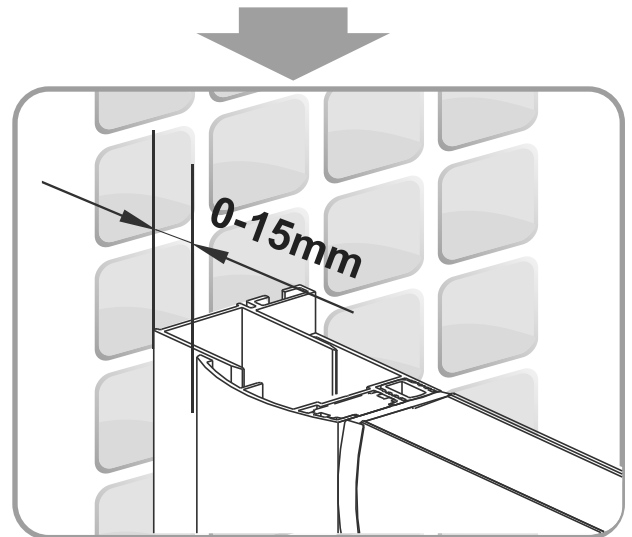
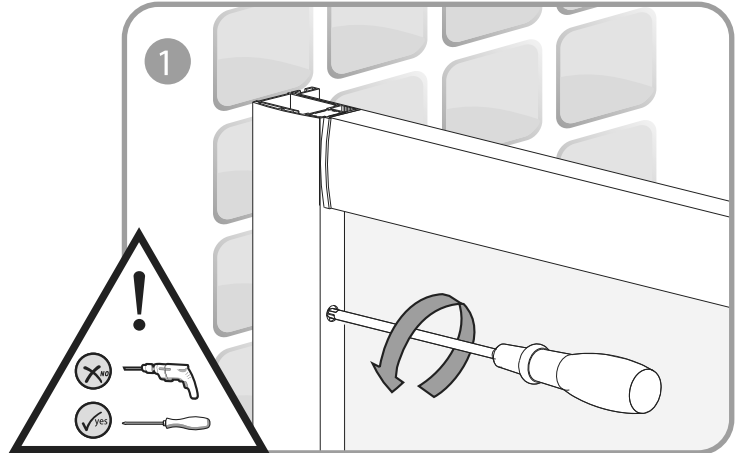
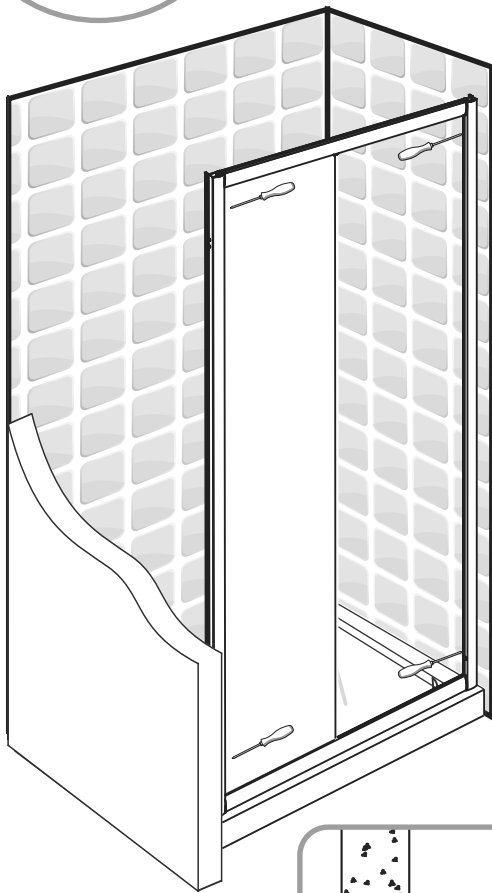
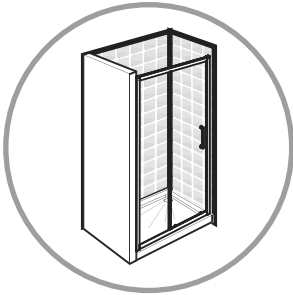

B

FR Montage

ES Montaje

PT Montagem

IT Montaggio

EL Συναρμολόγηση

PL Montaż

RU Сборка

UK Збірка

RO Montaj

EN Assembly

6

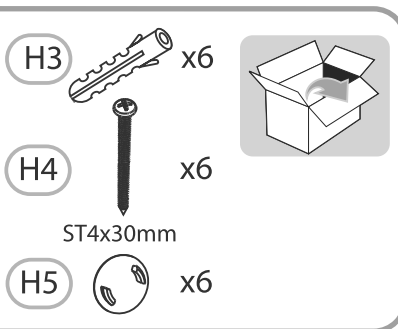
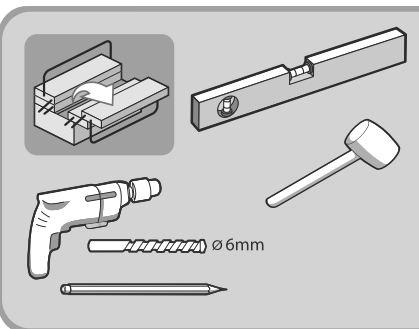
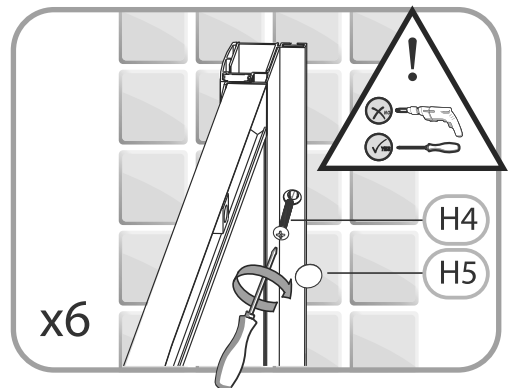
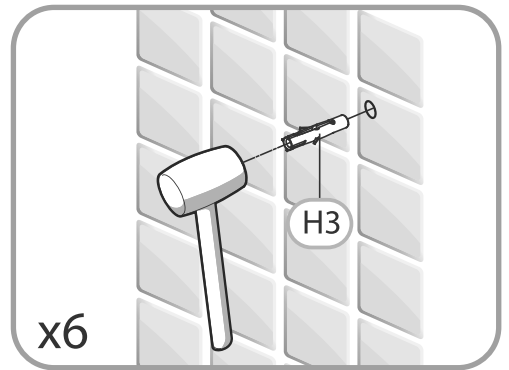
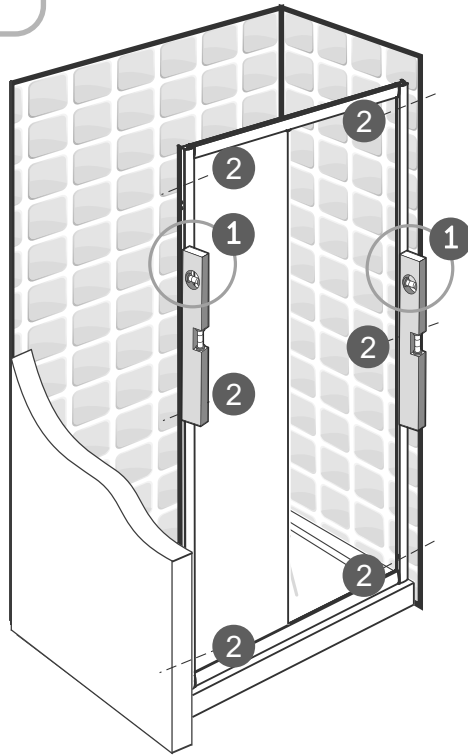
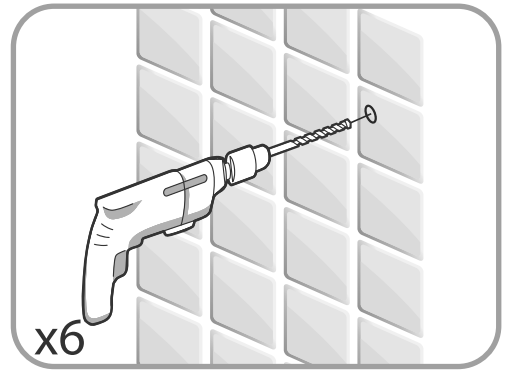
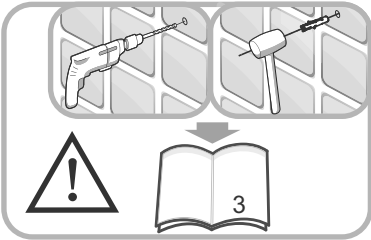
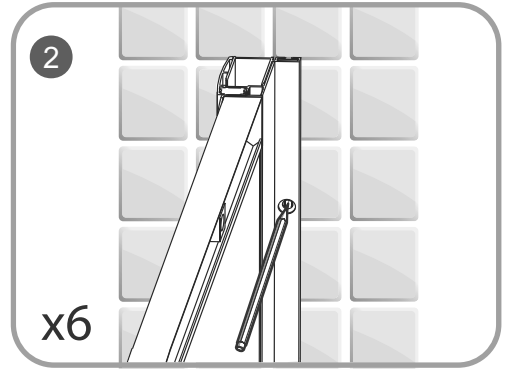
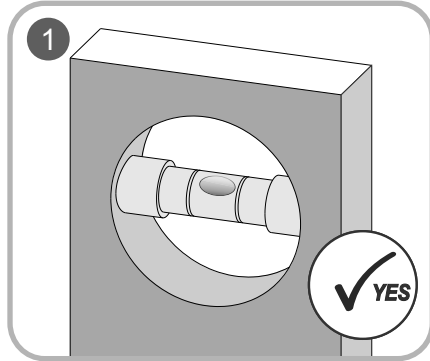
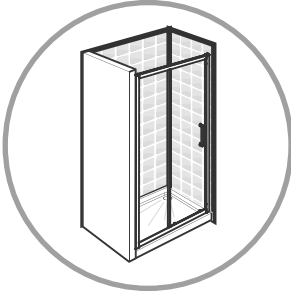

FR Montage

ES Montaje

PT Montagem

IT Montaggio

EL Συναρμολόγηση

PL Montaż

RU Сборка

UK Збірка

RO Montaj

EN Assembly

B

7

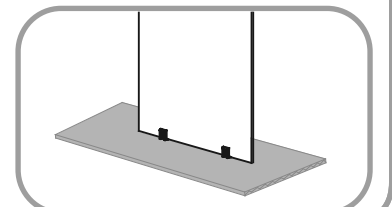
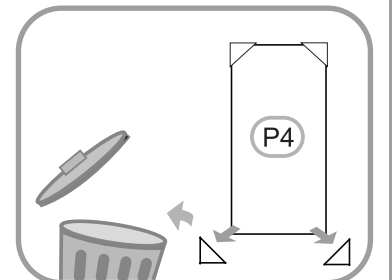
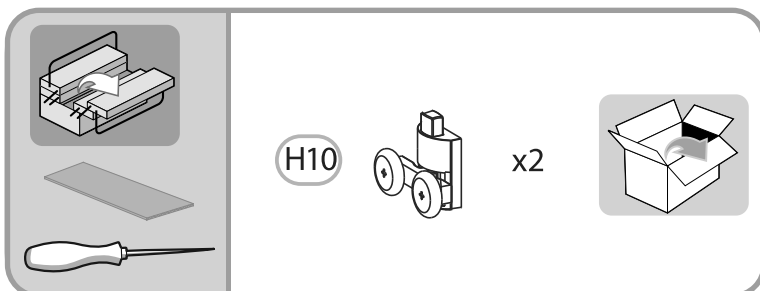
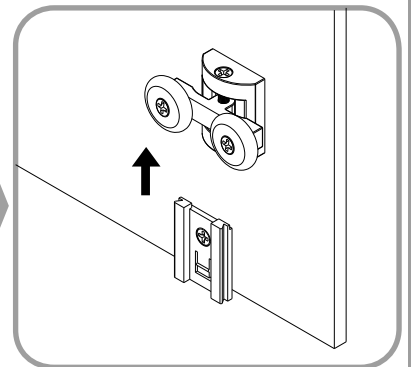
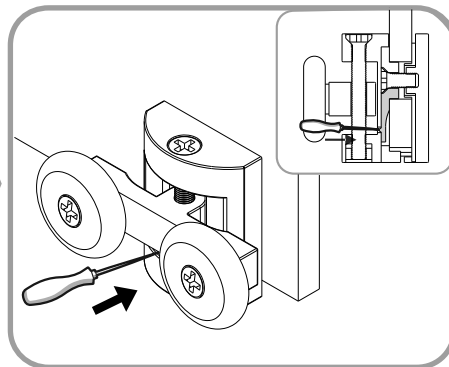
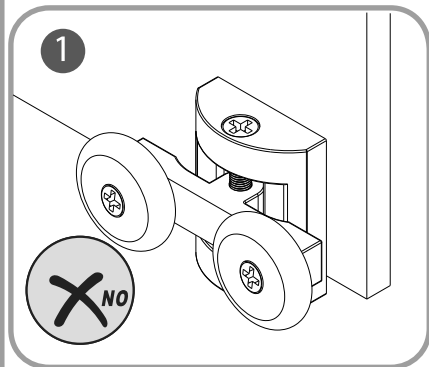
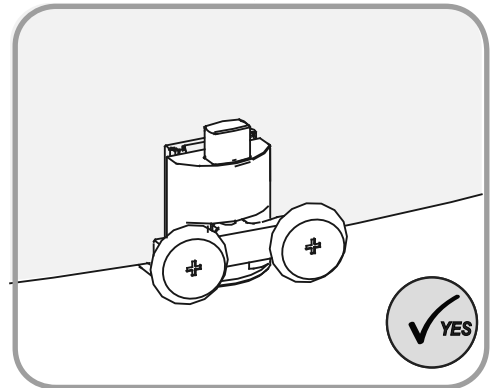
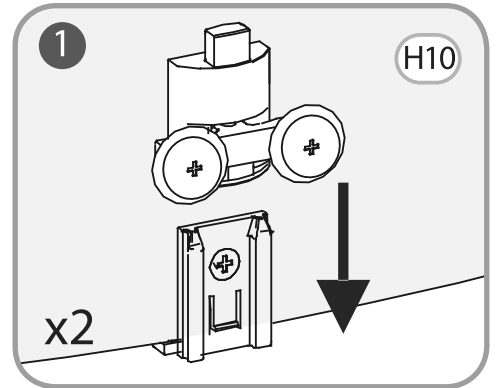
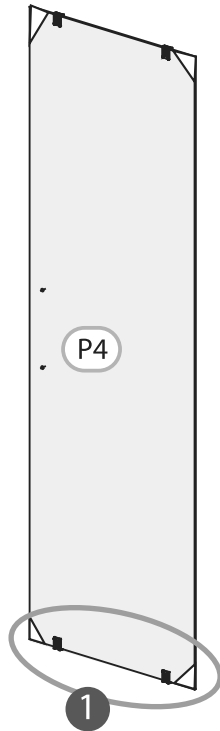
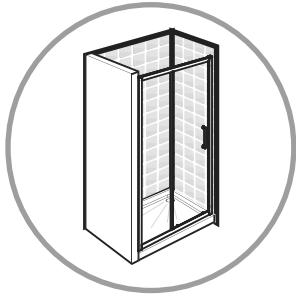

B

FR Montage

ES Montaje

PT Montagem

IT Montaggio

EL Συναρμολόγηση

PL Montaż

RU Сборка

UK Збірка

RO Montaj

EN Assembly

8

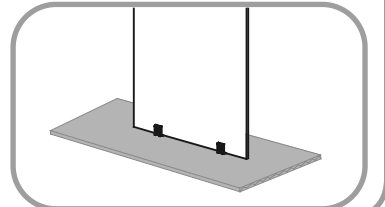
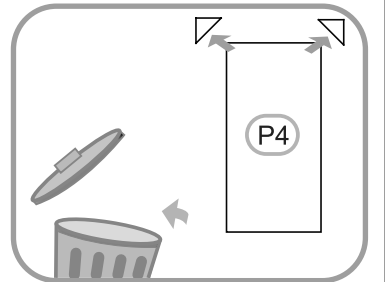
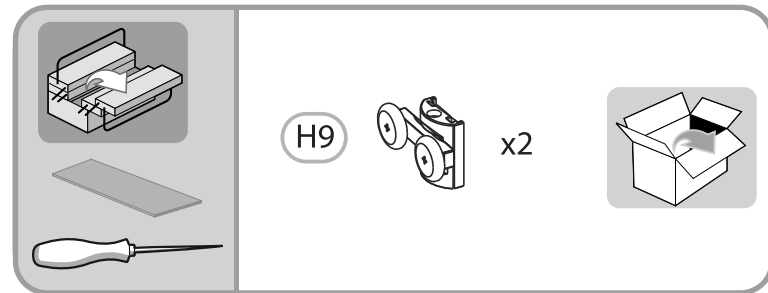
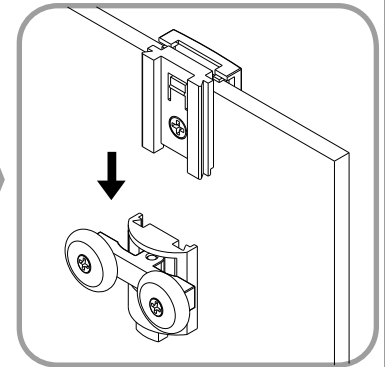
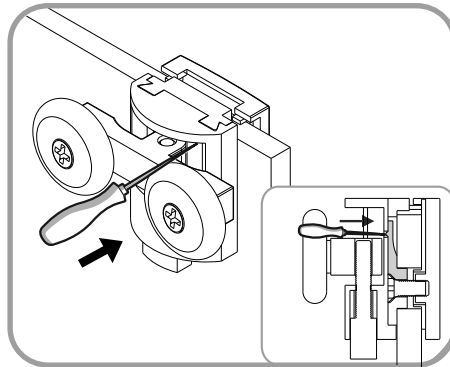
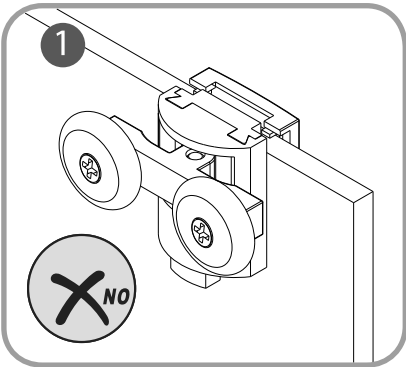
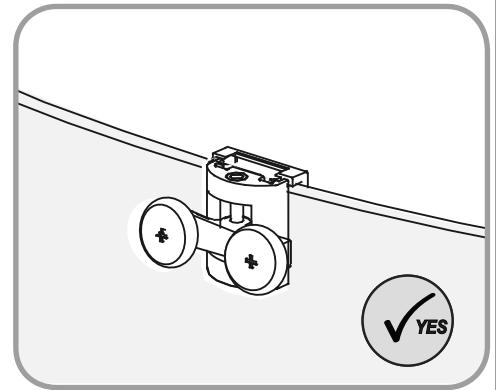
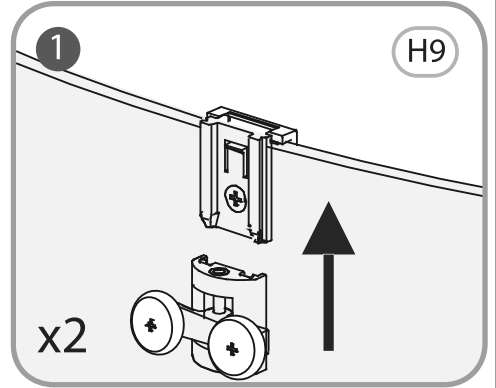
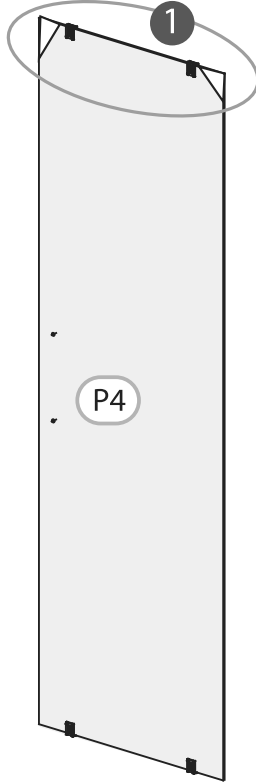
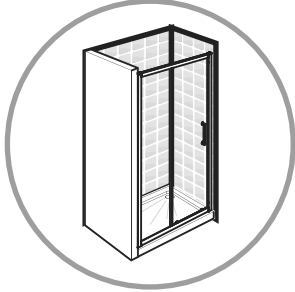

FR Montage

ES Montaje

PT Montagem

IT Montaggio

EL Συναρμολόγηση

PL Montaż

RU Сборка

UK Збірка

RO Montaj

EN Assembly

B

9

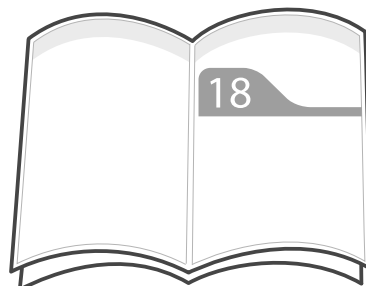
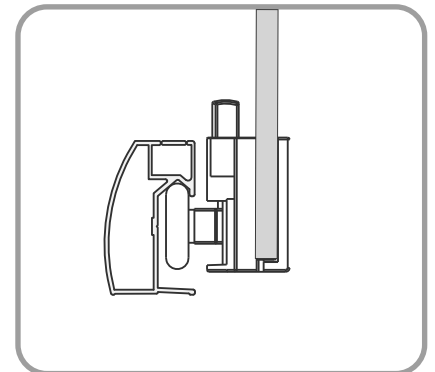
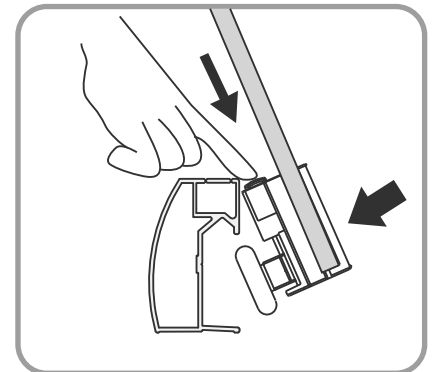
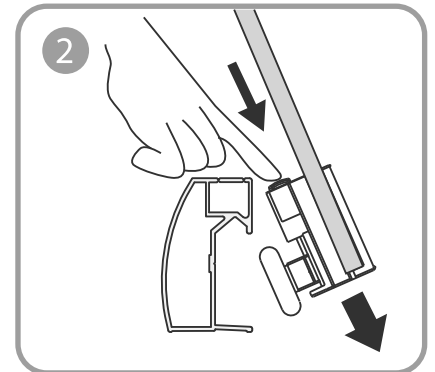
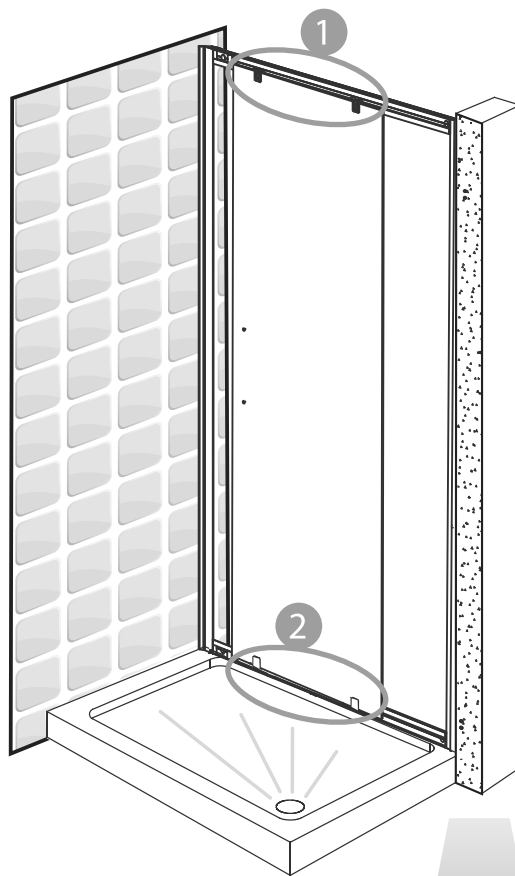
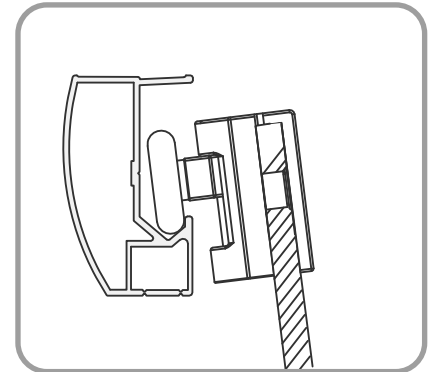
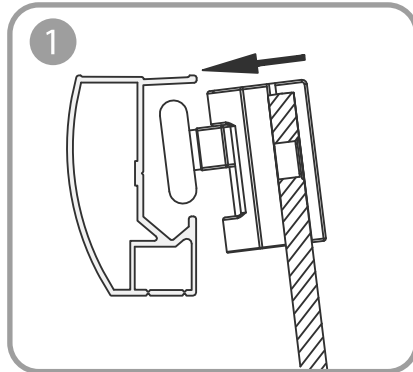
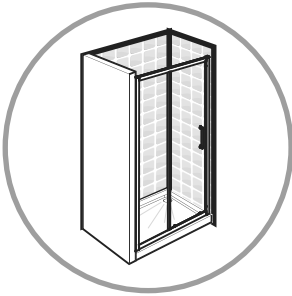

B

FR Montage

ES Montaje

PT Montagem

IT Montaggio

EL Συναρμολόγηση

PL Montaż

RU Сборка

UK Збірка

RO Montaj

EN Assembly

10

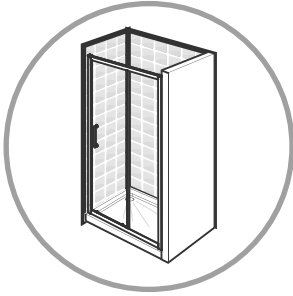

QUAD	X(mm)
1000x1900 mm	975-1005
1100x1900 mm	1075-1105
1200x1900 mm	1175-1205
1300x1900 mm	1275-1305
1400x1900 mm	1375-1405
1500x1900 mm	1475-1505
1600x1900 mm	1575-1605

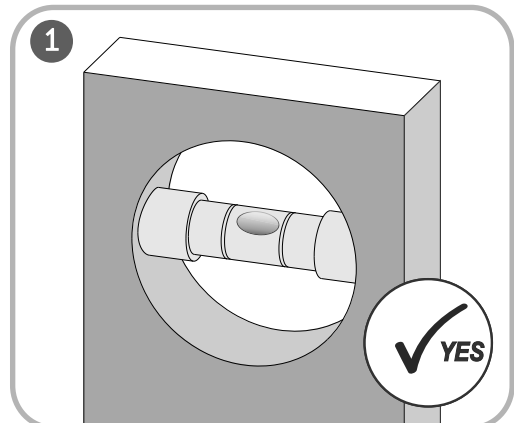
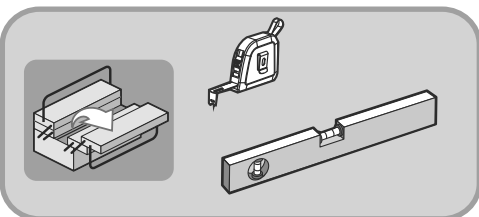
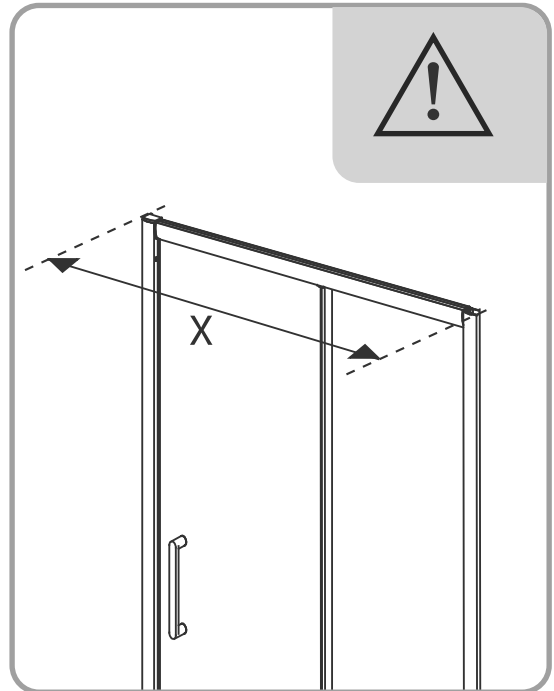
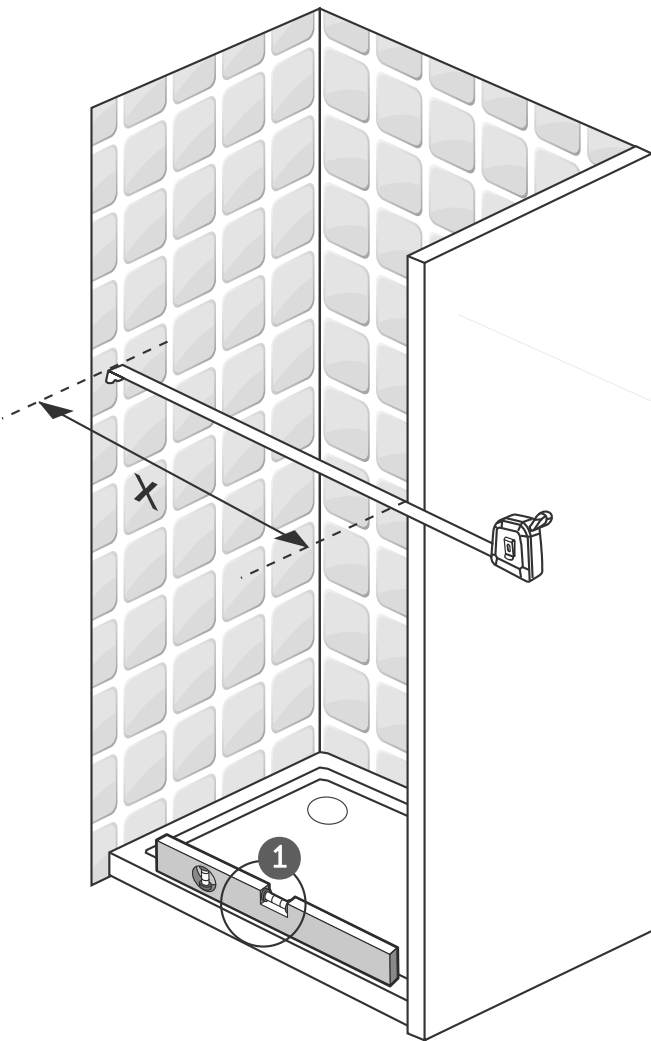

FR Montage

ES Montaje

PT Montagem

IT Montaggio

EL Συναρμολόγηση

PL Montaż

RU Сборка

UK Збірка

RO Montaj

EN Assembly

B

11

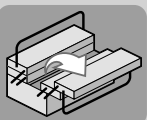
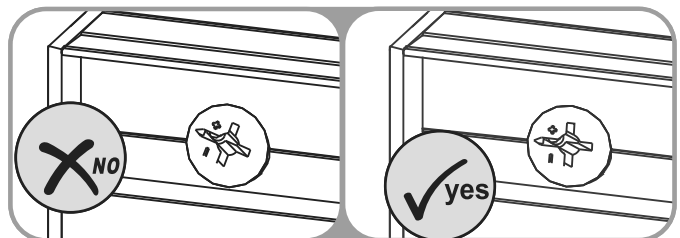
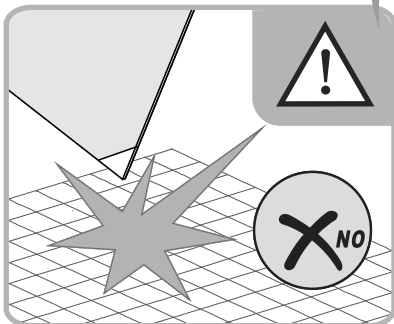
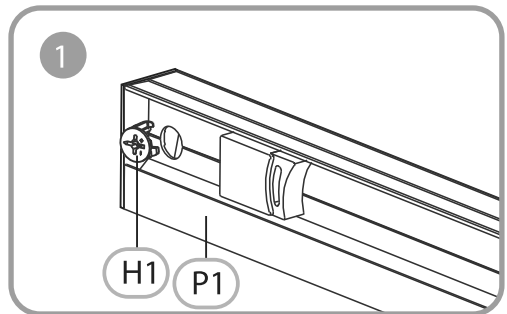
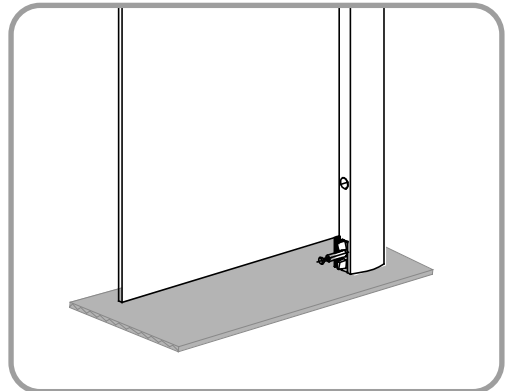
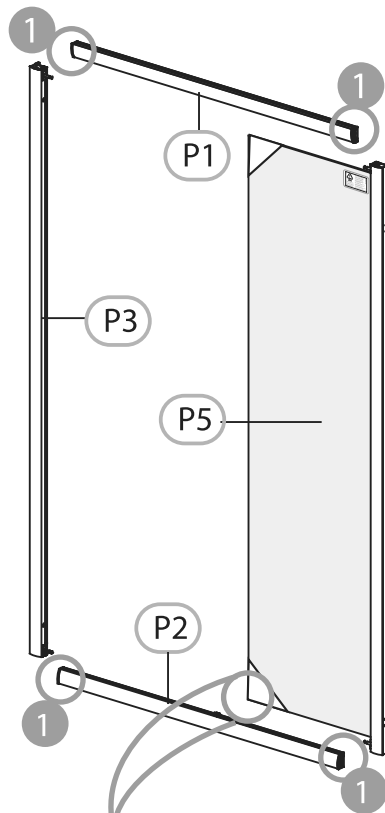
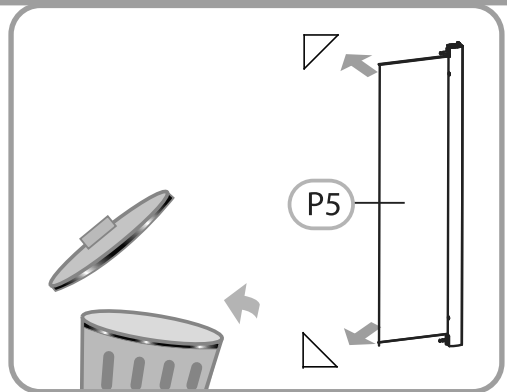
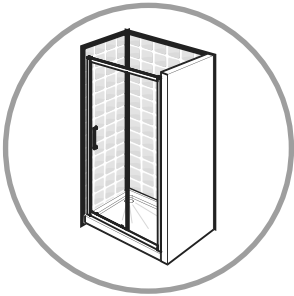

H1



x4

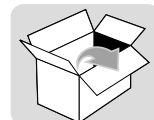

B

FR Montage

ES Montaje

PT Montagem

IT Montaggio

EL Συναρμολόγηση

PL Montaż

RU Сборка

UK Збірка

RO Montaj

EN Assembly

12

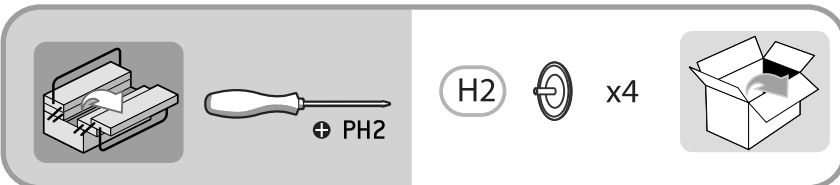
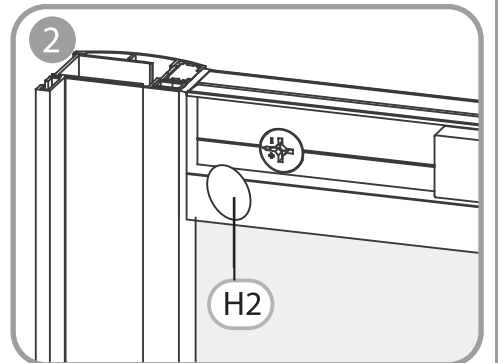
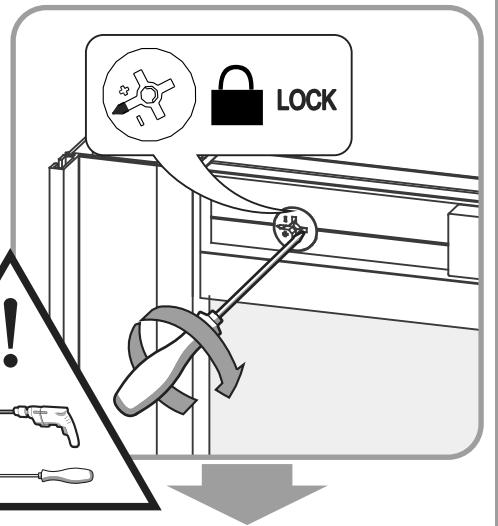
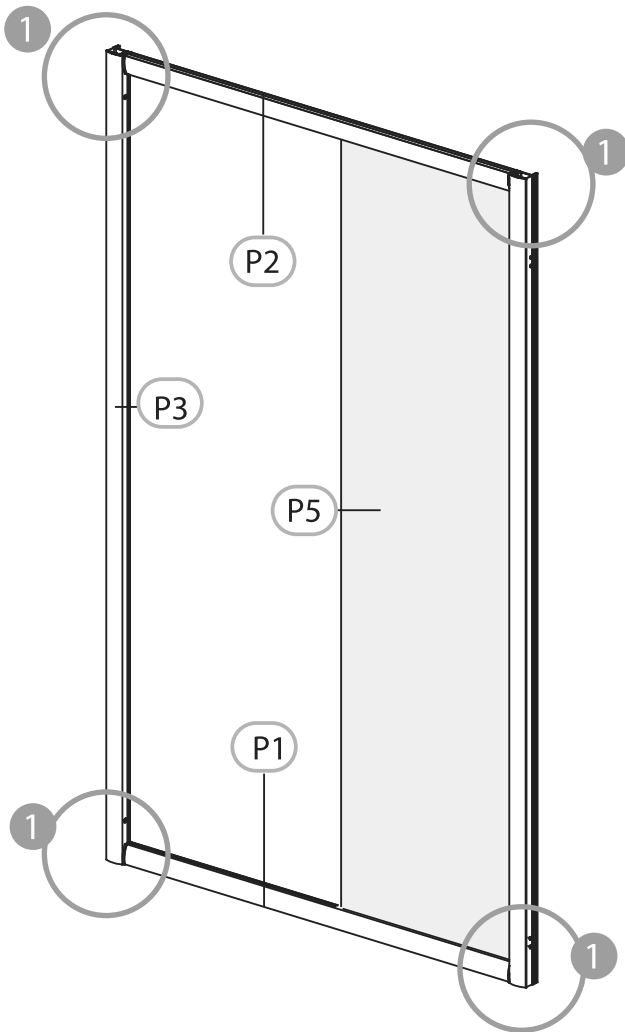
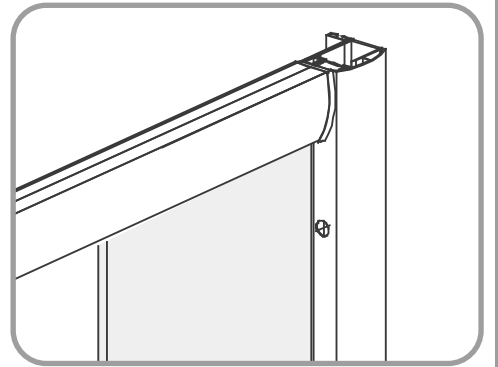
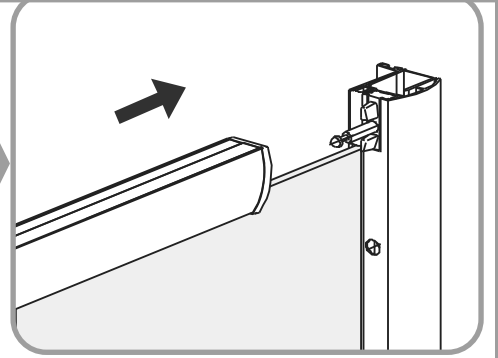
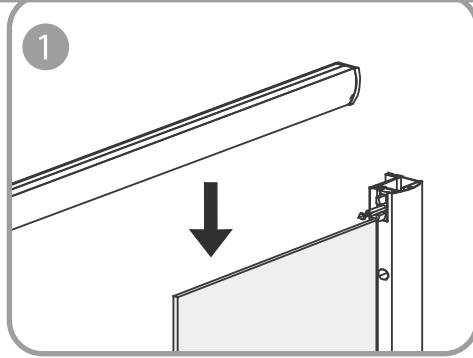
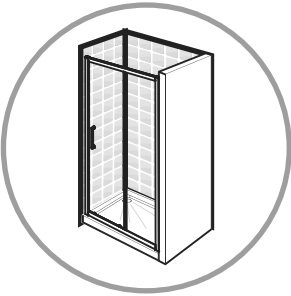

FR Montage

ES Montaje

PT Montagem

IT Montaggio

EL Συναρμολόγηση

PL Montaż

RU Сборка

UK Збірка

RO Montaj

EN Assembly

B

13

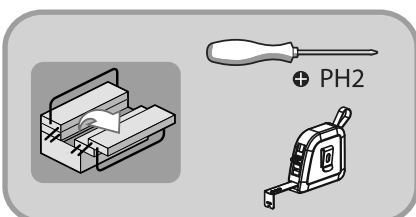
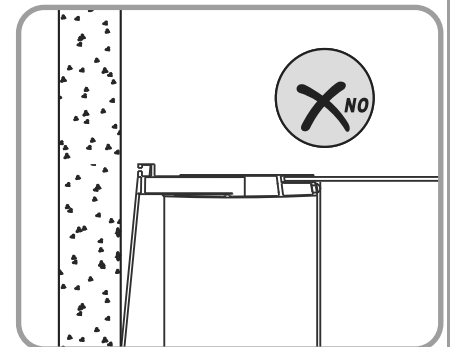
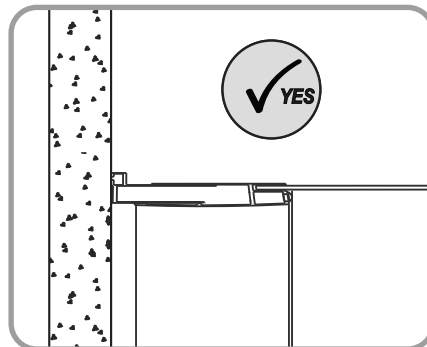
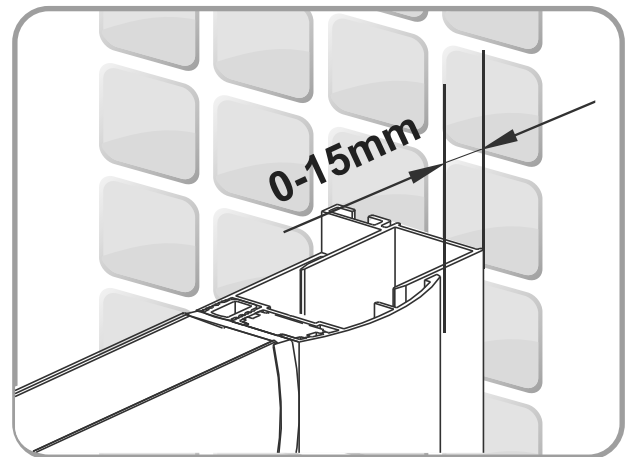
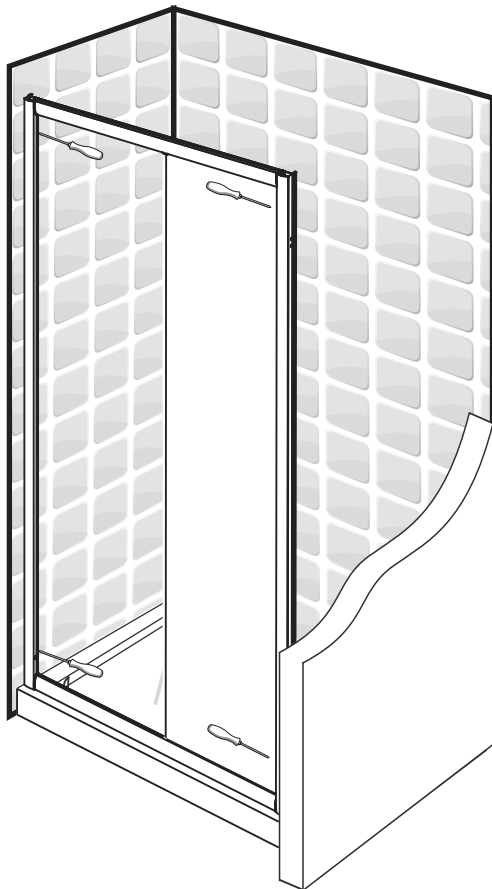
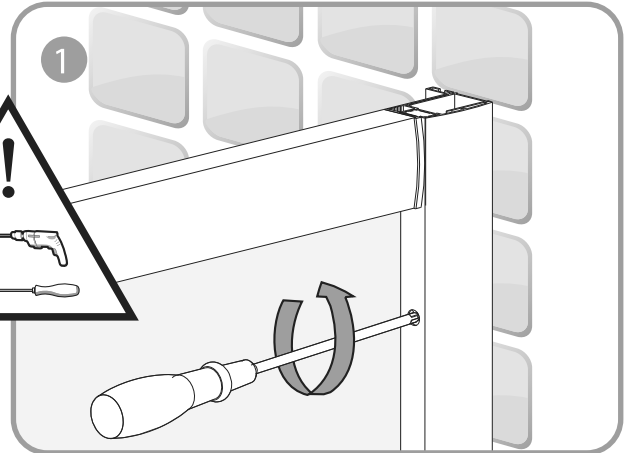
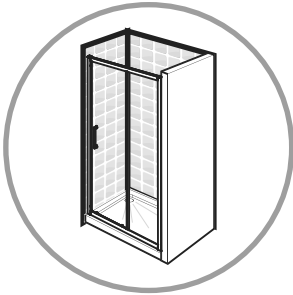

B

FR Montage

ES Montaje

PT Montagem

IT Montaggio

EL Συναρμολόγηση

PL Montaż

RU Сборка

UK Збірка

RO Montaj

EN Assembly

14

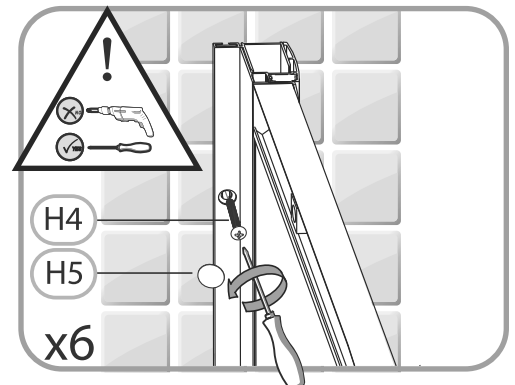
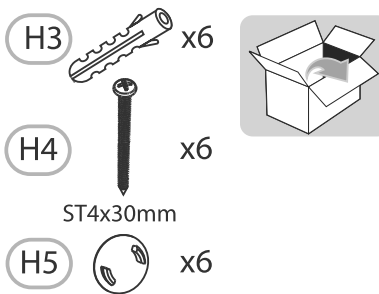
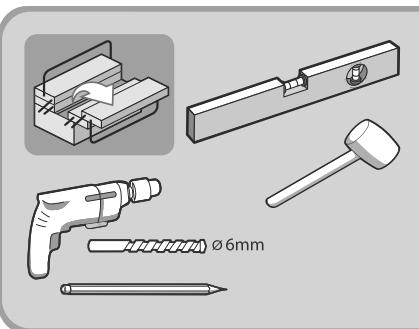
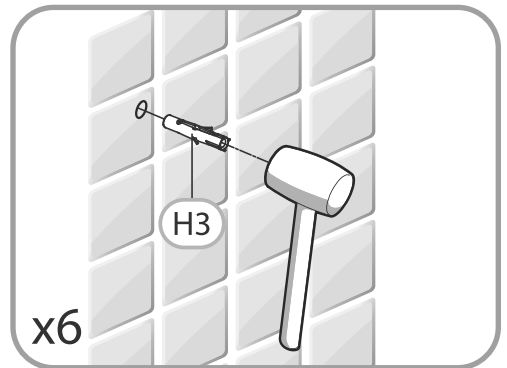
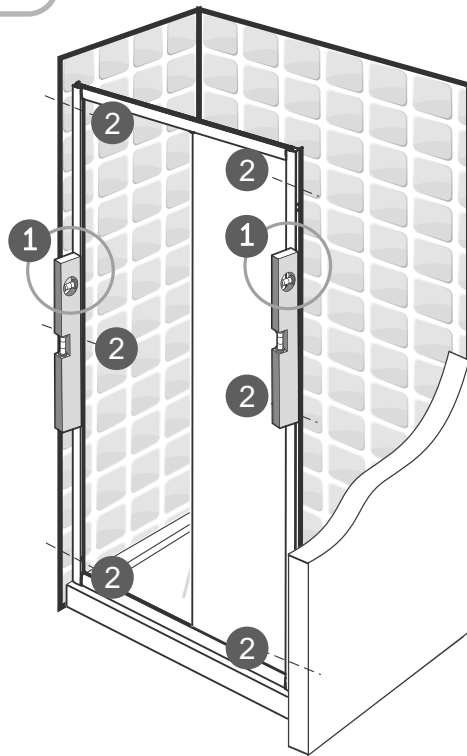
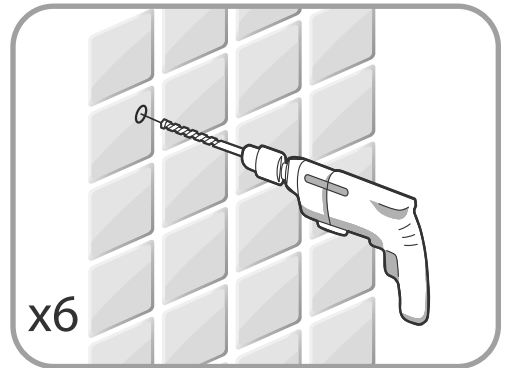
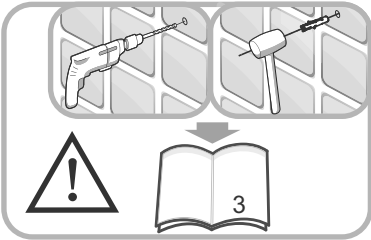
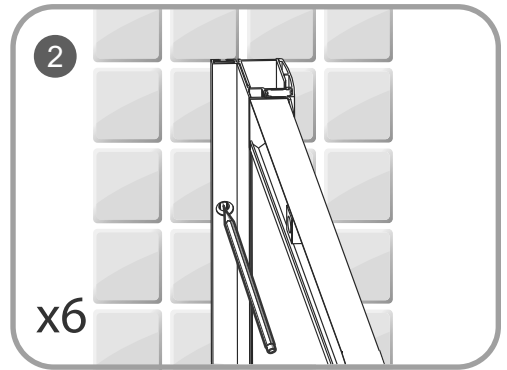
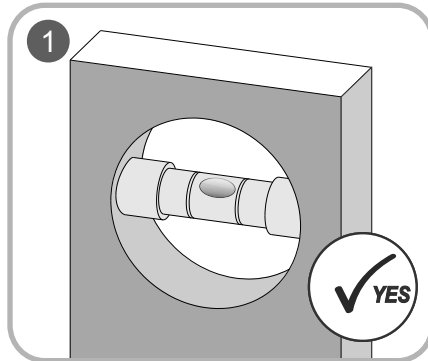
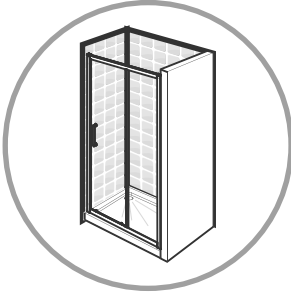

FR Montage

ES Montaje

PT Montagem

IT Montaggio

EL Συναρμολόγηση

PL Montaż

RU Сборка

UK Збірка

RO Montaj

EN Assembly

B

15

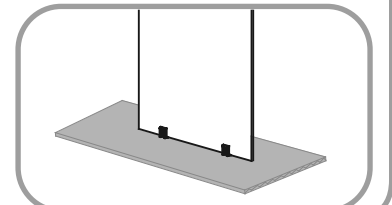
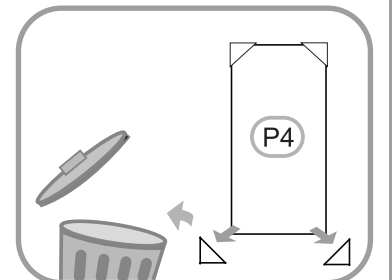
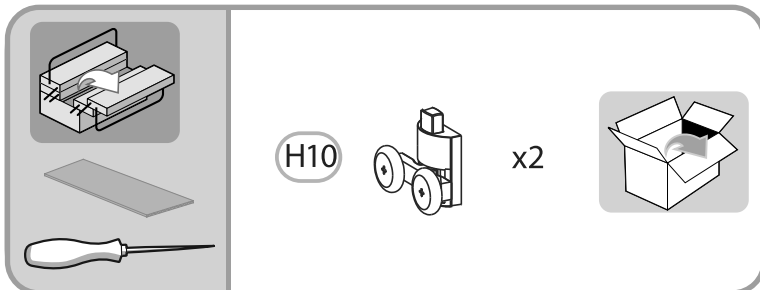
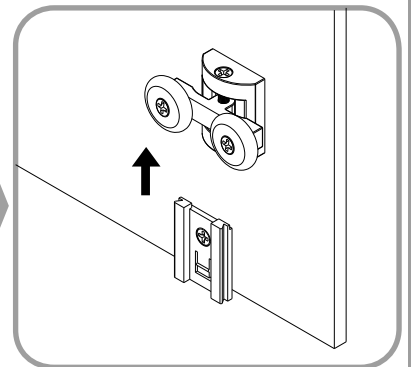
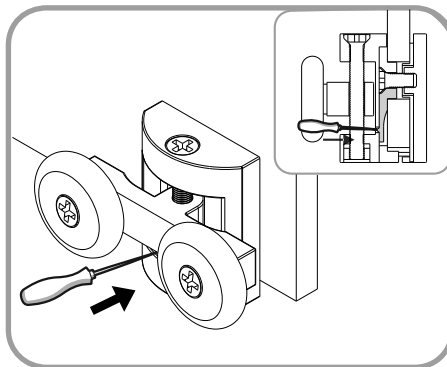
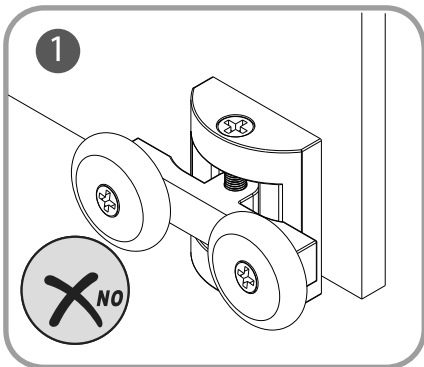
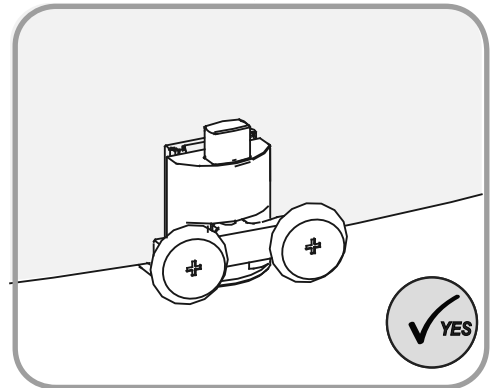
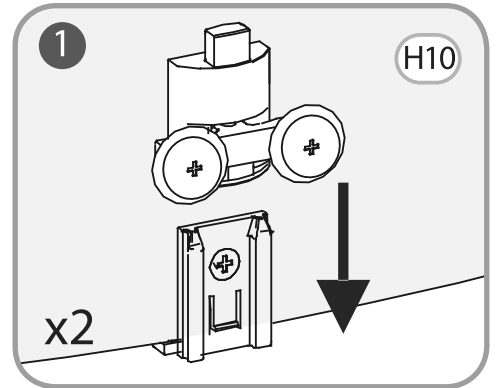
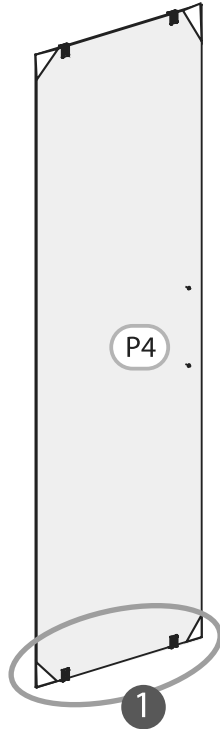
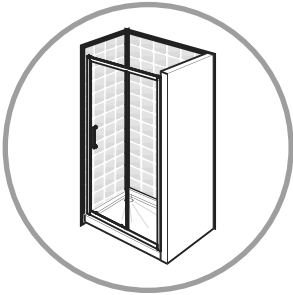

B

FR Montage

ES Montaje

PT Montagem

IT Montaggio

EL Συναρμολόγηση

PL Montaż

RU Сборка

UK Збірка

RO Montaj

EN Assembly

16

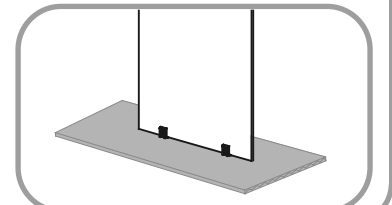
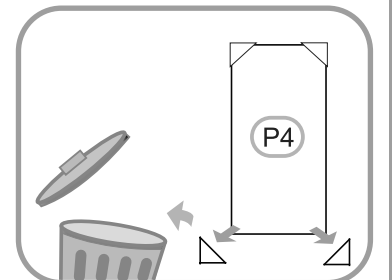
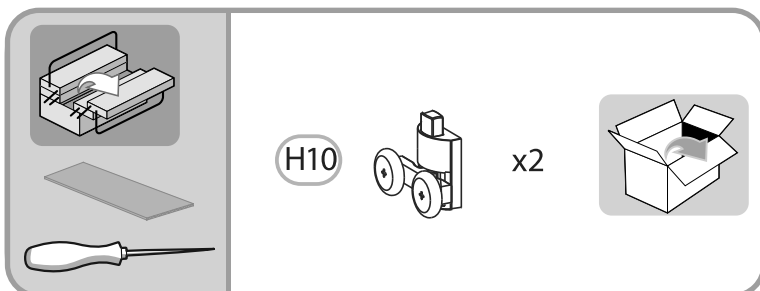
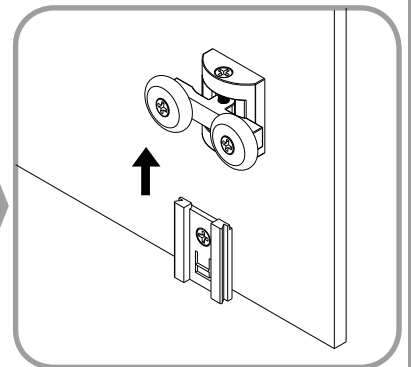
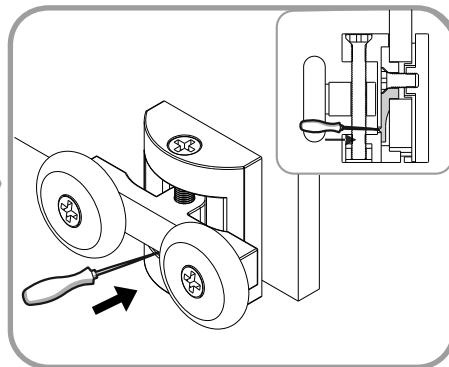
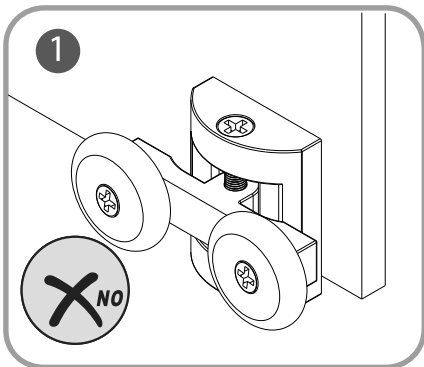
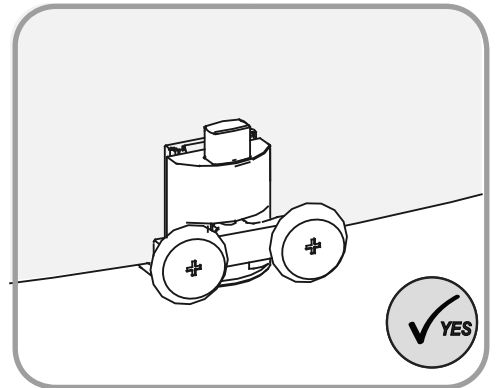
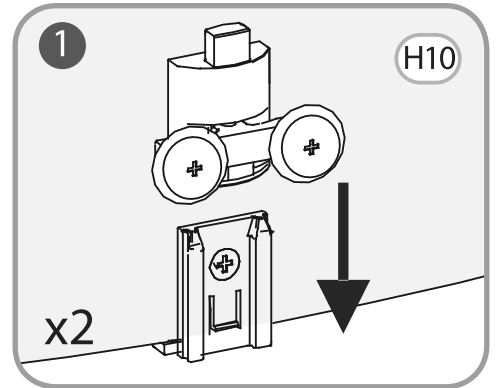
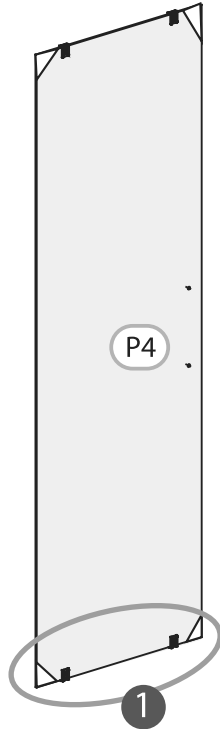
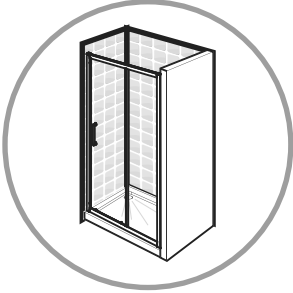

FR Montage

ES Montaje

PT Montagem

IT Montaggio

EL Συναρμολόγηση

PL Montaż

RU Сборка

UK Збірка

RO Montaj

EN Assembly

B

17

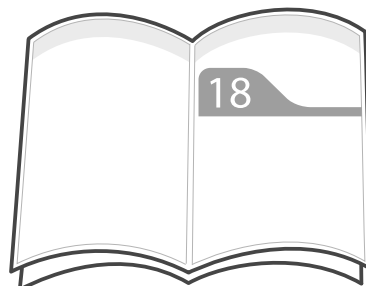
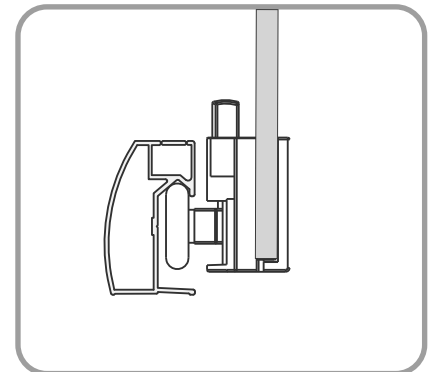
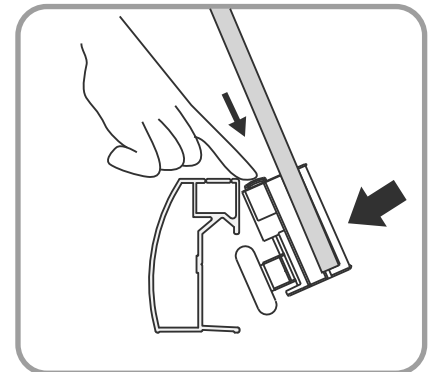
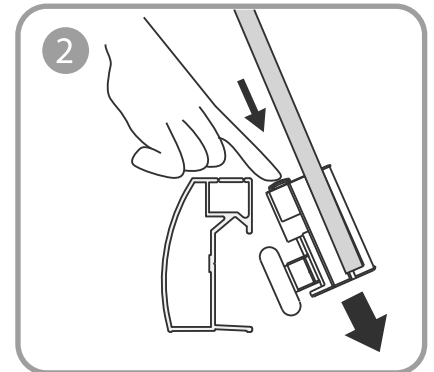
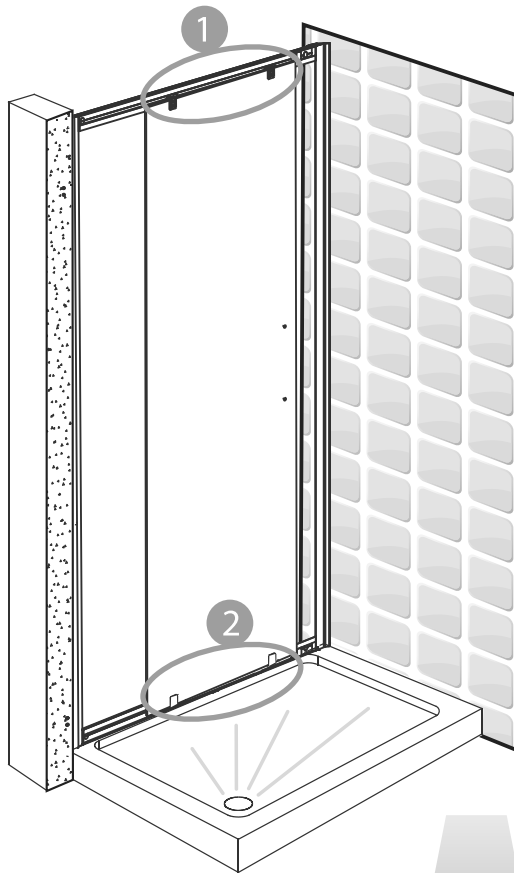
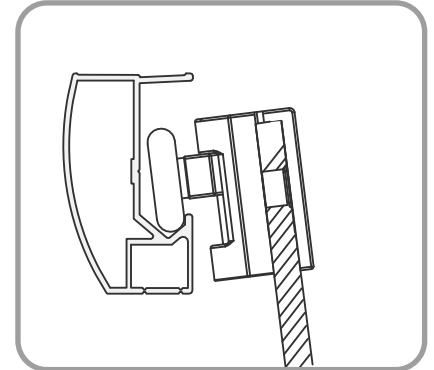
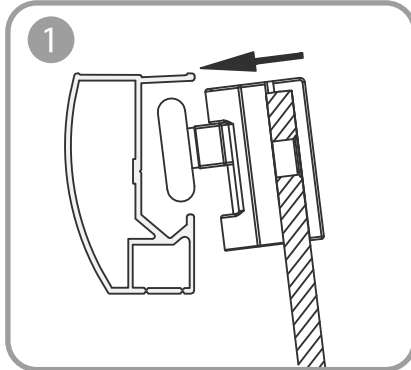
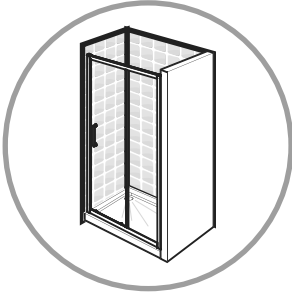

B

FR Montage

ES Montaje

PT Montagem

IT Montaggio

EL Συναρμολόγηση

PL Montaż

RU Сборка

UK Збірка

RO Montaj

EN Assembly

18

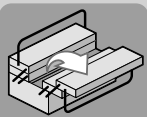
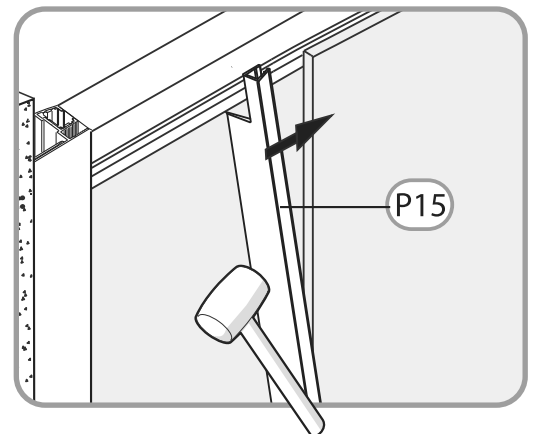
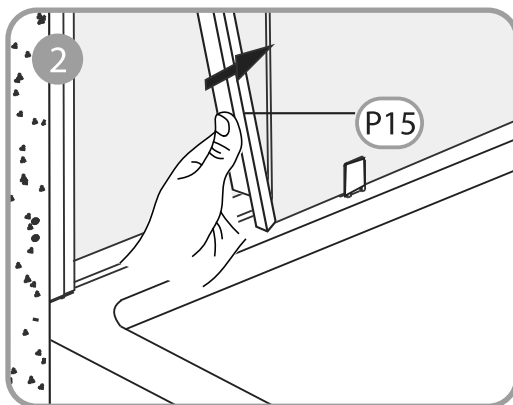
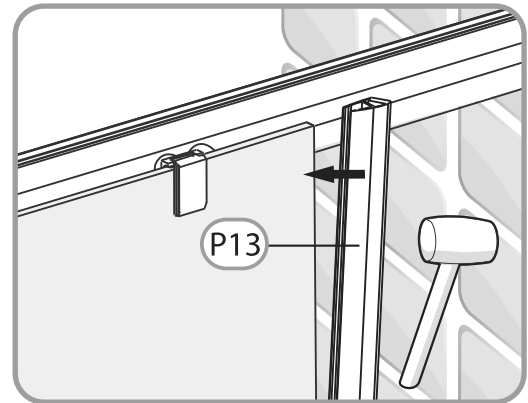
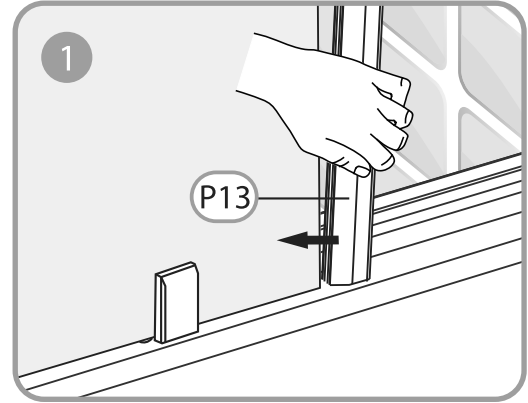
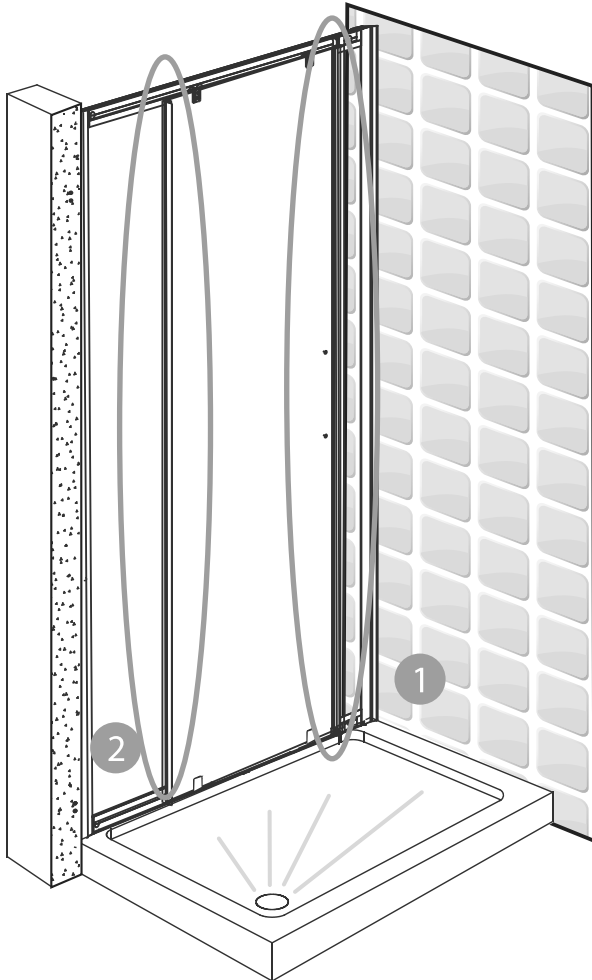

P15



x1

P13



x1

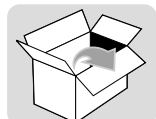

FR Montage

ES Montaje

PT Montagem

IT Montaggio

EL Συναρμολόγηση

PL Montaż

RU Сборка

UK Збірка

RO Montaj

EN Assembly

B

19

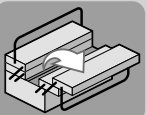
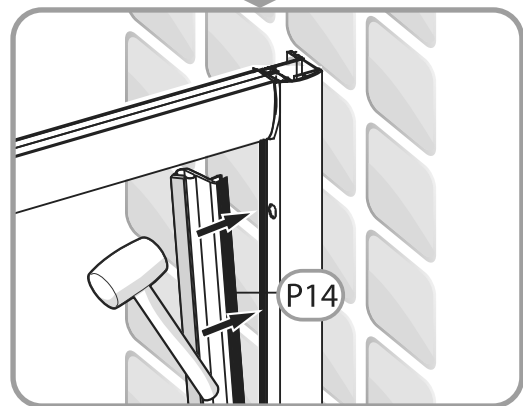
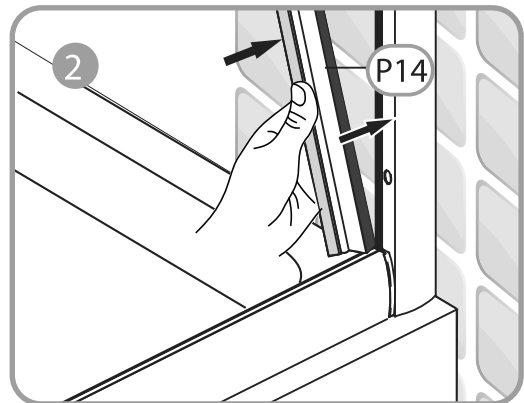
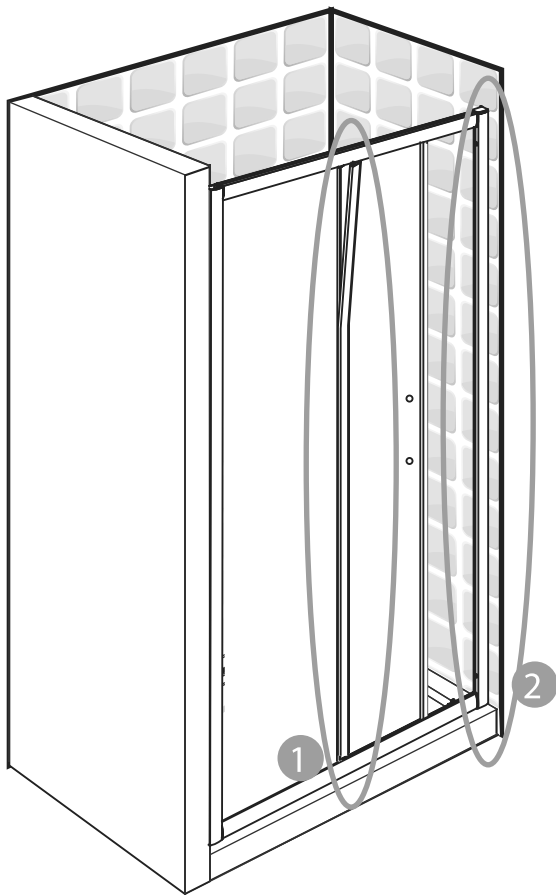
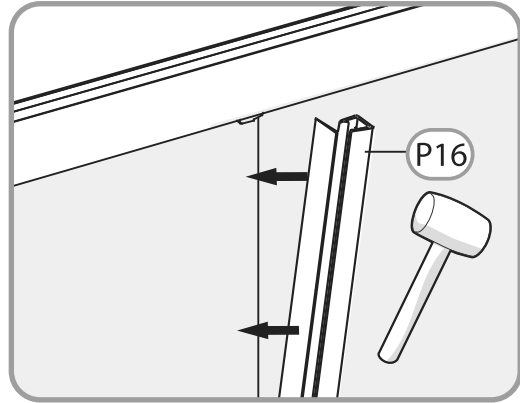
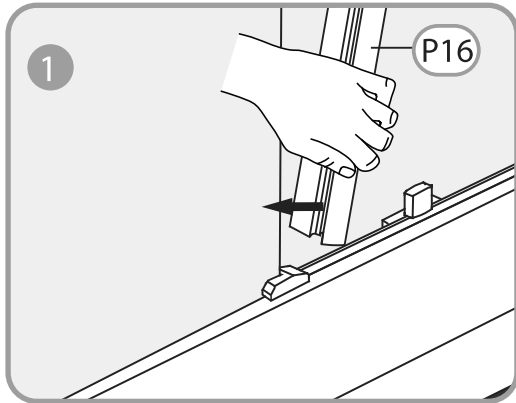

P16



x1

P14



x1

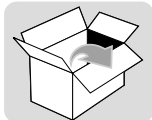

B

FR Montage

ES Montaje

PT Montagem

IT Montaggio

EL Συναρμολόγηση

PL Montaż

RU Сборка

UK Збірка

RO Montaj

EN Assembly

20

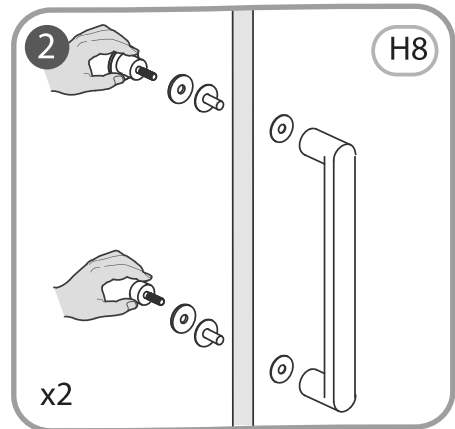
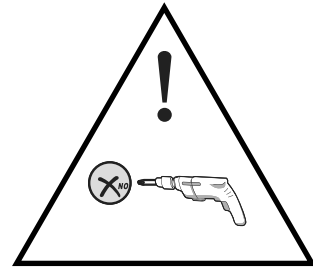
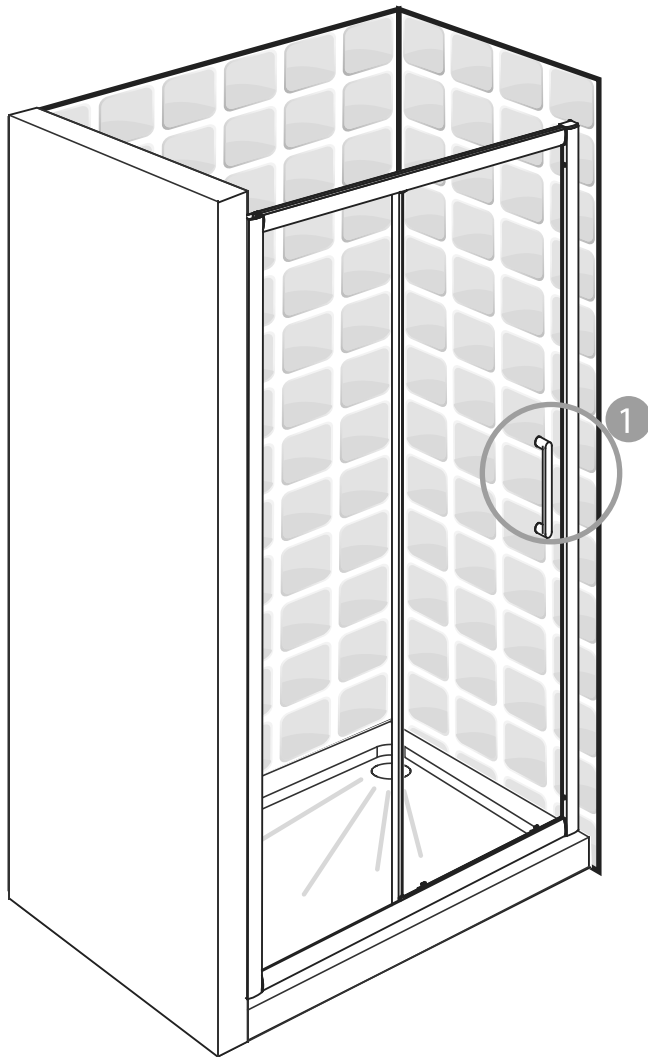

H8



x1

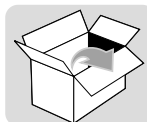

FR Montage

ES Montaje

PT Montagem

IT Montaggio

EL Συναρμολόγηση

PL Montaż

RU Сборка

UK Збірка

RO Montaj

EN Assembly

B

21

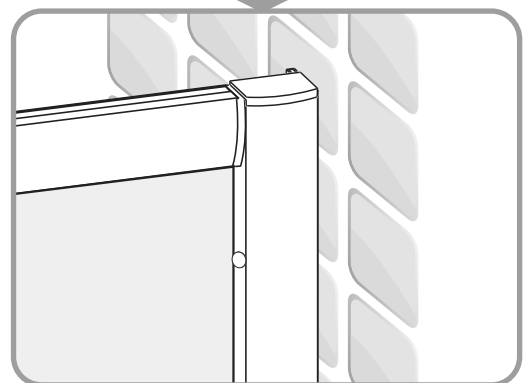
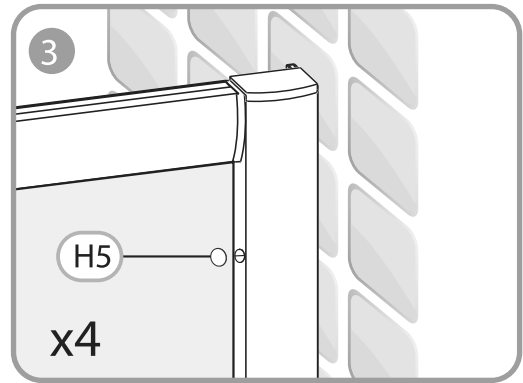
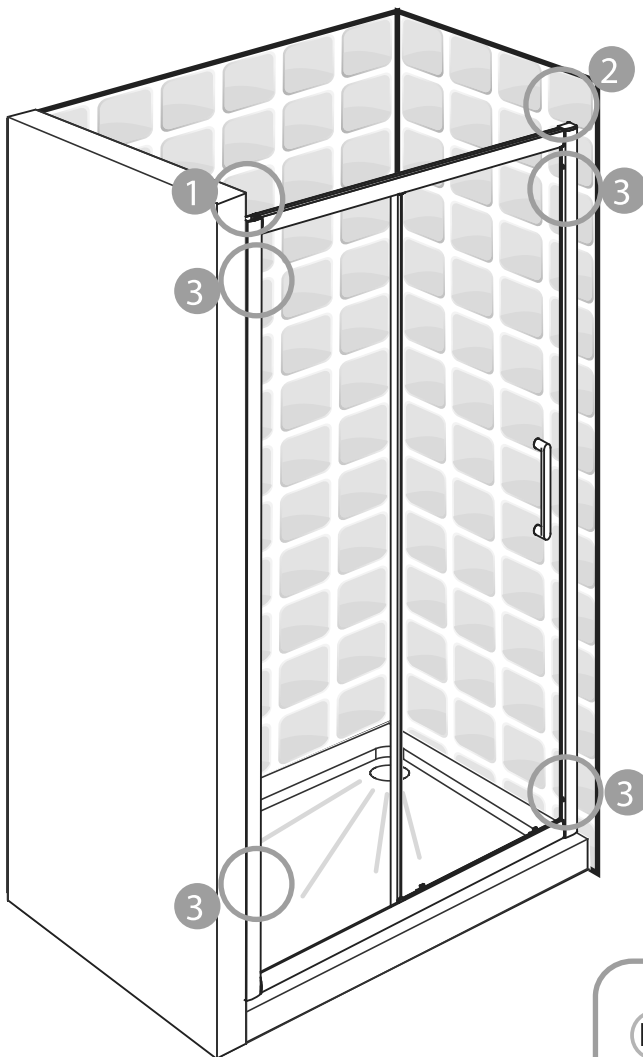
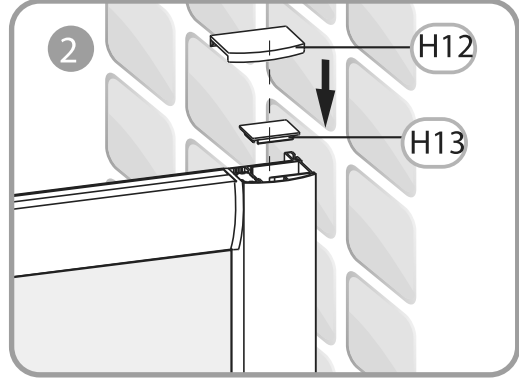
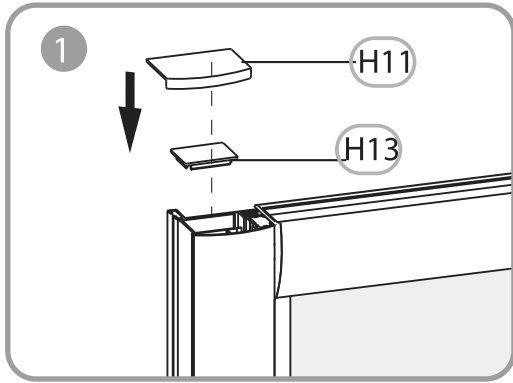

H11 x1

H12 x1

H13 x2

H5 x4

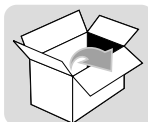

B

FR Montage

ES Montaje

PT Montagem

IT Montaggio

EL Συναρμολόγηση

PL Montaż

RU Сборка

UK Збірка

RO Montaj

EN Assembly

22

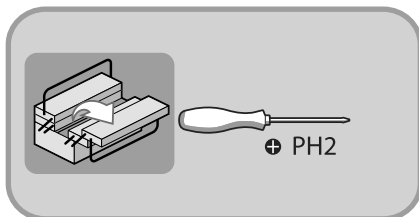
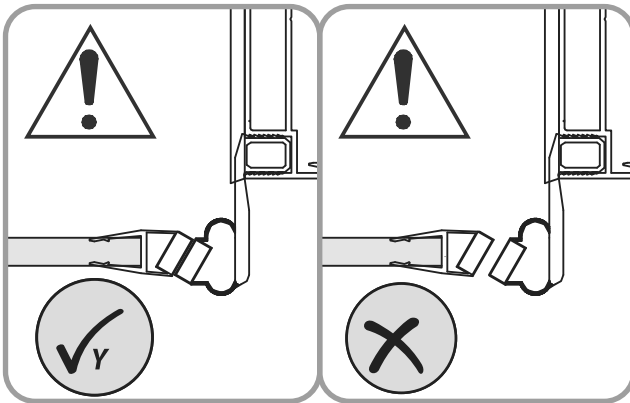
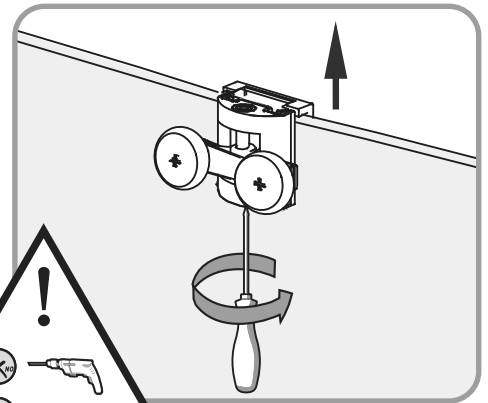
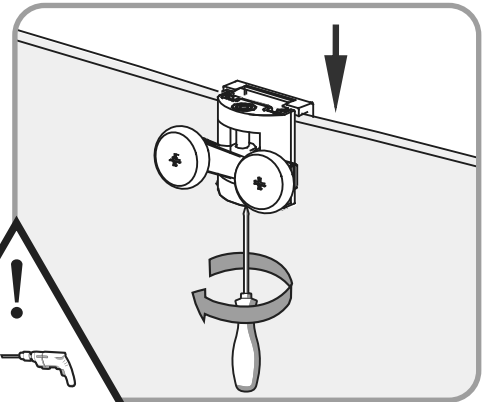
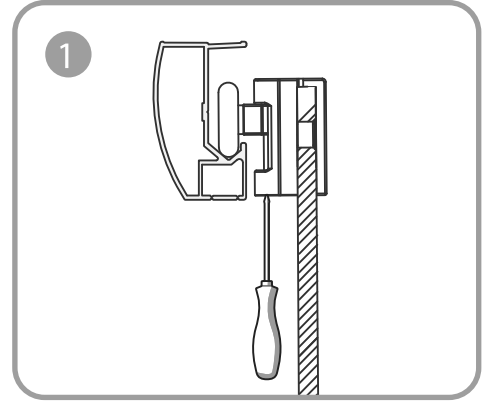
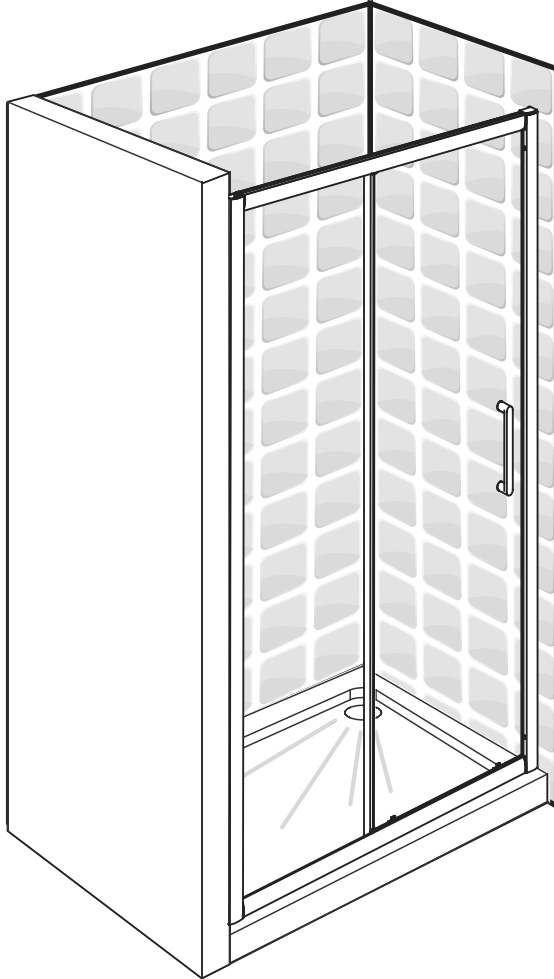

FR Montage

ES Montaje

PT Montagem

IT Montaggio

EL Συναρμολόγηση

PL Montaż

RU Сборка

UK Збірка

RO Montaj

EN Assembly

B

23

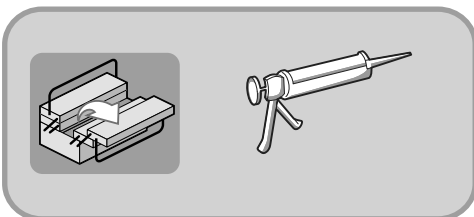
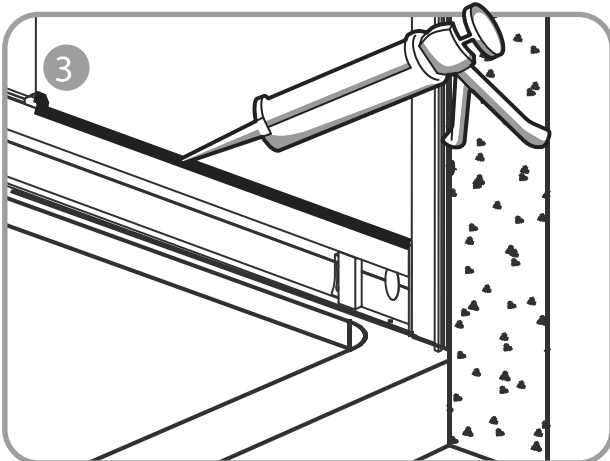
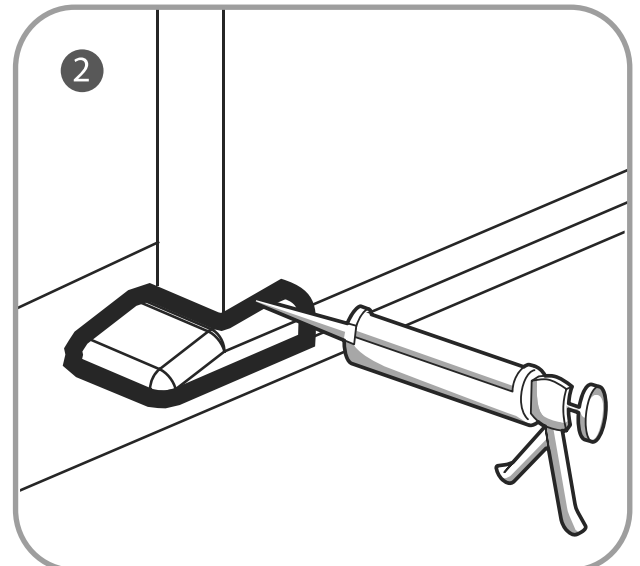
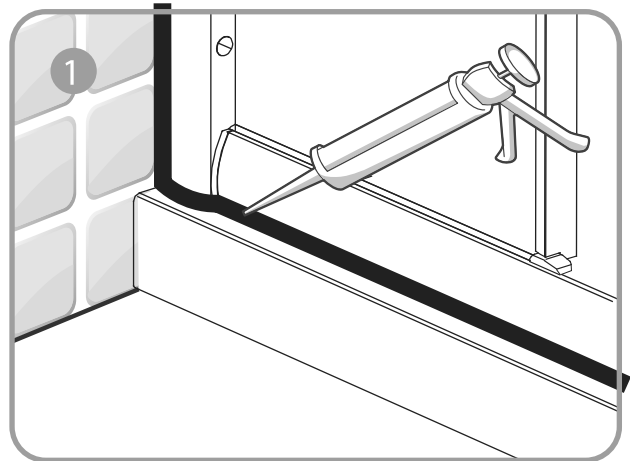
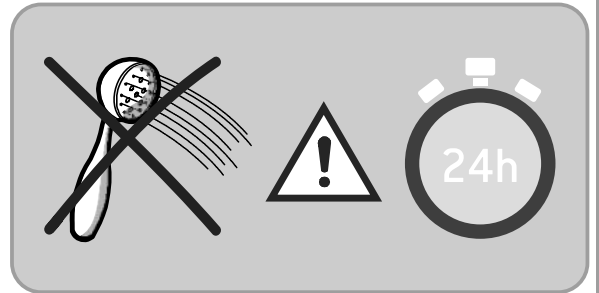
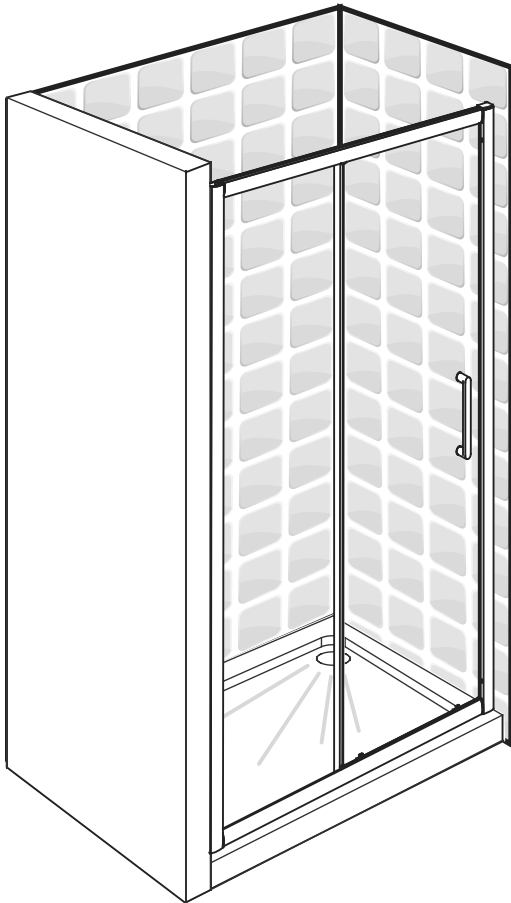

C

FR Entretien

ES Mantenimiento

PT Serviço

IT Manutenzione

EL Συντήρηση

PL Konserwacja

RU Уход

UK Догляд

RO Întreținere

EN Maintenance



Sans solvant / Sin disolvente / Sem solventes / Senza solventi / Χωρίς διαλυτικά / Bez rozpuszczalnika / Без растворителя /
Без розчинника / Fără solvent / Solvent-free

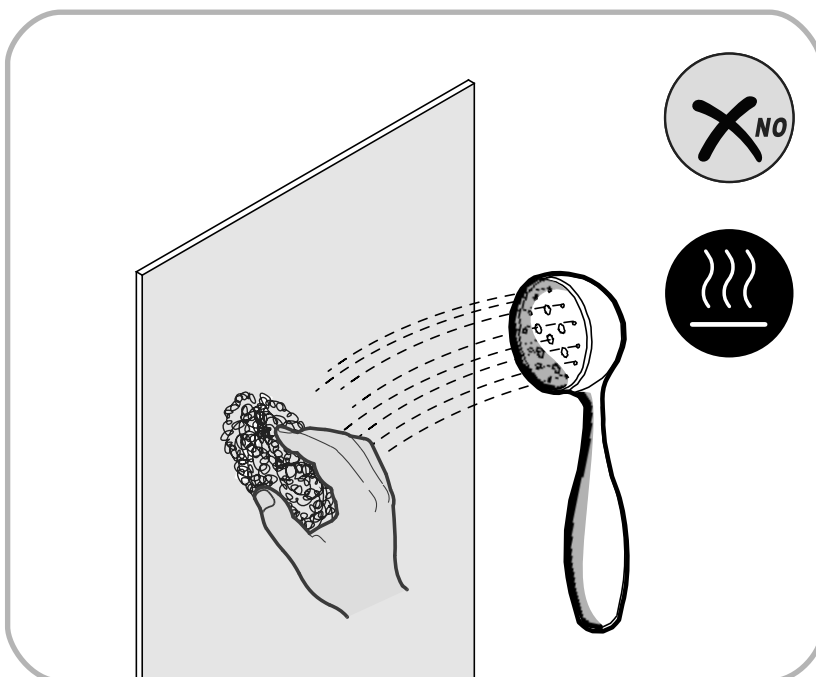
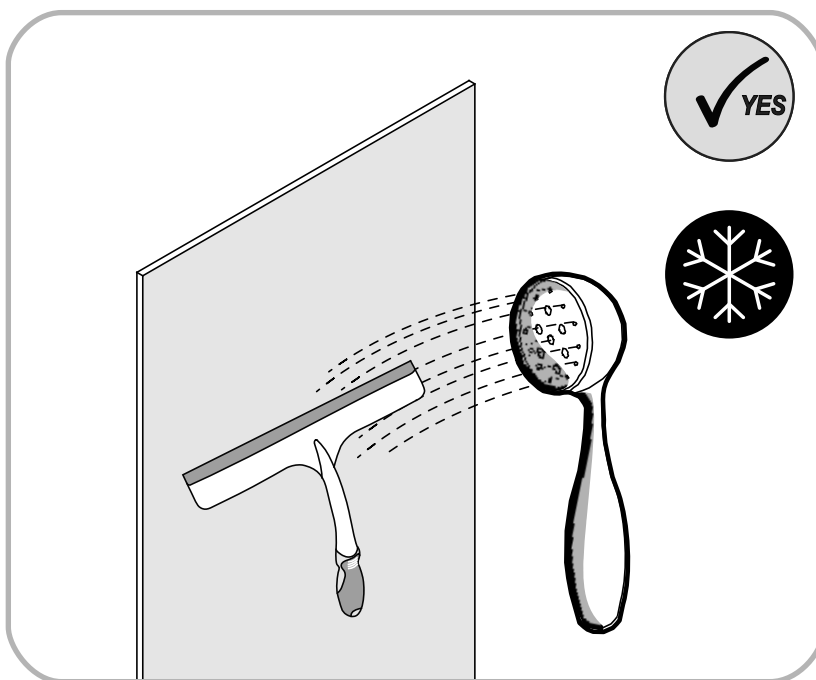

FR

CE

ADEO Services
135 Rue Sadi Carnot - CS 00001
59790 RONCHIN - France

16
EN 14428:2015

Code d'identification unique du produit type: **

usage prévu: hygiène personnelle
Nettoyable: Conforme

Résistance à l'impact/
Capacité de Fragmentation: Conforme

Durabilité: Conforme

DOP N° *

ES

CE

ADEO Services
135 Rue Sadi Carnot - CS 00001
59790 RONCHIN - France

16
EN 14428:2015

Código de identificación única del producto tipo: **

Uso previsto: higiene personal
Limpiable: Conforme

Resistencia al impacto/
Capacidad de fragmentación: Conforme

Durabilidad: Conforme

DOP N° *

PT

CE

ADEO Services
135 Rue Sadi Carnot - CS 00001
59790 RONCHIN - France

16
EN 14428:2015

Código de identificação único do produto-tipo: **

Utilização prevista: higiene pessoal
Limpeza: Conforme

Resistência ao impacto/
Capacidade de fragmentação: Conforme

Durabilidade: Conforme

DOP N° *

IT

CE

ADEO Services
135 Rue Sadi Carnot - CS 00001
59790 RONCHIN - France

16
EN 14428:2015

Codice di identificazione unico del prodotto-tipo: **

Uso previsto: igiene personale
Pulibile: Conforme

Resistenza agli urti/
Capacità di Frammentazione: Conforme

Durata: Conforme

DOP N° *

EL

CE

ADEO Services
135 Rue Sadi Carnot - CS 00001
59790 RONCHIN - France

16
EN 14428:2015

Μοναδικός κωδικός ταυτοποίησης του τύπου του προϊόντος: **

προβλεπόμενη χρήση: προσωπική υγιεινή
«υνατότητα καθαρισμού: Σύμφωνος με

Αντοχή σε κρούση/
Ικανότητα κατάτμησης: Σύμφωνος με

«άρκεια: Σύμφωνος με

DOP N° *

PL

CE

ADEO Services
135 Rue Sadi Carnot - CS 00001
59790 RONCHIN - France

16
EN 14428:2015

Niepowtarzalny kod identyfikacyjny typu wyrobu: **

przeznaczenie: higiena osobista
Możliwość czyszczenia: Zgodny

Odporność na uderzenia/
Rozkruszalność: Zgodny

Trwałość: Zgodny

DOP N° *

RU

CE

ADEO Services
135 Rue Sadi Carnot - CS 00001
59790 RONCHIN - France

16
EN 14428:2015

Уникальный идентификационный код типа изделия: **

Назначение: личная гигиена
Легкость очистки: Соответствие

Ударопрочность/
Мощность распыления: Соответствие

Долговечность: Соответствие

DOP N° *

UK

CE

ADEO Services
135 Rue Sadi Carnot - CS 00001
59790 RONCHIN - France

16
EN 14428:2015

Унікальний ідентифікаційний код виду продукції: **

призначення: особиста гігієна
Легкість очищення: Відповідність

Ударостійкість/
Потужність розпилення: Відповідність

Довговічність: Відповідність

DOP N° *

RO

CE

ADEO Services
135 Rue Sadi Carnot - CS 00001
59790 RONCHIN - France

16
EN 14428:2015

Cod unic de identificare a tipului de produs: **

destinație: igienă personală
Posibilitatea de cuștare: Conform

Rezistență la impact/
Capacitate de fragmentare: Conform

Durabilitate: Conform

DOP N° *

EN

CE

ADEO Services
135 Rue Sadi Carnot - CS 00001
59790 RONCHIN - France

16
EN 14428:2015

Unique identification code of the product-type: **

Intended use: personal hygiene
cleanability: Pass

Impact resistance/ shatter properties: Pass

Durability: Pass

DOP N° *

**

FR Reportez-vous à l'annexe.

ES Consulte el apéndice.

PT Consulte o anexo.

IT Consultare l'appendice.

EL Ανατρέξτε στο Παράρτημα.

PL Patrz załącznik.

RU См. приложение.

UK Читайте додаток.

RO Consultați anexa.

EN Refer to appendix.

ADEO Services
135 Rue Sadi Carnot
CS 00001
59790 RONCHIN - France

ТОВ «Леруа Мерлен Україна»,
вул. Полярна 17а, м. Київ
04201, Україна

ООО ЛЕРУА МЕРЛЕН ВОСТОК,
141031, Московская область,
Мытищинский район, г. Мытищи,
Осташковское шоссе, д.1, РОССИЯ

* Garantie 3 ans / Garantía 3 años / Garantia 3 anos / Garanzia 3 anni
Εγγύηση 3 ετών / Gwarancja 3 lat / 3 летняя / 3-річна гарантія
3 ani garanție / Guarantee 3 years

Made In P. R.C. 2016